

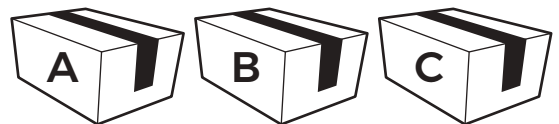

# ASSEMBLY INSTRUCTIONS



DESIGN BY HOMSEE  
VERSION: HS650006US-CJC-001

 This product comes in 3 packages





---

One of the unique features of Homsee furniture is its versatility. Designed with the idea of customization in mind, our products can be easily linked together to create seamless, personalized setups that fit your specific needs.

For instance, if you purchase a couple of our shelves, you can effortlessly combine them to form a larger, unified structure. This modular approach allows you to expand, rearrange, and adapt your furniture as your space and style evolve. Whether you're looking to create a vast shelving system, or a continuous storage solution, the possibilities are endless.

At Homsee, we empower you to create a space that is truly yours—one that grows with you, all while maintaining a sleek, cohesive look.



---

Una de las características distintivas del mobiliario Homsee es su versatilidad. Diseñados pensando en la personalización, nuestros productos pueden conectarse fácilmente entre sí para crear configuraciones continuas y personalizadas que se ajusten a tus necesidades específicas.

Por ejemplo, si compras un par de nuestras estanterías, puedes combinarlas sin esfuerzo para formar una estructura más grande y unificada. Este enfoque modular te permite ampliar, reorganizar y adaptar tus muebles a medida que evolucionan tu espacio y tu estilo. Ya sea que busques crear un amplio sistema de estanterías o una solución de almacenamiento continua, las posibilidades son infinitas.

En Homsee, te ayudamos a crear un espacio verdaderamente tuyo—uno que crece contigo, manteniendo a la vez un aspecto elegante y coherente.



## IMPORTANT INFORMATION!

Please read the entire manual before starting to assembling or using this product. Follow the manual thoroughly and keep it for further reference.

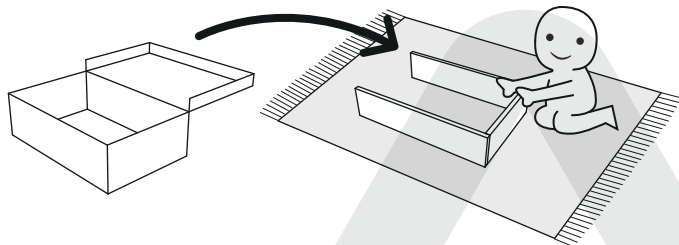

## AVOID SCRATCHES!

In order to avoid scratching the furniture should be assembled on a soft layer—could be a rug.

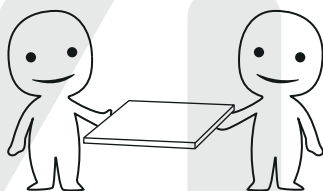

## IMPROVE ASSEMBLY EFFICIENCY !

Try to find a partner to install with you, which can speed up the installation efficiency and shorten the time.

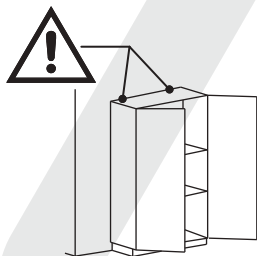

## ANTI-TOPPLE WARNING !

Overturned furniture can cause serious or fatal crush injuries. To prevent tipping, be sure to use a wall-anchoring attachment. If one is not included with this product, please purchase a suitable attachment that fits your wall. If unsure, seek professional advice. Please read and follow all instructions carefully.

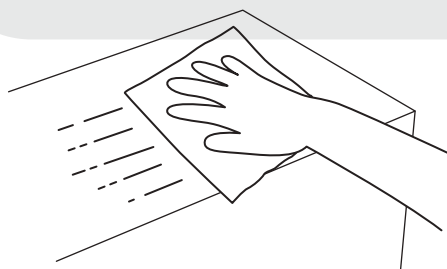

## MAINTENANCE AND CLEANING !

For regular maintenance and cleaning, use a rag dipped in neutral detergent to wipe the frame thoroughly, and then dry it with a clean rag. For glass surfaces, wipe with a rag dampened with water or glass cleaner, and then dry with a clean, dry cloth.

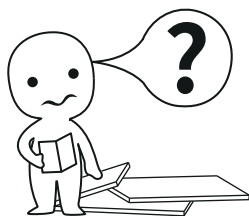

## ¡INFORMACIÓN IMPORTANTE!

Por favor, lee todo el manual antes de comenzar a ensamblar o usar este producto. Sigue las instrucciones detenidamente y consérvalo para futuras consultas.

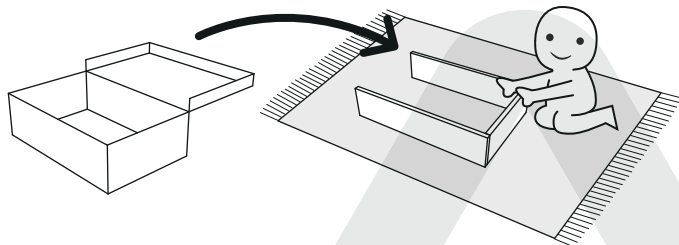

## ¡EVITA LOS RAYONES!

Para evitar que el mueble se raye, debe ensamblarse sobre una superficie suave, como una alfombra.

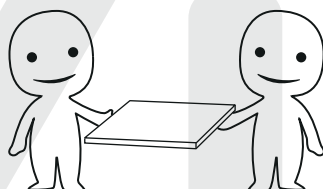

## ¡MEJORA LA EFICIENCIA!

Intenta encontrar a alguien que te ayude con la instalación; trabajar en pareja puede aumentar la eficiencia y reducir el tiempo de montaje.

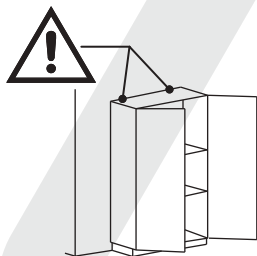

## ¡ADVERTENCIA ANTIVUELCO!

El mobiliario volcado puede causar lesiones graves o incluso mortales por aplastamiento. Para evitar que se vuelque, asegúrate de utilizar el sistema de anclaje a la pared. Si este producto no lo incluye, adquiere un anclaje compatible con tu pared. Si no estás seguro de cuál usar, busca asesoramiento profesional. Lee y sigue cuidadosamente cada paso de las instrucciones.

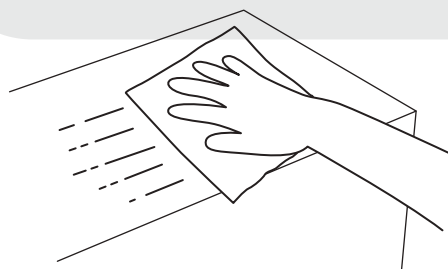

## ¡MANTENIMIENTO Y LIMPIEZA!

Para el mantenimiento y la limpieza regulares del producto, limpia el marco con un paño humedecido en un detergente neutro y luego sécalo con un paño limpio. Para los materiales de vidrio, límpialos con un paño humedecido en limpiador de vidrios con agua y luego sécalos con un paño seco.



The following are common installation steps. Correct operation is required to avoid product damage.

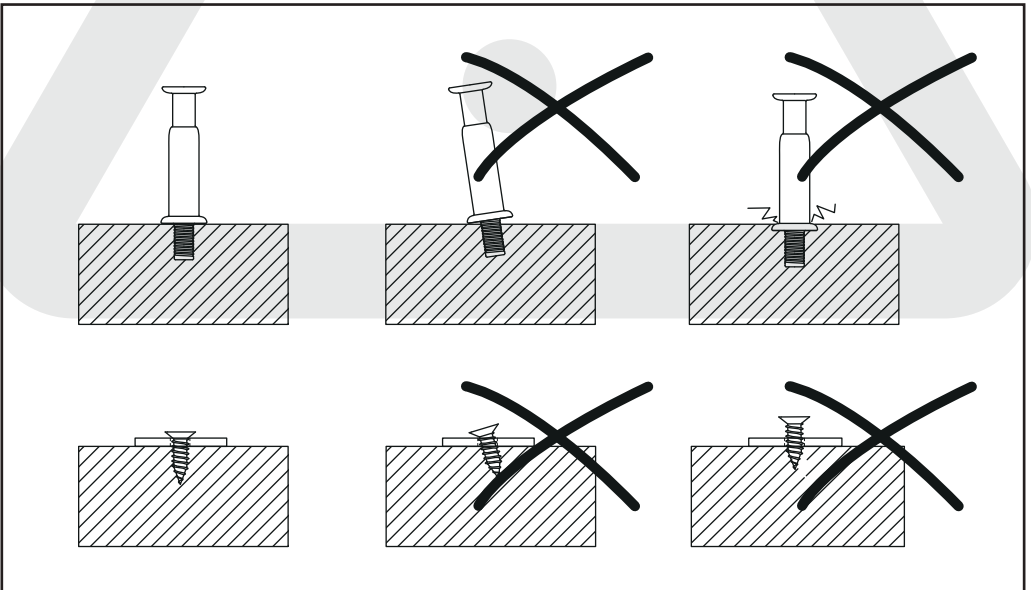
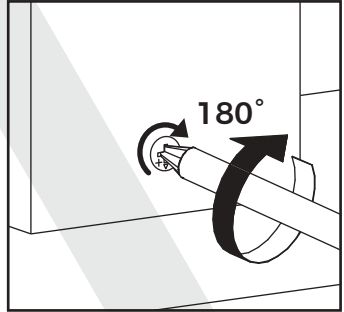
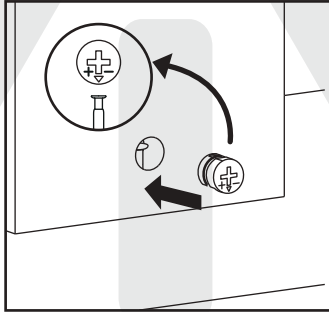
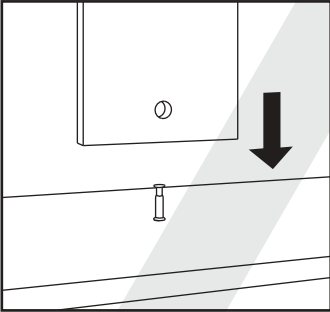
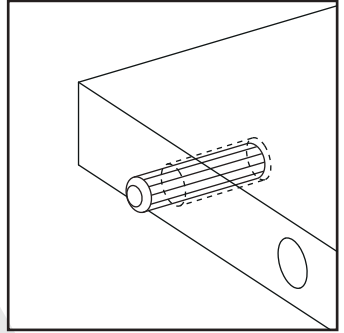
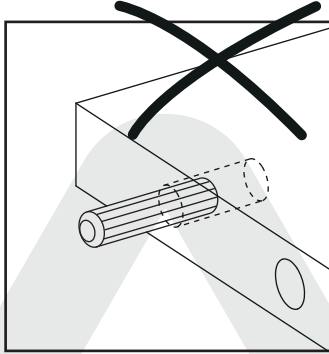
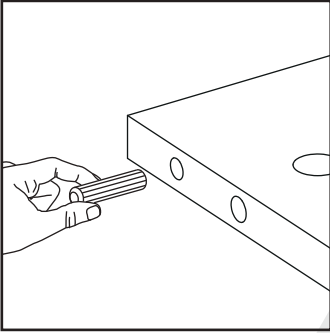



Los siguientes pasos de instalación son bastante comunes y requieren una operación correcta durante el proceso de montaje. El uso incorrecto puede dañar el mueble.

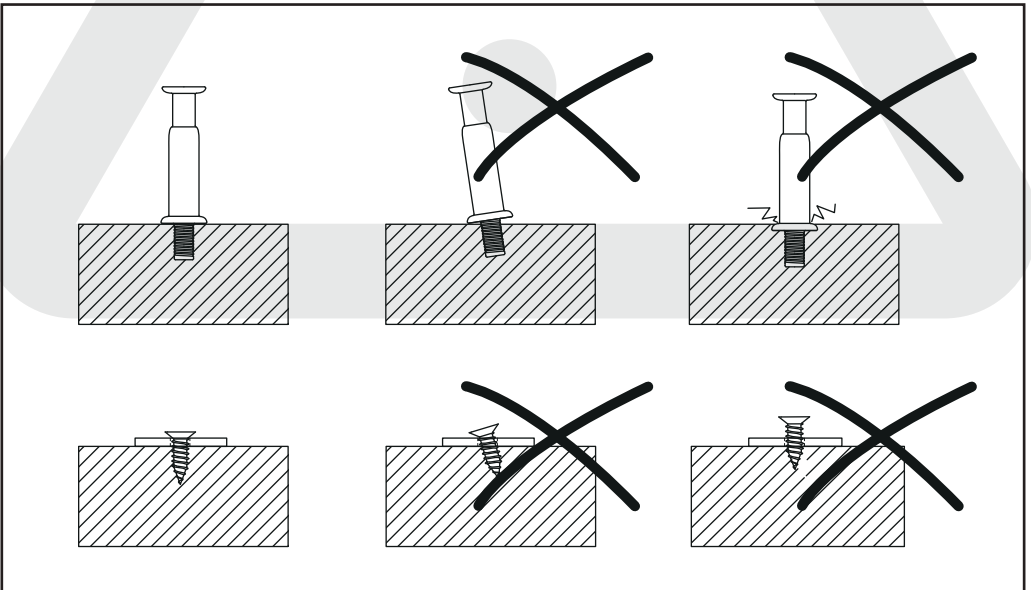
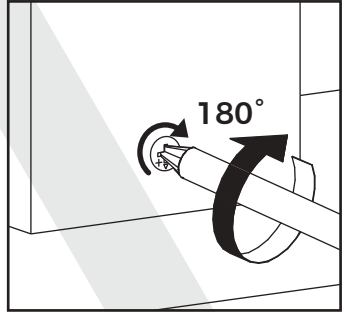
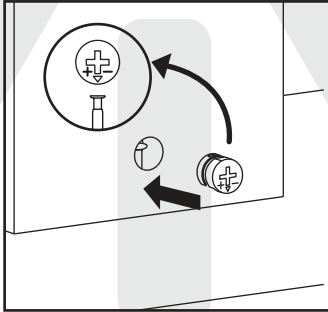
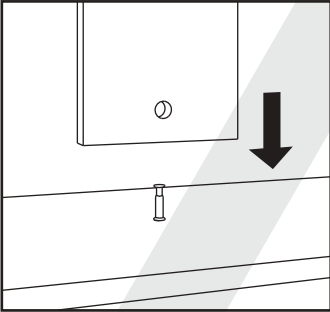
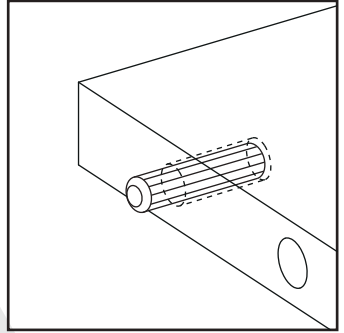
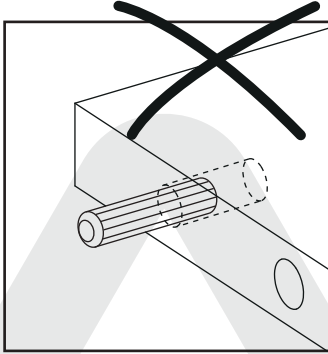
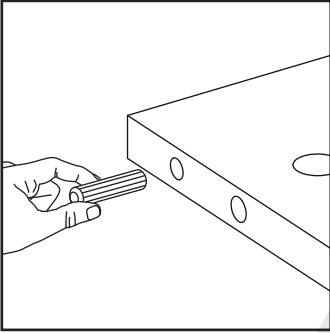



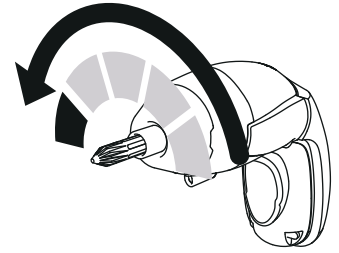
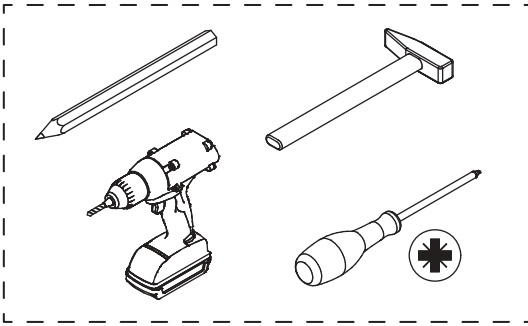









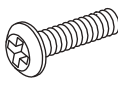

**Please prepare the following tools**

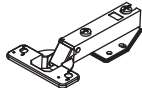

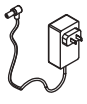
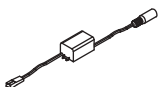
If you choose to use power tools, set them to a low-power setting. Use caution—power tools may crack or damage the furniture and can also harm the hardware.

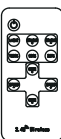

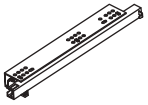
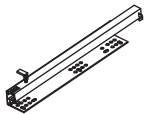
Some accessories have similar shapes, please distinguish them according to their numbers and sizes during installation.

<p>A x 105</p>  <p>∅6 x 40 mm</p>	<p>B x 105</p>  <p>∅15 x 12 mm</p>	<p>C x 8</p>  <p>∅6 x 30 mm</p>	<p>D x 12</p>  <p>∅4 x 35 mm</p>	<p>E x 82</p>  <p>∅3.5 x 14 mm</p>
<p>F x 14</p>  <p>∅4 x 20 mm</p>	<p>G x 7</p>  <p>∅13 x 128 mm</p>	<p>H x 10</p>  <p>∅35 mm</p>	<p>J x 2</p>  <p>∅8 x 38 mm</p>	<p>K x 2</p>  <p>72 x 15 mm</p>
<p>L x 1</p>  <p>Junction Box</p>	<p>L x 1</p>  <p>Pulg</p>	<p>L x 1</p>  <p>Switch</p>	<p>L x 12</p>  <p>LEDstrip</p>	<p>L x 1</p> 
<p>M x 30</p> 	<p>DL x 3</p>  <p>L = 14 inch</p>	<p>DR x 3</p>  <p>L = 14 inch</p>	<p>x 30</p> 	

**Por favor, prepara las siguientes herramientas**

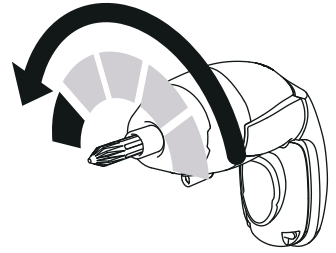
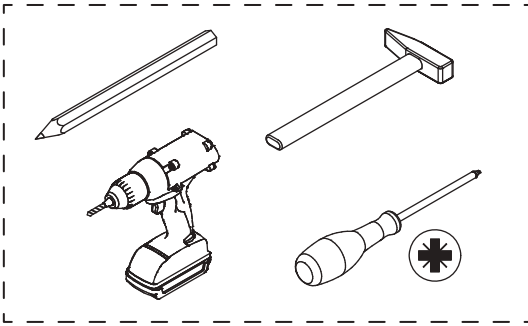

Si decides utilizar herramientas eléctricas, ajústalas a una velocidad baja. ¡Ten cuidado! Las herramientas eléctricas pueden causar grietas o daños en el mueble, y también pueden dañar los herrajes.



Algunos accesorios tienen la misma forma; por favor, distíngalos según sus números y tamaños durante la instalación.

<p>A x 105</p> <p>Ø6 x 40 mm</p>	<p>B x 105</p> <p>Ø15 x 12 mm</p>	<p>C x 8</p> <p>Ø6 x 30 mm</p>	<p>D x 12</p> <p>Ø4 x 35 mm</p>	<p>E x 82</p> <p>Ø3.5 x 14 mm</p>
<p>F x 14</p> <p>Ø4 x 20 mm</p>	<p>G x 7</p> <p>Ø13 x 128 mm</p>	<p>H x 10</p> <p>Ø35 mm</p>	<p>J x 2</p> <p>Ø8 x 38 mm</p>	<p>K x 2</p> <p>72 x 15 mm</p>
<p>L x 1</p> <p>Junction Box</p>	<p>L x 1</p> <p>Pulg</p>	<p>L x 1</p> <p>Switch</p>	<p>L x 12</p> <p>LEDstrip</p>	<p>DL x 3</p> <p>L = 14 inch</p>
<p>DR x 3</p> <p>L = 14 inch</p>	<p>x 30</p>			

# Parts List

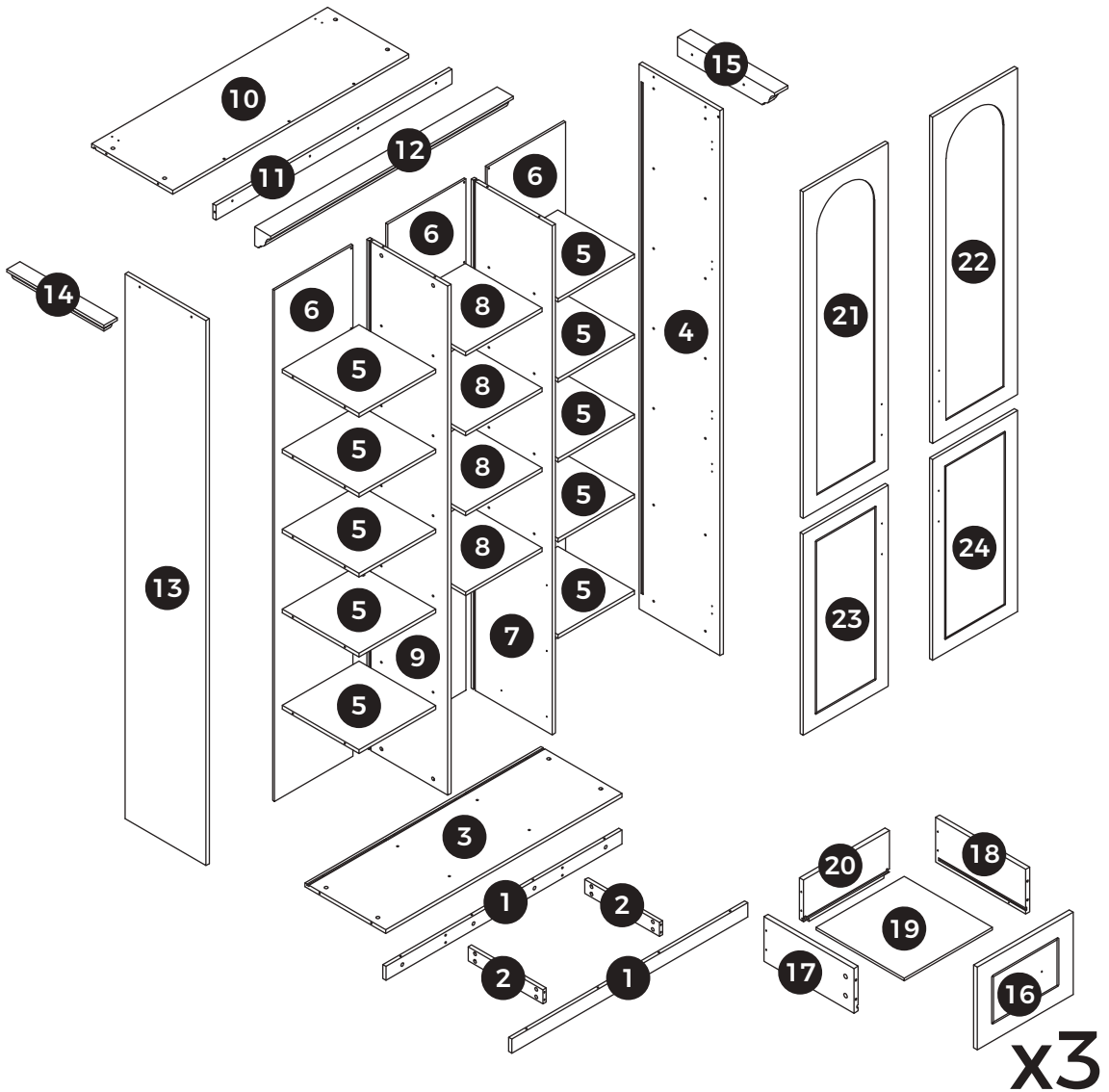

**WARNING**

Children have died from furniture tipover. To reduce the risk of furniture tipover:

- ALWAYS install Anti-tip device provided
- NEVER put a TV on this product.
- NEVER allow children to stand, climb or hang on drawers, doors, or shelves.
- NEVER open more than one drawer at a time.
- Place heaviest items in the lowest drawers.

This is a permanent label. Do not remove!



90 MINUTES



2 ADULTS



INTERMEDIATE

The parts listed above are required for proper assembly. If there are any issues. Contact us: [customerservice@homsee.com](mailto:customerservice@homsee.com)

# Lista de Piezas

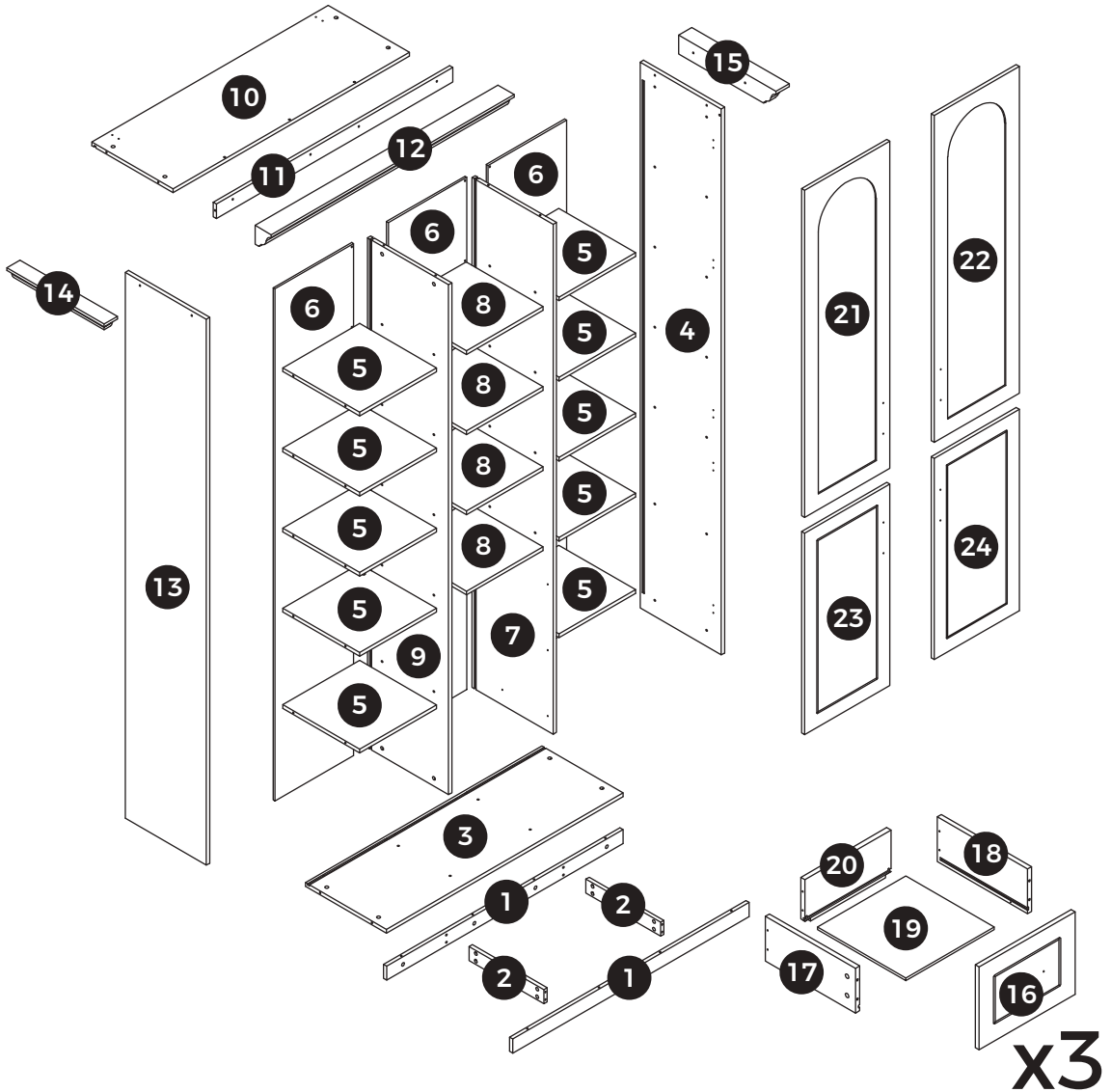

**⚠ ADVERTENCIA**

**Los niños han muerto por el vuelco de muebles. Para reducir el riesgo de que el mueble se vuelque:**

- SIEMPRE instala el dispositivo antivuelco incluido.
- NUNCA coloques un televisor sobre este producto.
- NUNCA permitas que los niños se suban, trepen o cuelguen de los cajones, puertas o estantes.
- NUNCA abras más de un cajón a la vez.
- Coloca los objetos más pesados en los cajones inferiores.

**Esta es una etiqueta permanente. ¡No la retires!**



90 MINUTOS



2 ADULTOS



INTERMEDIO

Las piezas enumeradas arriba son necesarias para un montaje correcto. Si tienes algún problema, contáctanos en: [customerservice@homsee.com](mailto:customerservice@homsee.com)



Cut out this page for easy viewing during subsequent installation.

Recorte esta página para poder consultarla fácilmente durante la instalación posterior.

# Parts List

## Lista de Piezas



BOX 1/3  
CAJA 1/3

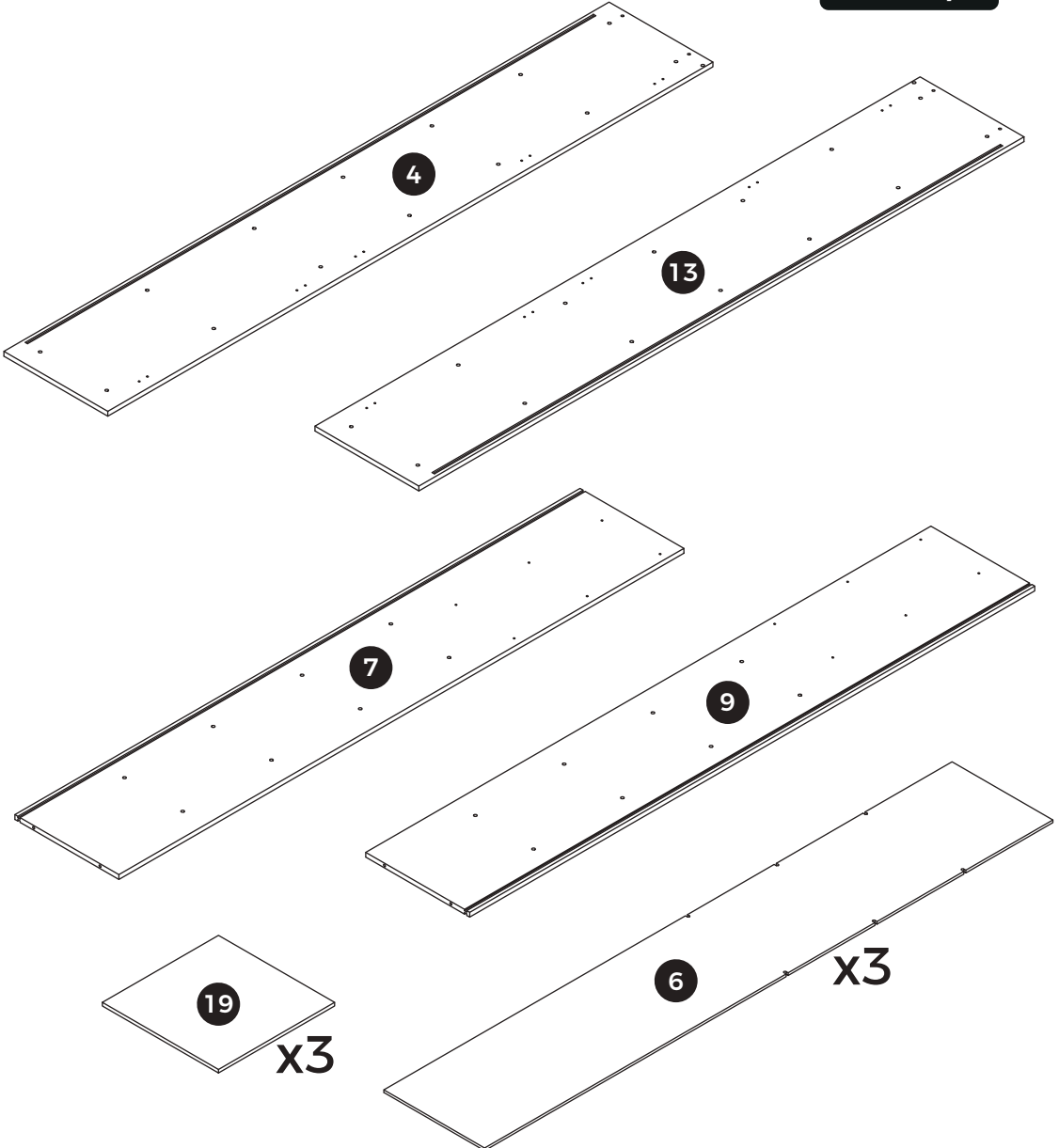

# Parts List

## Lista de Piezas

Cut out this page for easy viewing during subsequent installation.

Recorte esta página para poder consultarla fácilmente durante la instalación posterior.

BOX 2/3  
CAJA 2/3

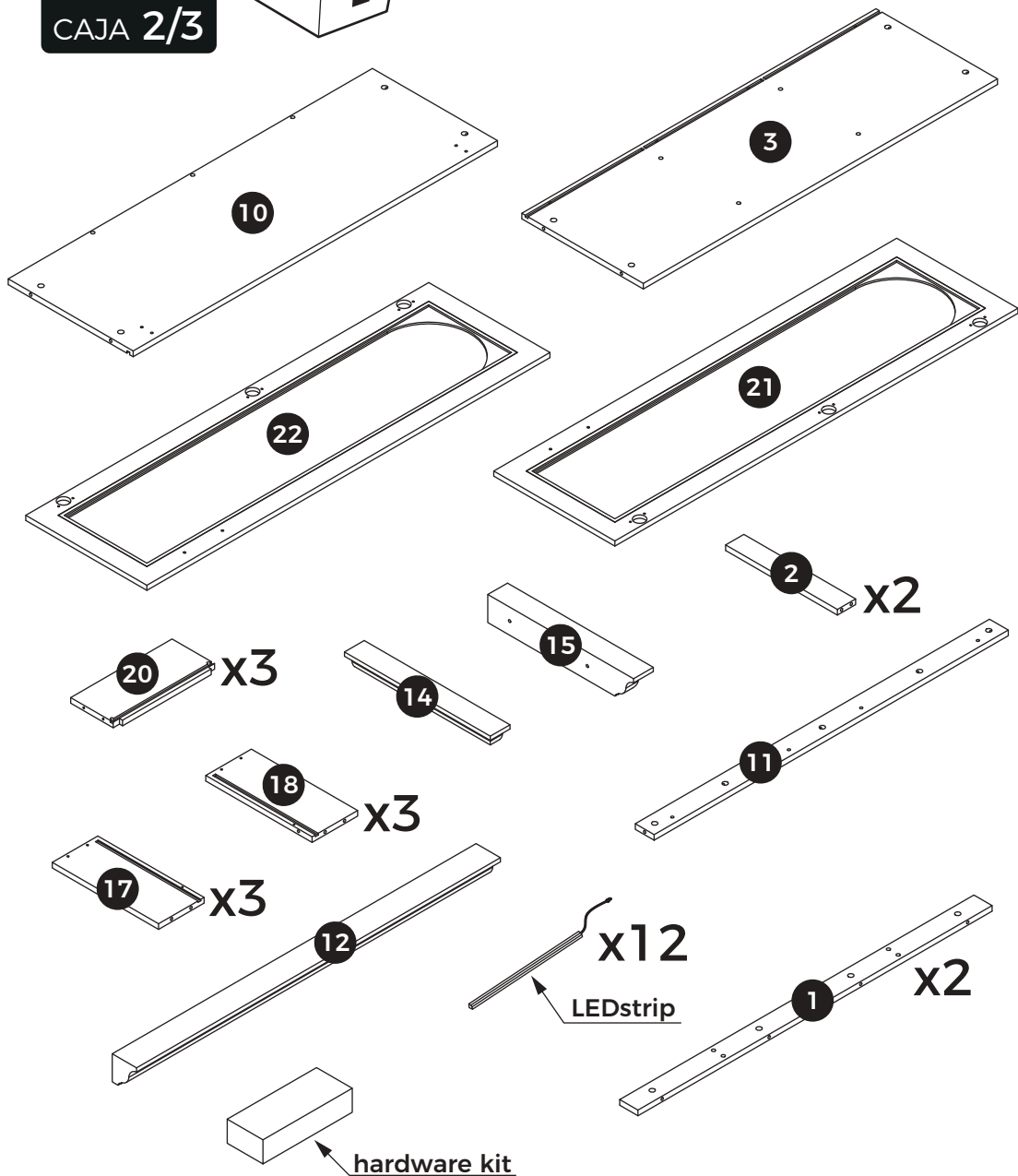
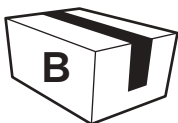



Cut out this page for easy viewing during subsequent installation.

Recorte esta página para poder consultarla fácilmente durante la instalación posterior.

# Parts List

## Lista de Piezas

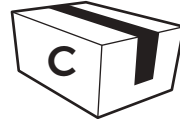

BOX **3/3**  
CAJA **3/3**

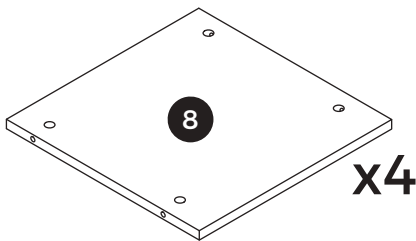
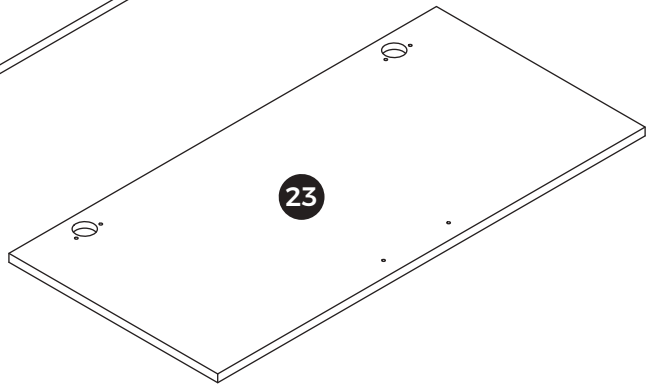
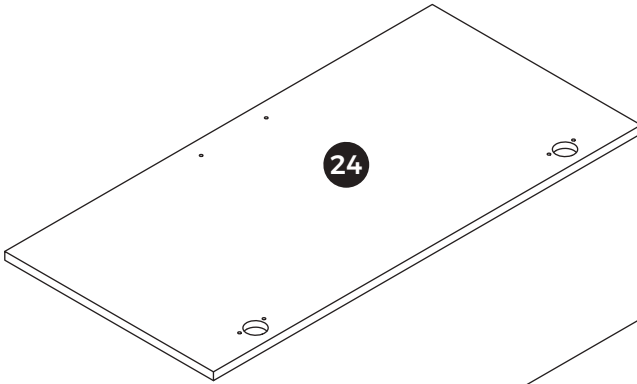

x4

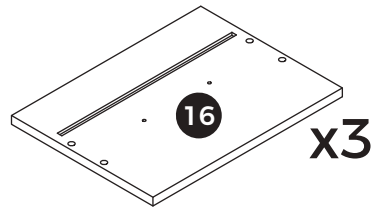

x3

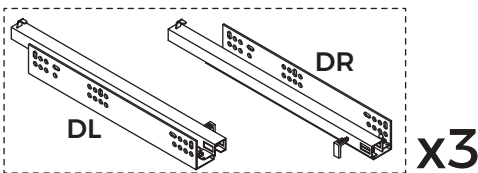

x3

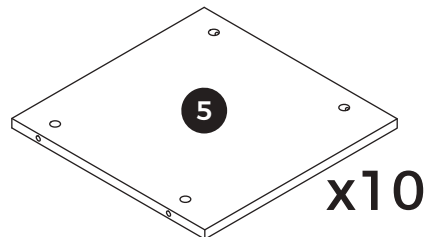

x10



# 01

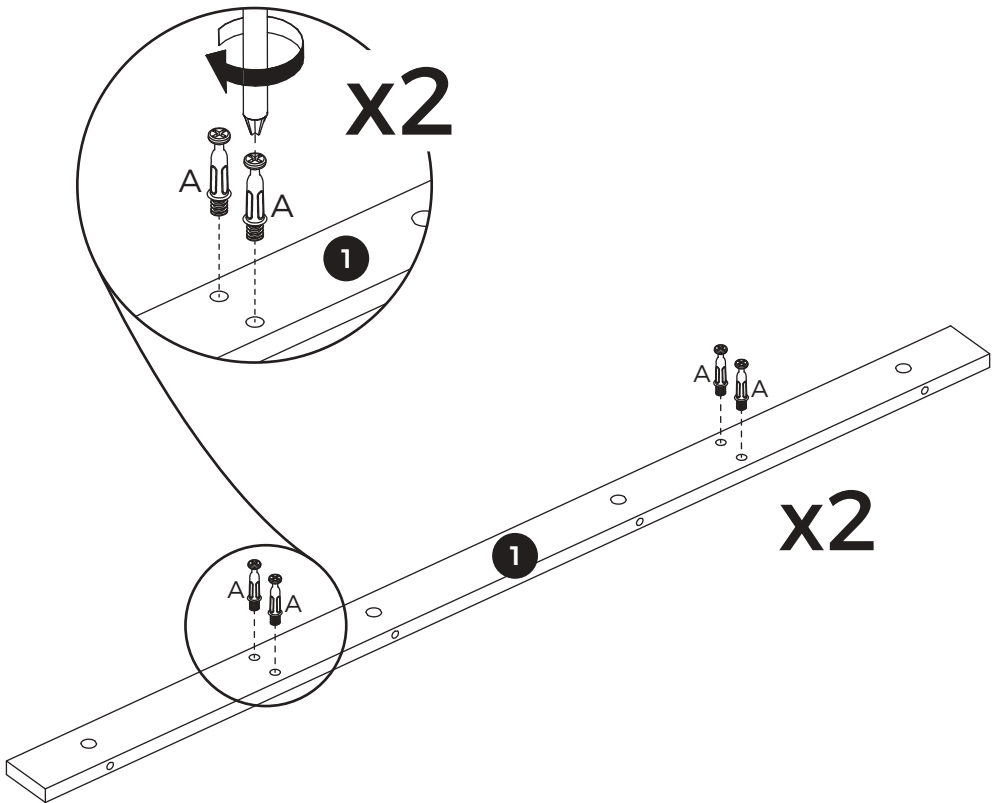

# 02



[EN] Connect panel 2 to panel 1 and tighten the cam lock (B) clockwise.

[ES] Conecte el panel 2 al panel 1 y apriete el cierre excéntrico (B) en el sentido de las agujas del reloj.

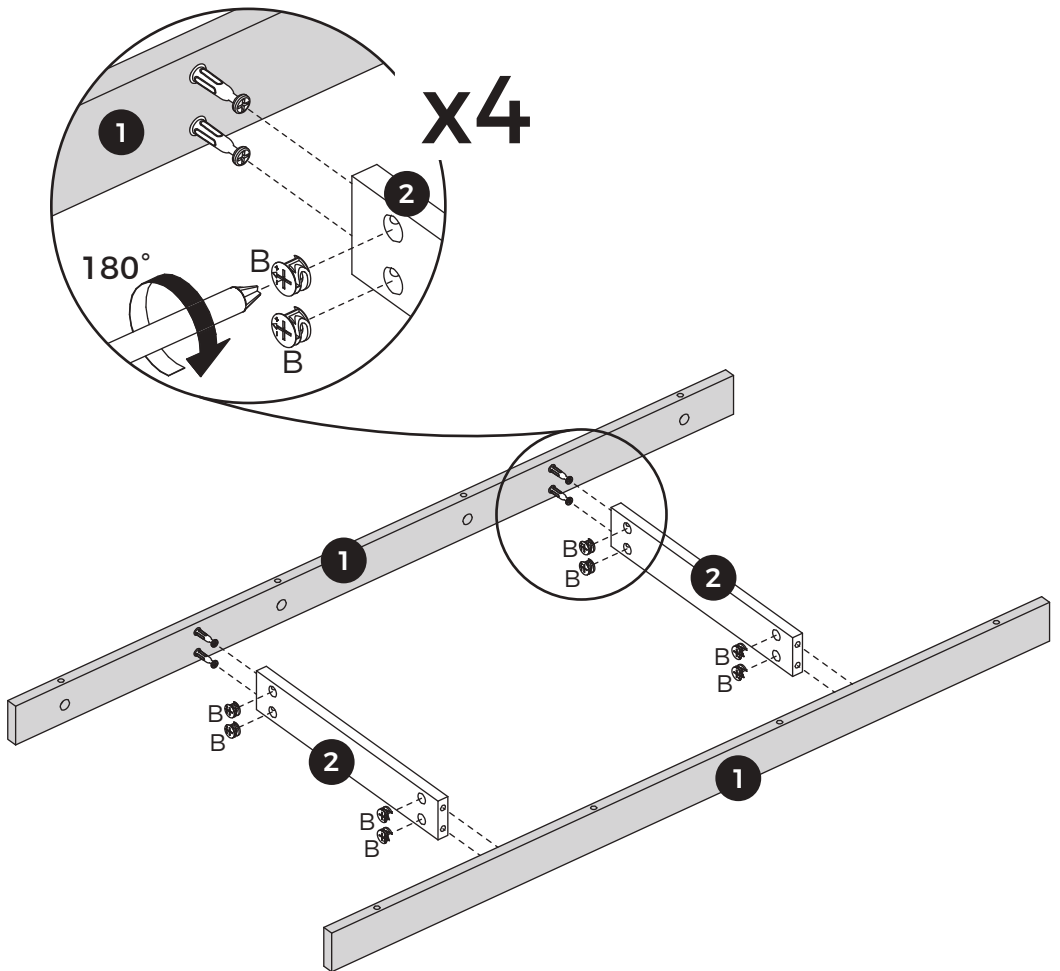

# 03



[EN] Screw eccentric rod (A) onto panel 3.

[ES] Enrosque la varilla excéntrica (A) en el panel 3.

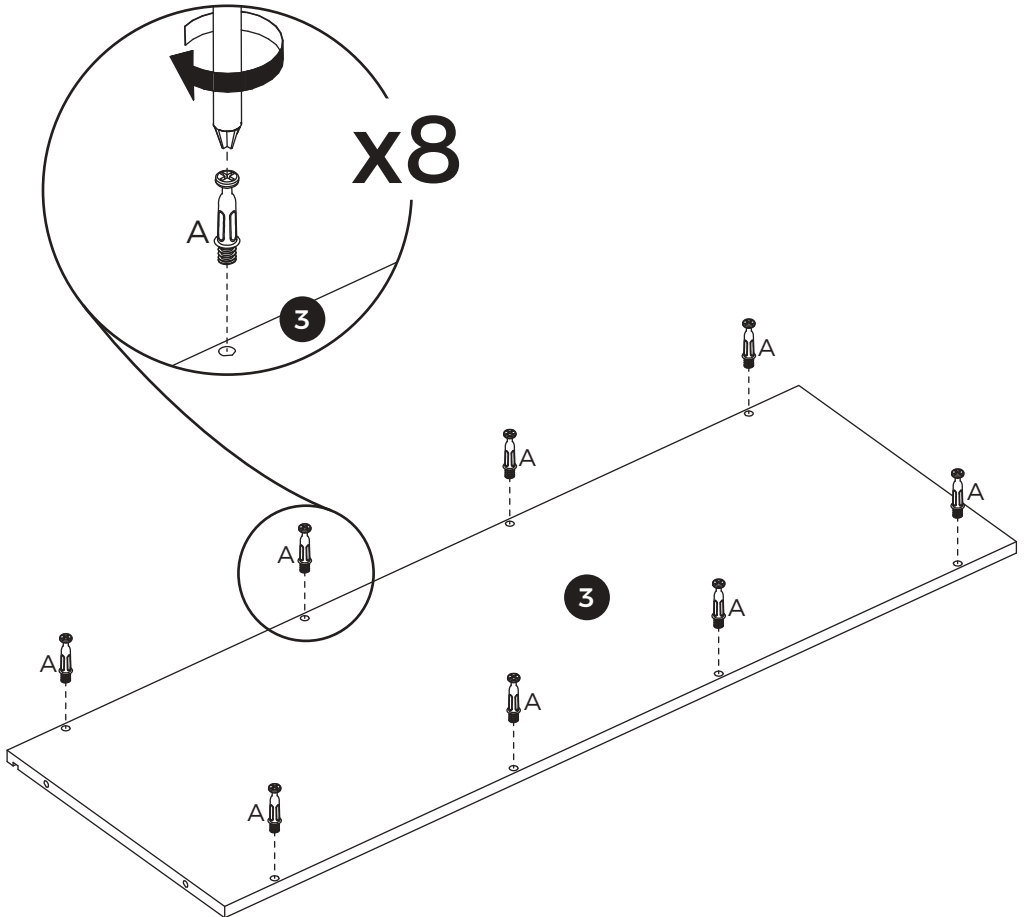

# 04



[EN] Connect panels 2 and 1 to panel 3 and tighten the cam lock (B) clockwise.

[ES] Conecte los paneles 2 y 1 al panel 3 y apriete el cierre excéntrico (B) en el sentido de las agujas del reloj.

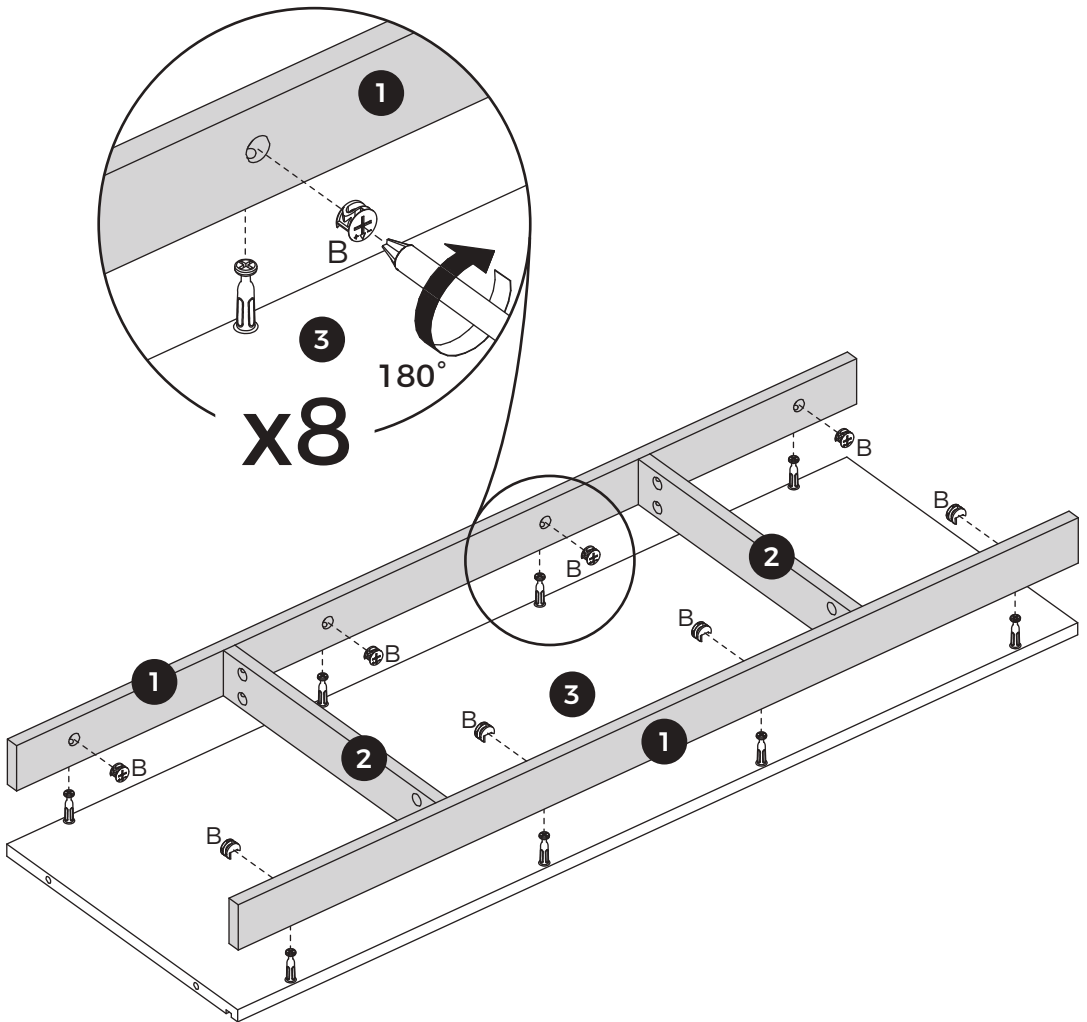



# 06



[EN] Connect panel 5 to panel 4 and tighten the cam lock (B) clockwise.

[ES] Conecte el panel 5 al panel 4 y apriete el cierre excéntrico (B) en el sentido de las agujas del reloj.

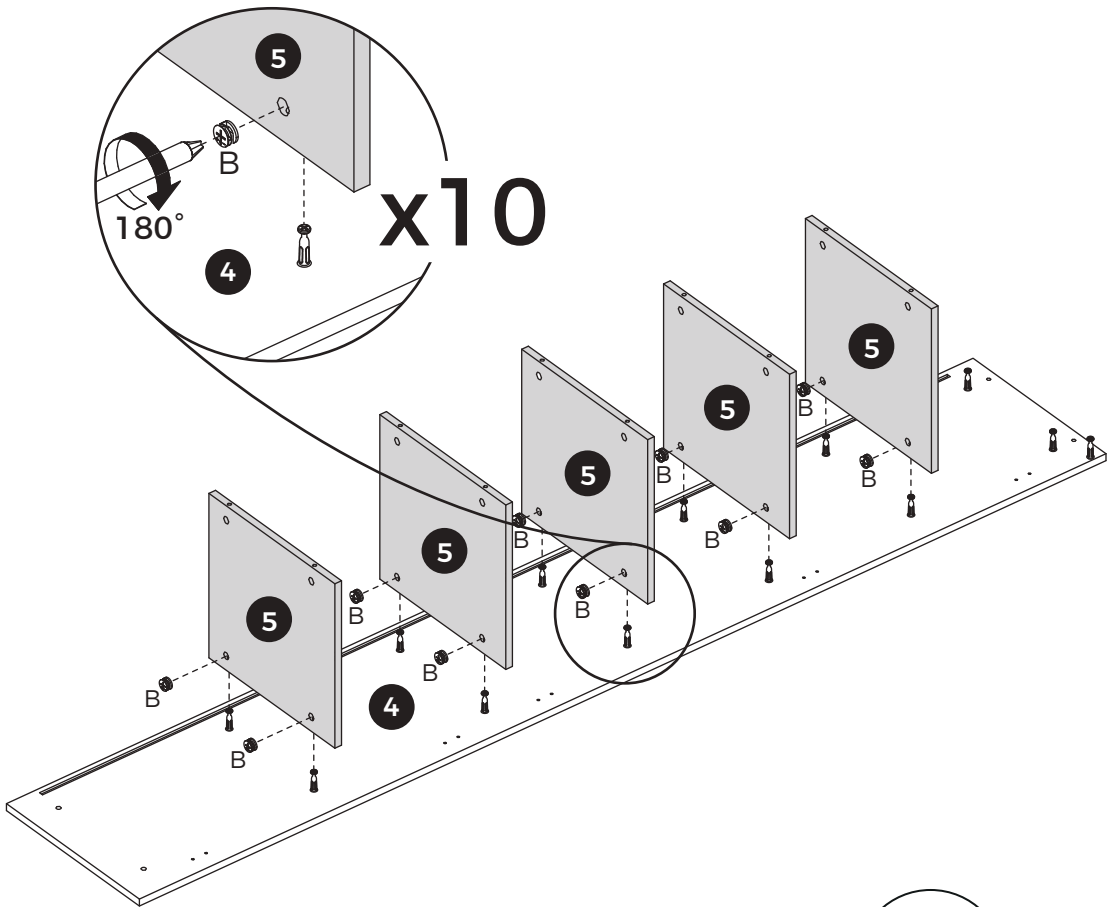

2 ADULTS

# 07

[EN] Insert back panel 6 along the grooves.

[ES] Inserte los paneles trasero 6 a lo largo de las ranuras.

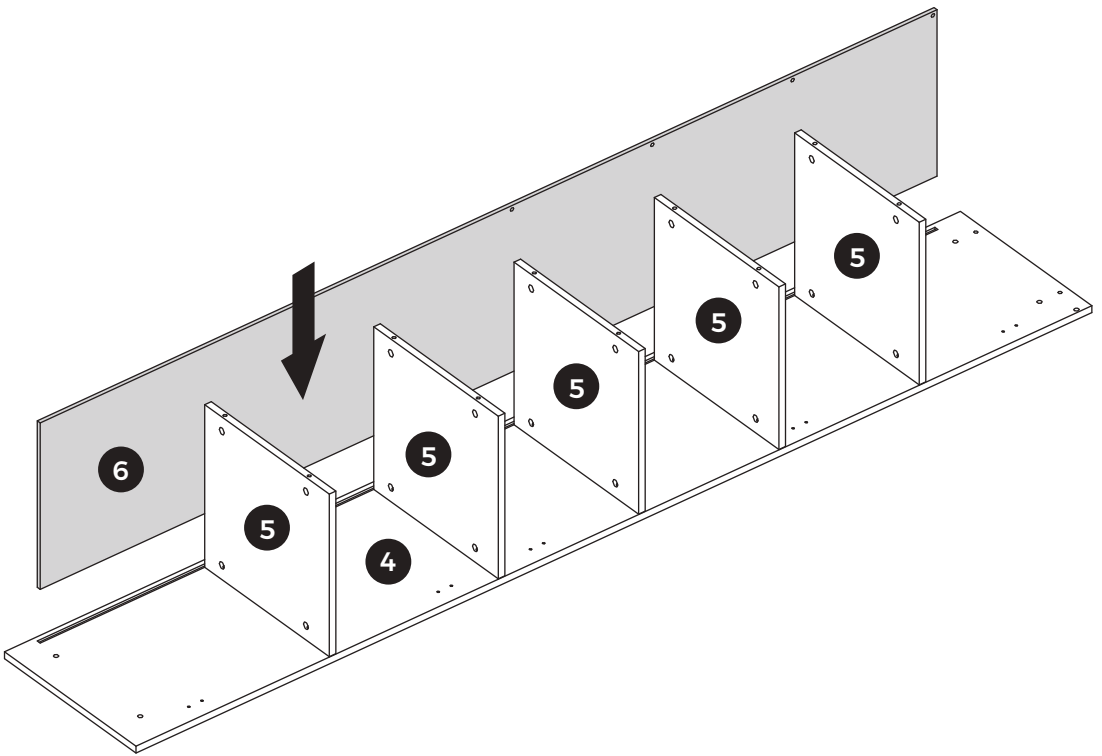

# 08

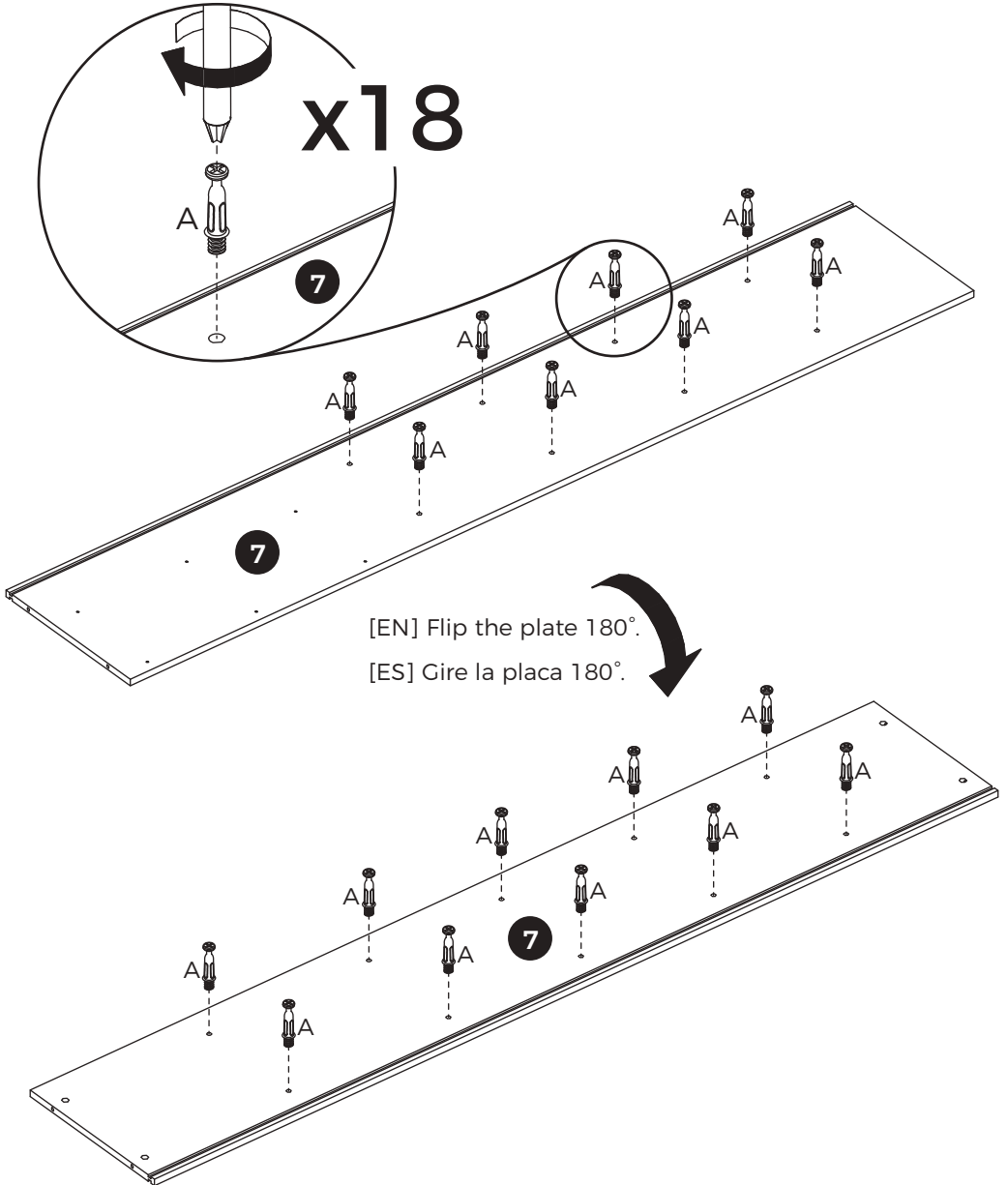

# 09



[EN] Connect panel 7 to panel 5 and tighten the cam lock (B) clockwise.

[ES] Conecte el panel 7 al panel 5 y apriete el cierre excéntrico (B) en el sentido de las agujas del reloj.

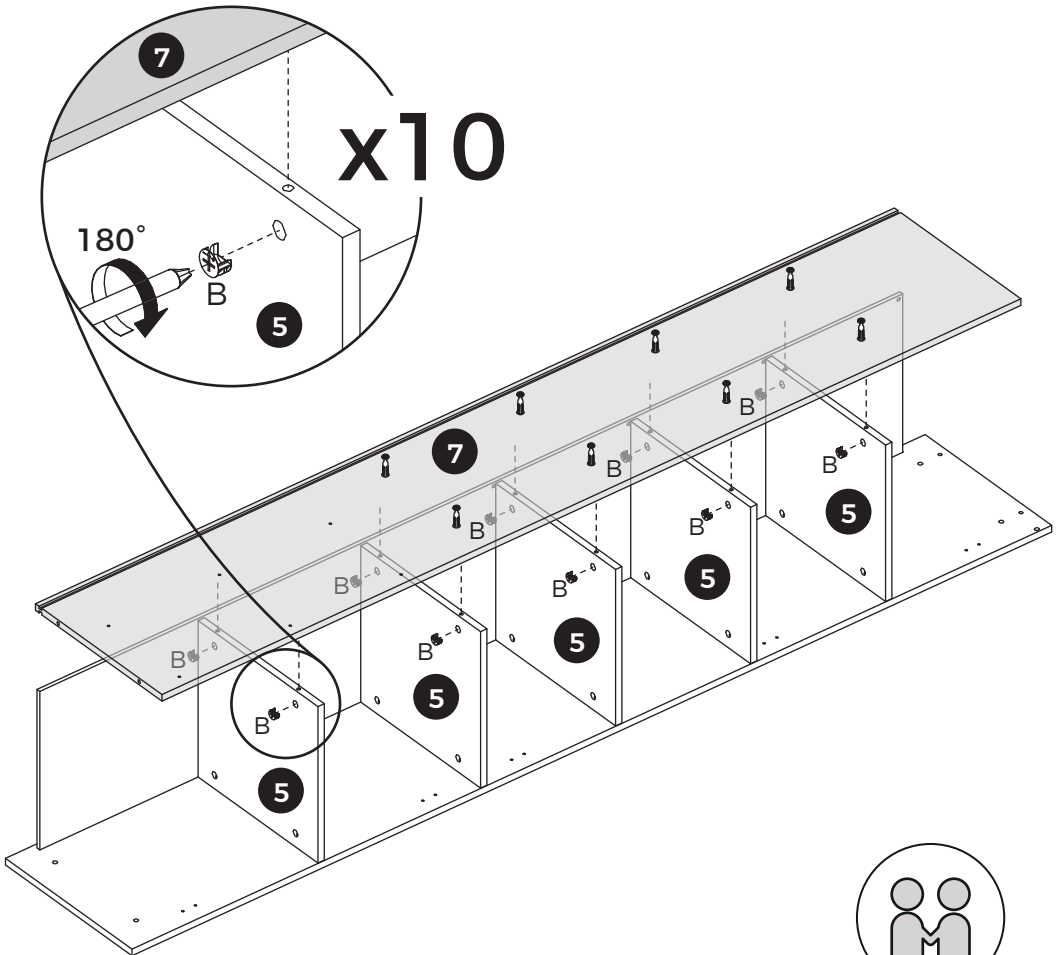

2 ADULTS

# 10

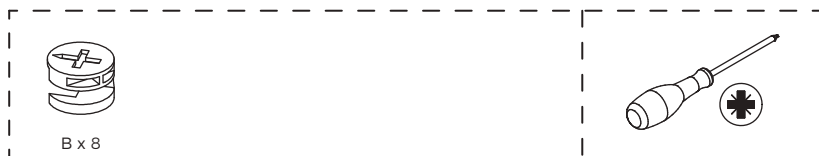

[EN] Connect panel 8 to panel 7 and tighten the cam lock (B) clockwise.

[ES] Conecte el panel 8 al panel 7 y apriete el cierre excéntrico (B) en el sentido de las agujas del reloj.

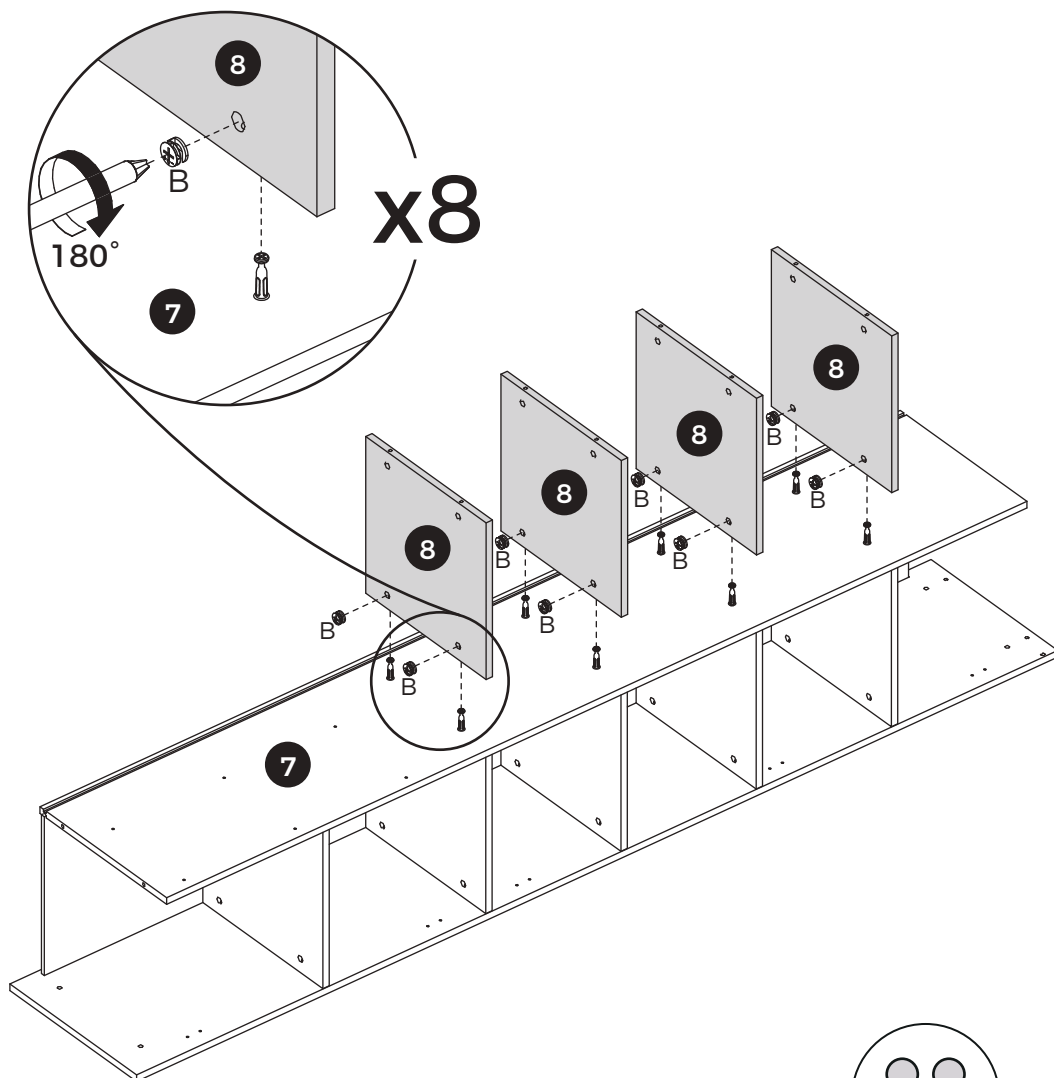

2 ADULTS

# 11

[EN] Insert back panel 6 along the grooves.

[ES] Inserte los paneles trasero 6 a lo largo de las ranuras.

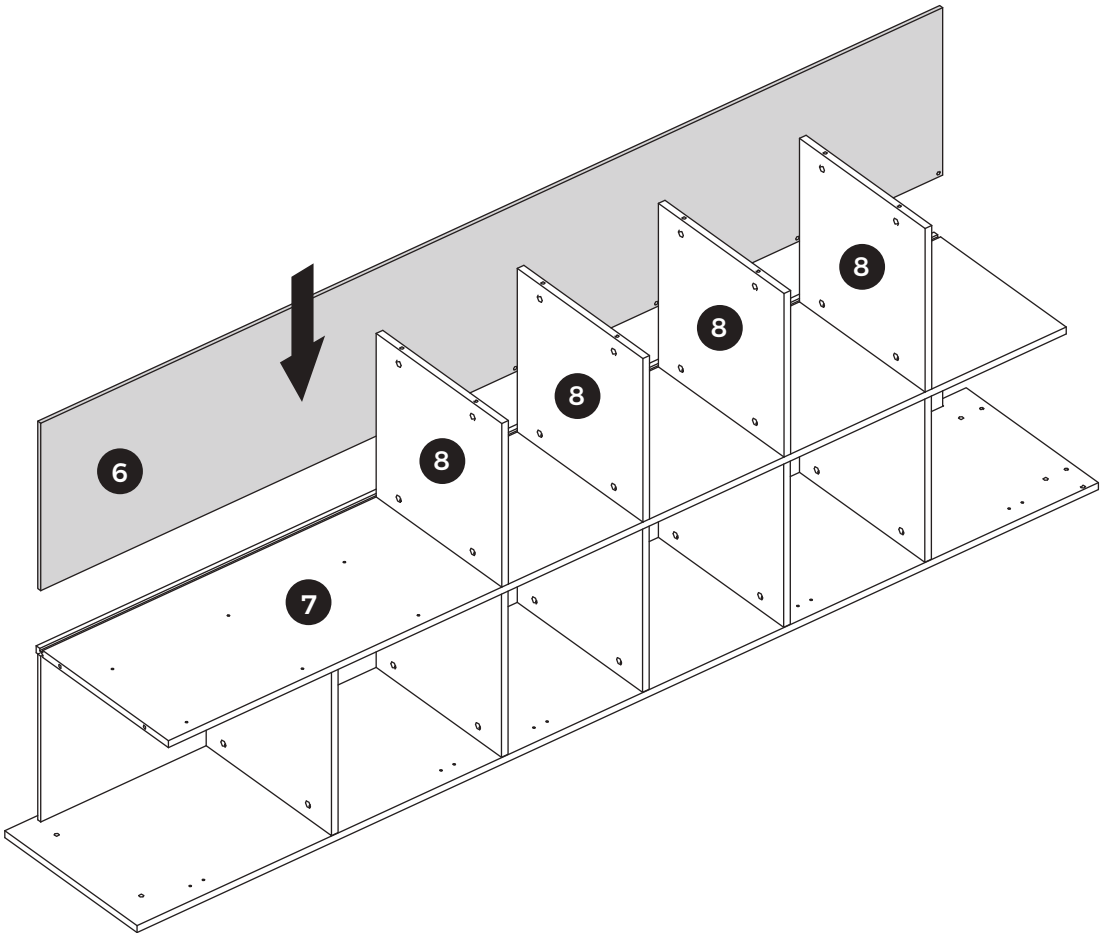



# 13

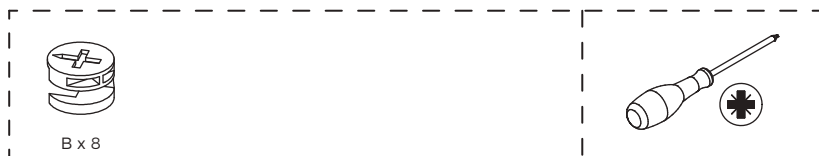

[EN] Connect panel 9 to panel 8 and tighten the cam lock (B) clockwise.

[ES] Conecte el panel 9 al panel 8 y apriete el cierre excéntrico (B) en el sentido de las agujas del reloj.

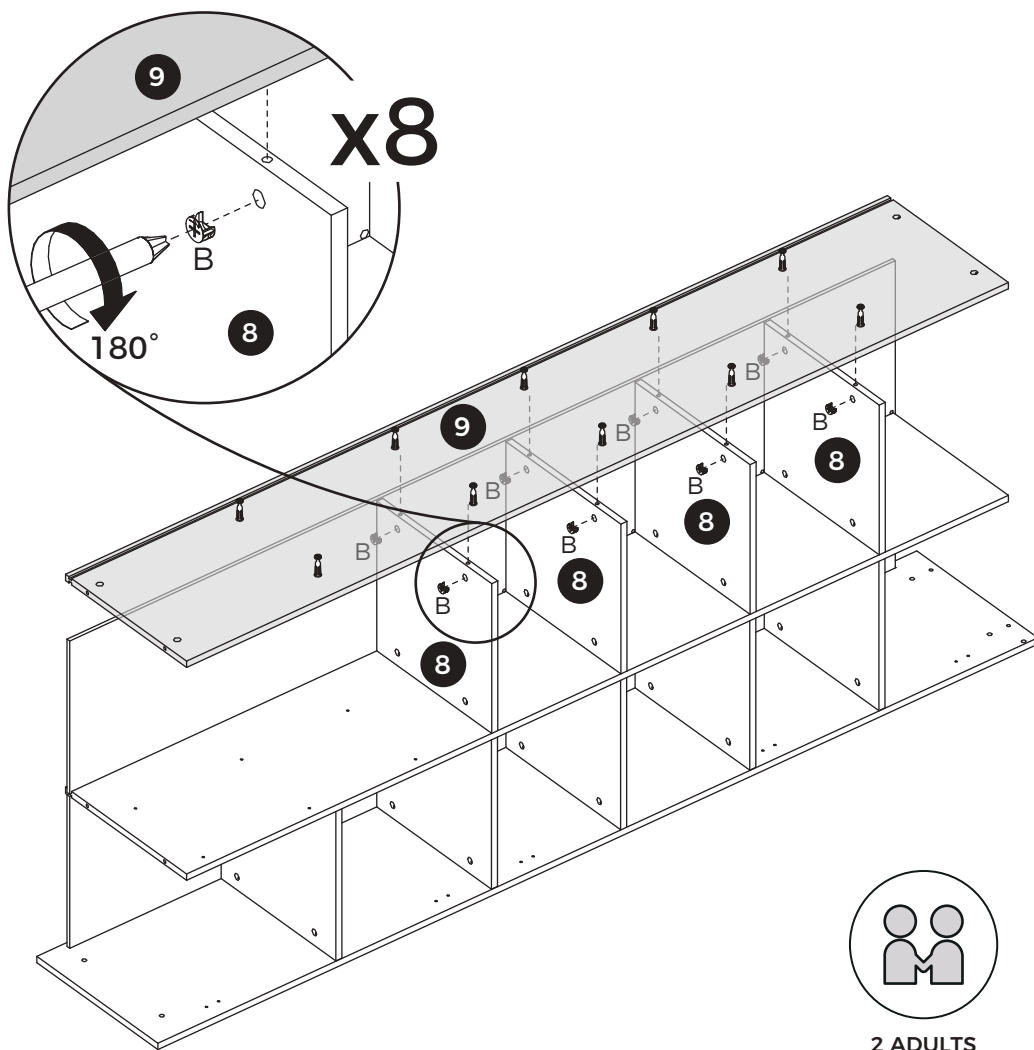



# 15

[EN] Insert back panel 6 along the grooves.

[ES] Inserte los paneles trasero 6 a lo largo de las ranuras.

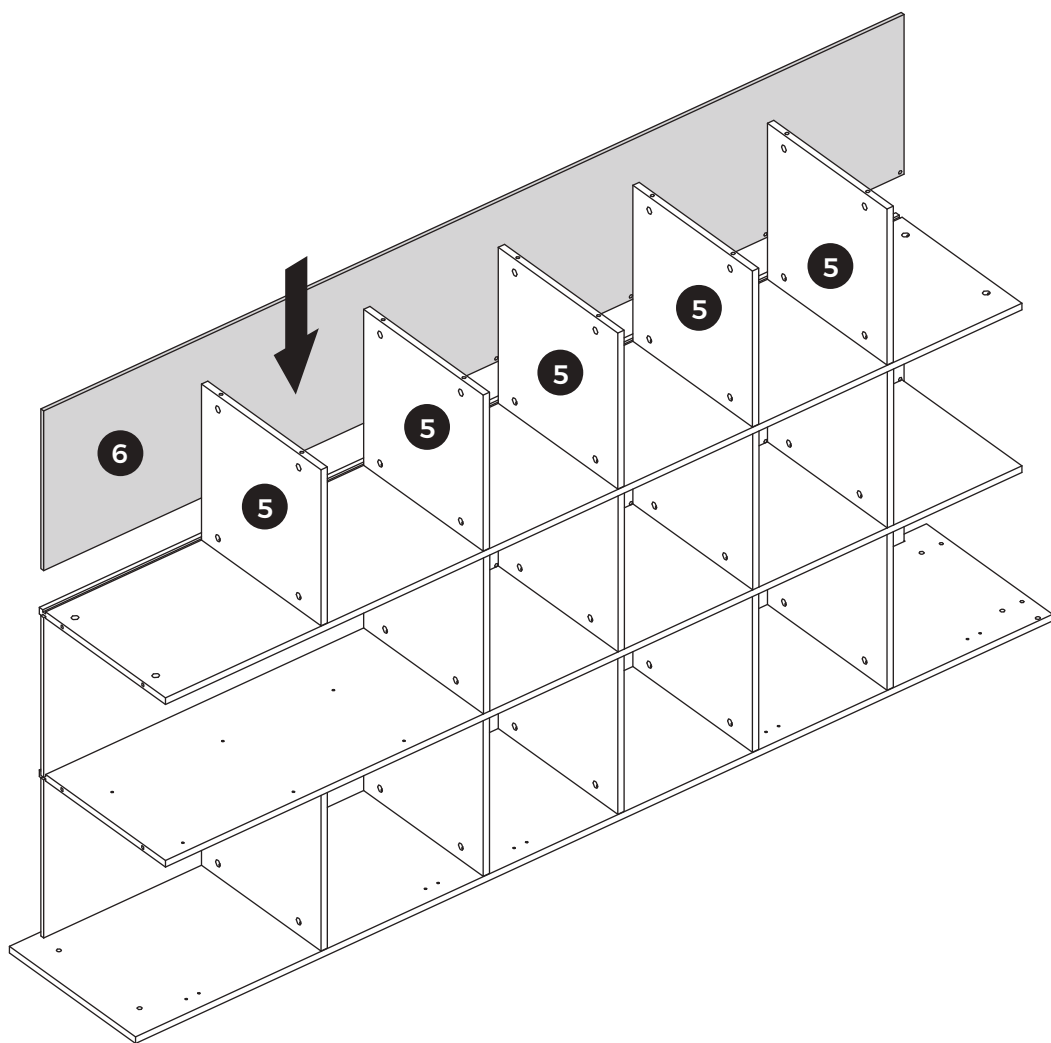

# 16

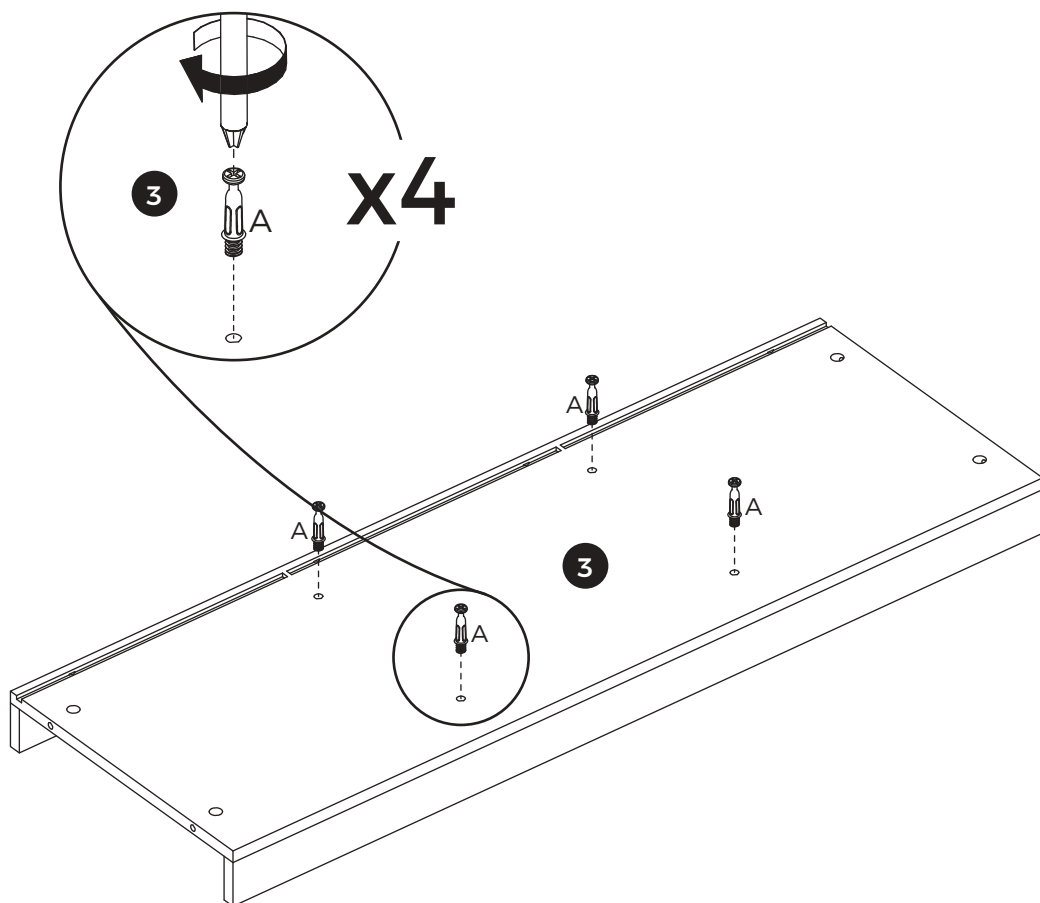

# 17



B x 6

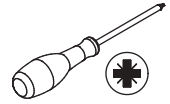

[EN] Connect panel 3 to panels 4, 7 and 9 and tighten the cam lock (B) clockwise.

[ES] Conecte el panel 3 a los paneles 4, 7 y 9 y apriete el cierre excéntrico (B) en el sentido de las agujas del reloj.

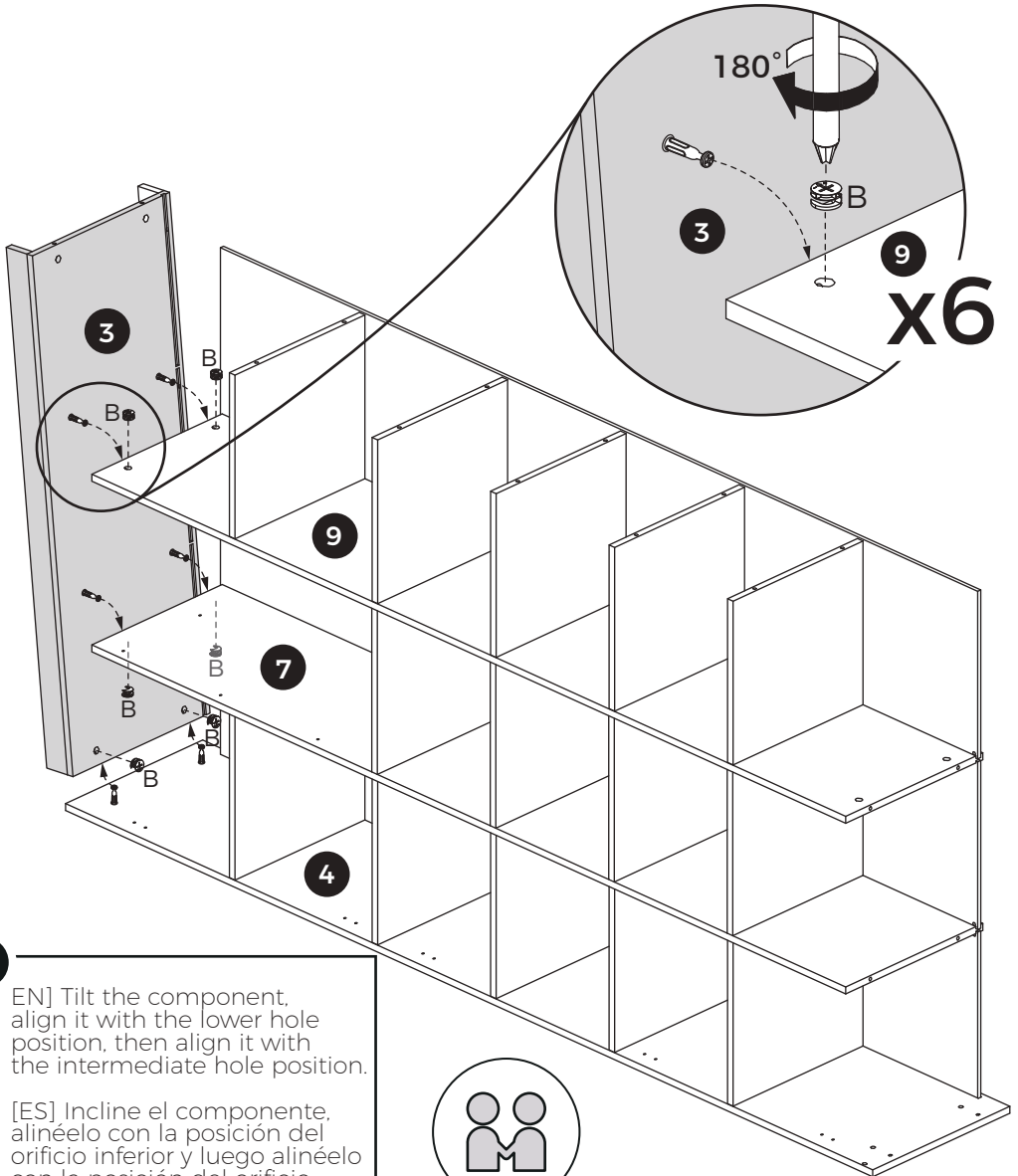

[EN] Tilt the component, align it with the lower hole position, then align it with the intermediate hole position.

[ES] Incline el componente, alinéelo con la posición del orificio inferior y luego alinéelo con la posición del orificio intermedio.



2 ADULTS

# 18



[EN] Screw eccentric rod (A) onto panel 10.

[ES] Enrosque la varilla excéntrica (A) en el panel 10.

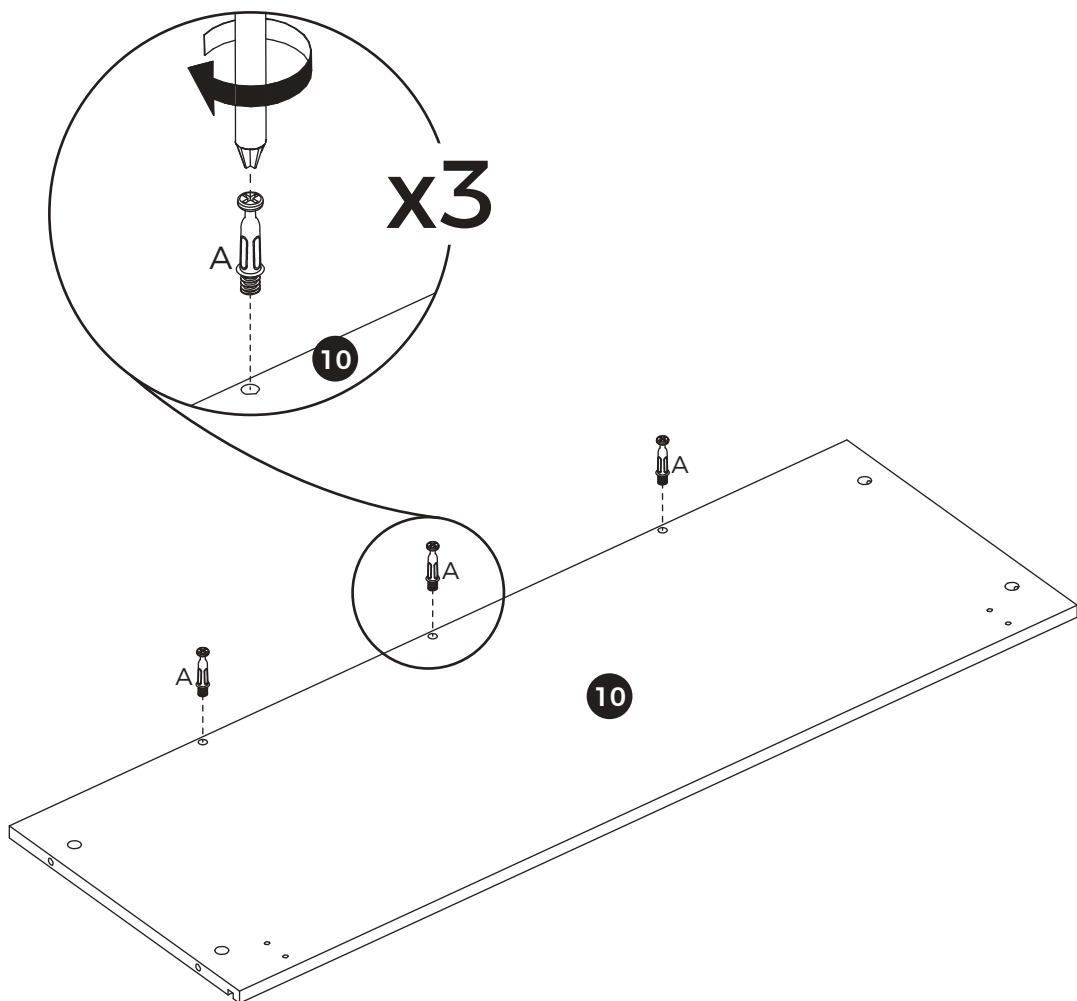

# 19



[EN] Connect panel 11 to panel 10 and tighten the cam lock (B) clockwise.

[ES] Conecte el panel 11 al panel 10 y apriete el cierre excéntrico (B) en el sentido de las agujas del reloj.

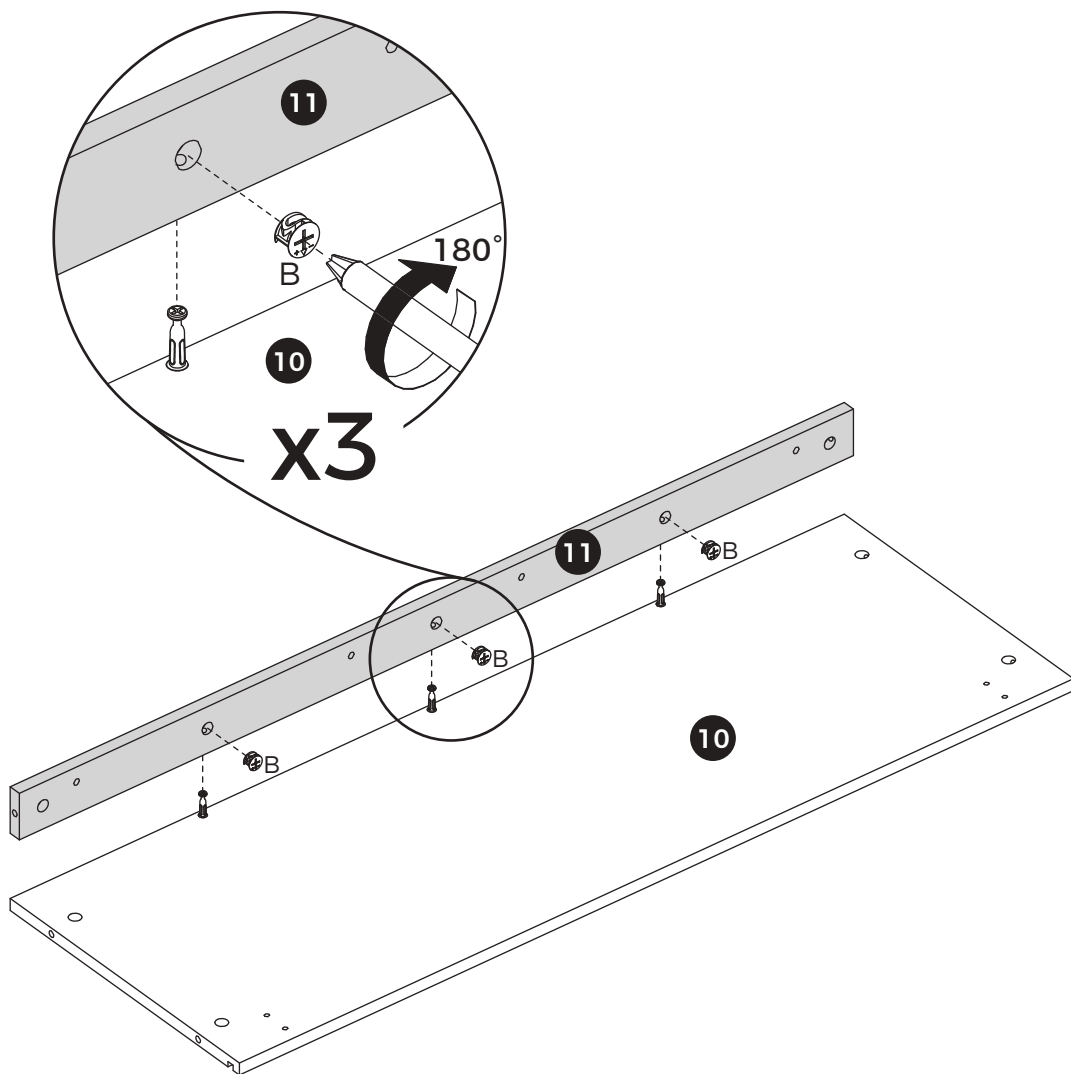

# 20

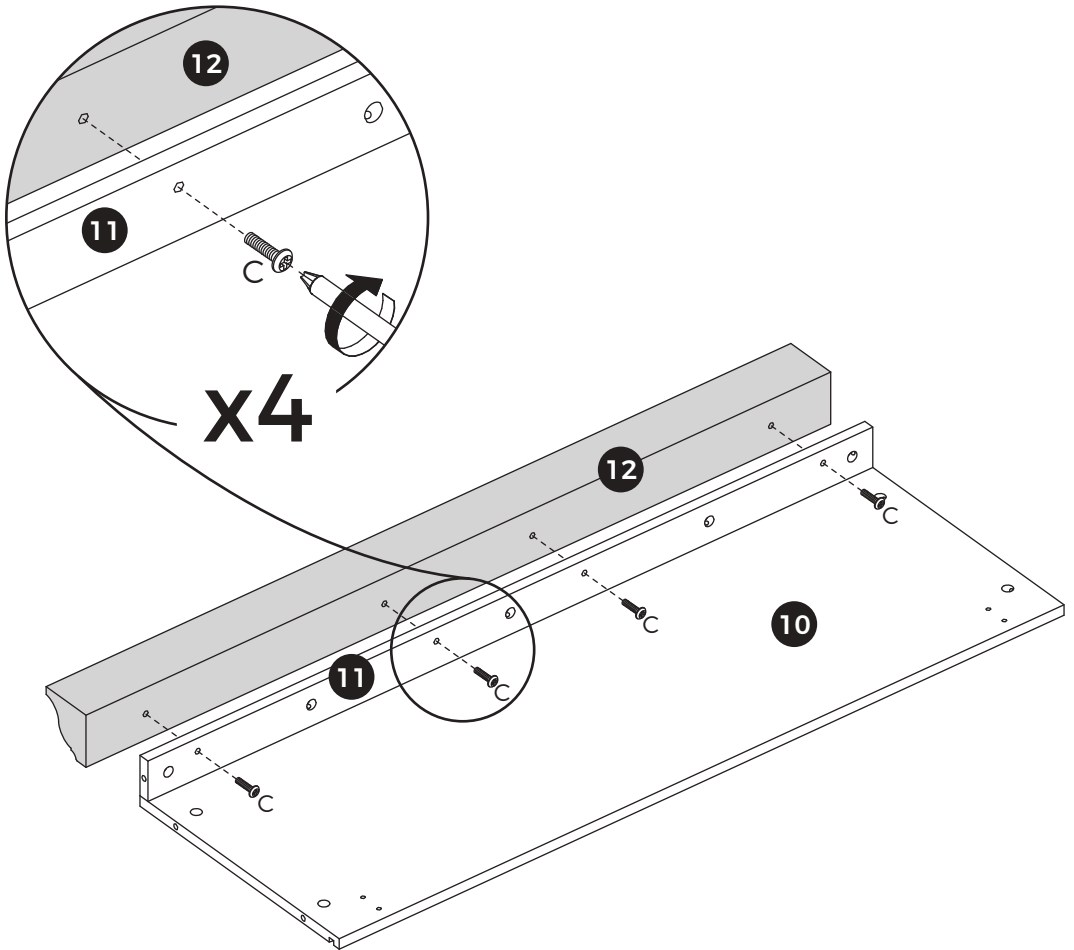

# 21



[EN] Screw eccentric rod (A) onto panel 10.

[ES] Enrosque la varilla excéntrica (A) en el panel 10.

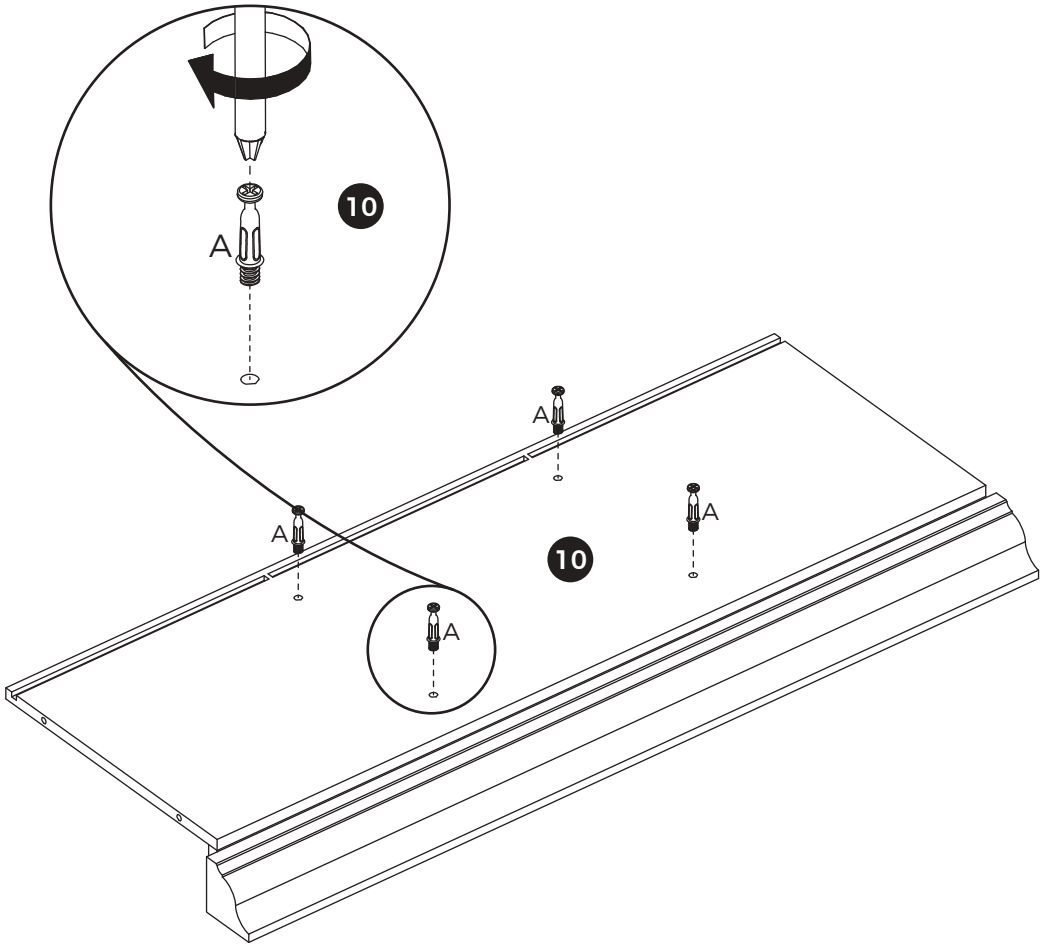

# 22



B x 4

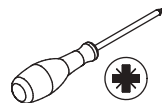

[EN] Connect panel 10 to panels 4, 7 and 9 and tighten the cam lock (B) clockwise.

[ES] Conecte el panel 10 a los paneles 4, 7 y 9 y apriete el cierre excéntrico (B) en el sentido de las agujas del reloj.

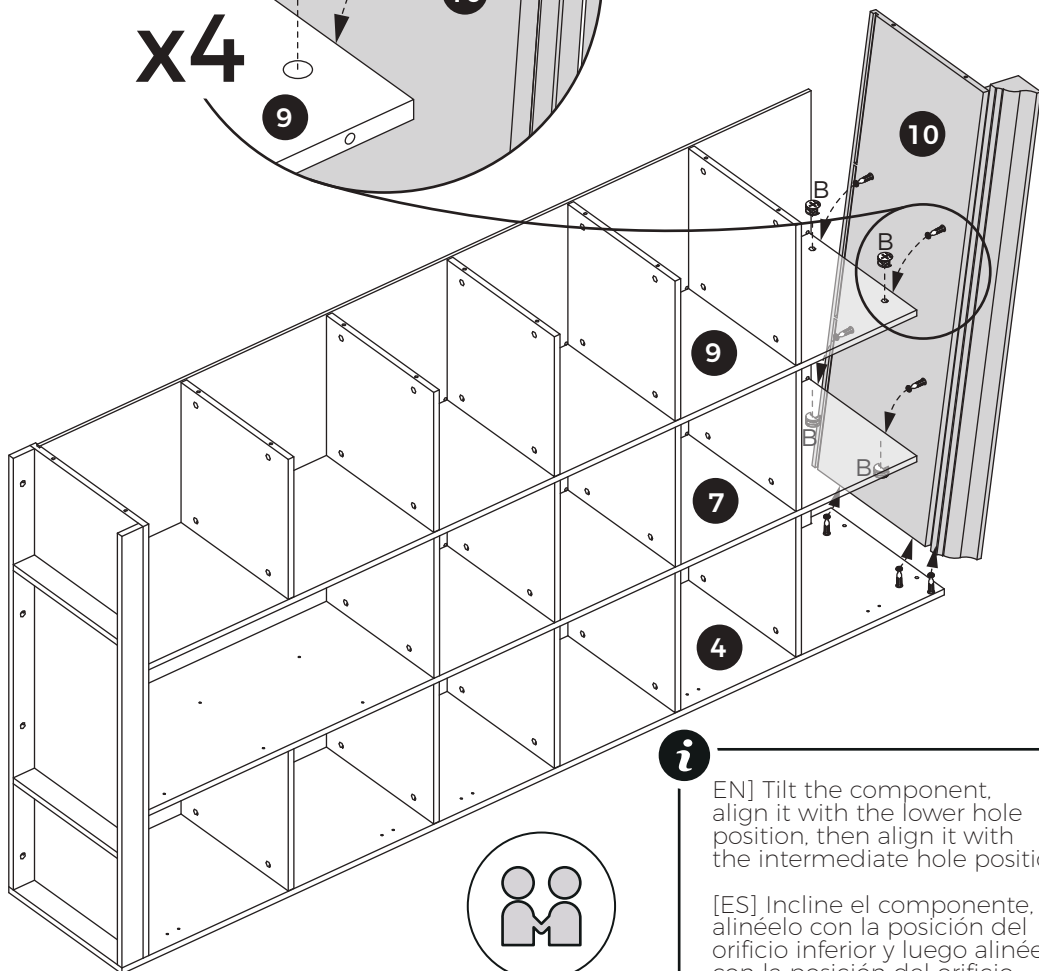
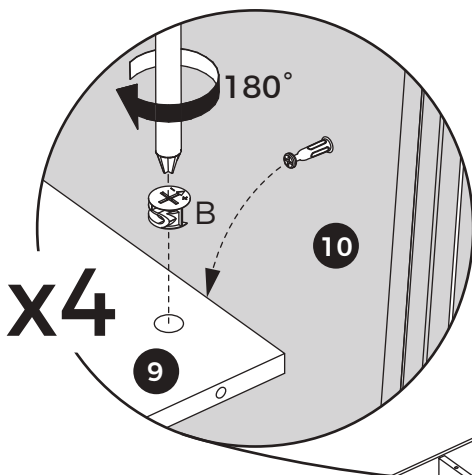

[EN] Tilt the component, align it with the lower hole position, then align it with the intermediate hole position.

[ES] Incline el componente, alinéelo con la posición del orificio inferior y luego alinéelo con la posición del orificio intermedio.

2 ADULTS

# 23



[EN] Insert cam lock (B) into the holes of panels 10 and 11 and tighten clockwise.

[ES] Inserte el cierre excéntrico (B) en los orificios de los paneles 10 y 11 y apriételo en el sentido de las agujas del reloj.

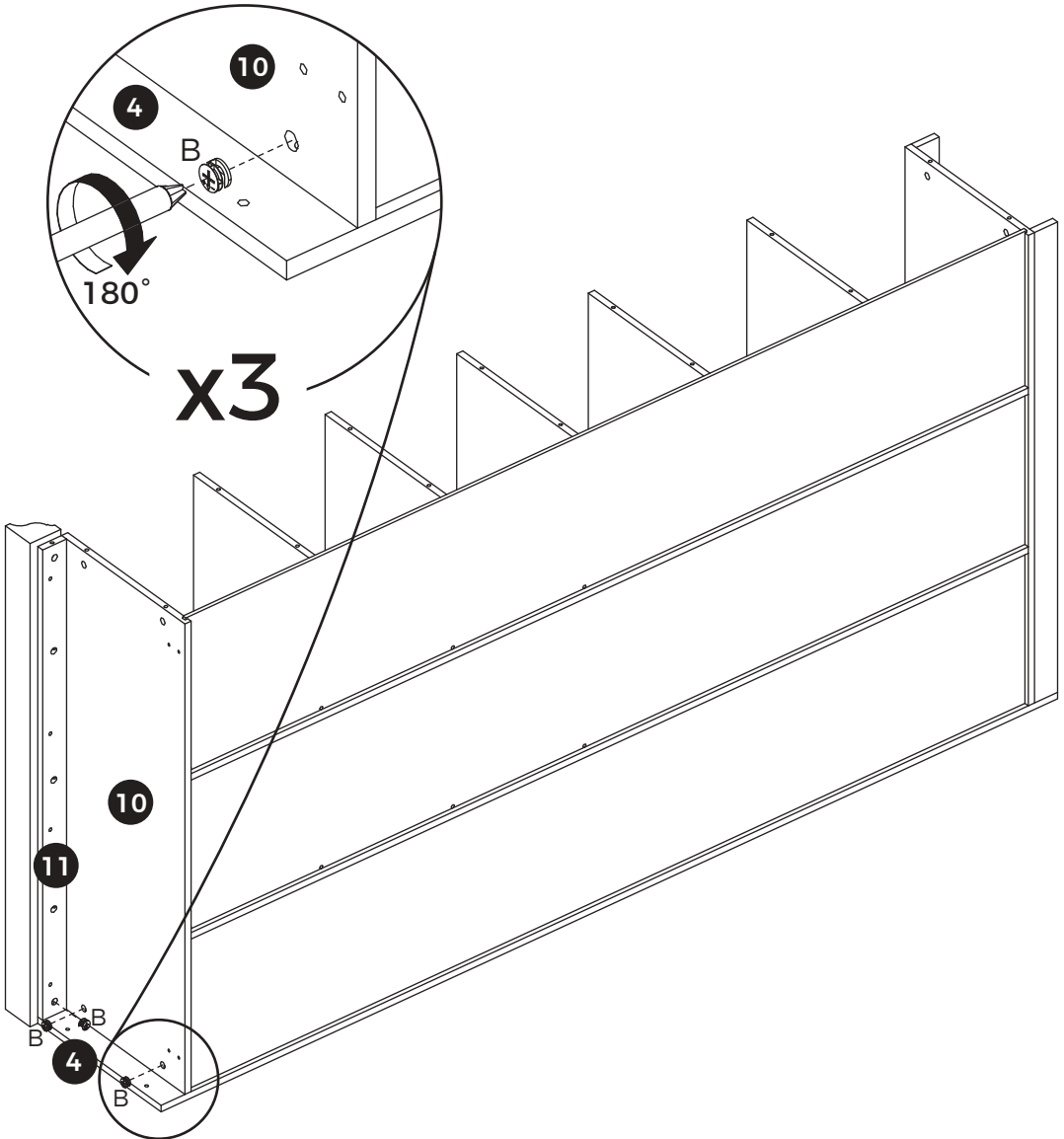

# 24

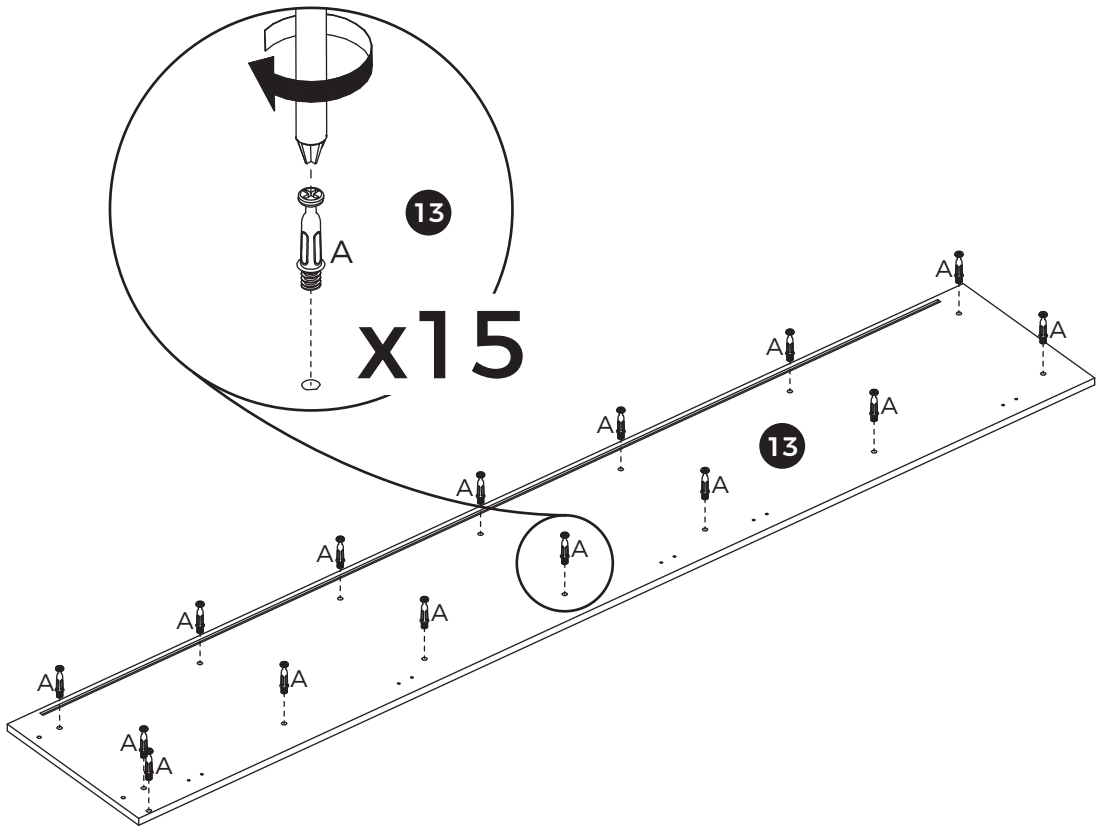

# 25



B x 12

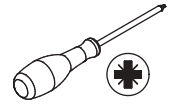

[EN] Connect panel 13 to panels 3, 5 and 10 and tighten the cam lock (B) clockwise.

[ES] Conecte el panel 13 a los paneles 3, 5 y 10 y apriete el cierre excéntrico (B) en el sentido de las agujas del reloj.

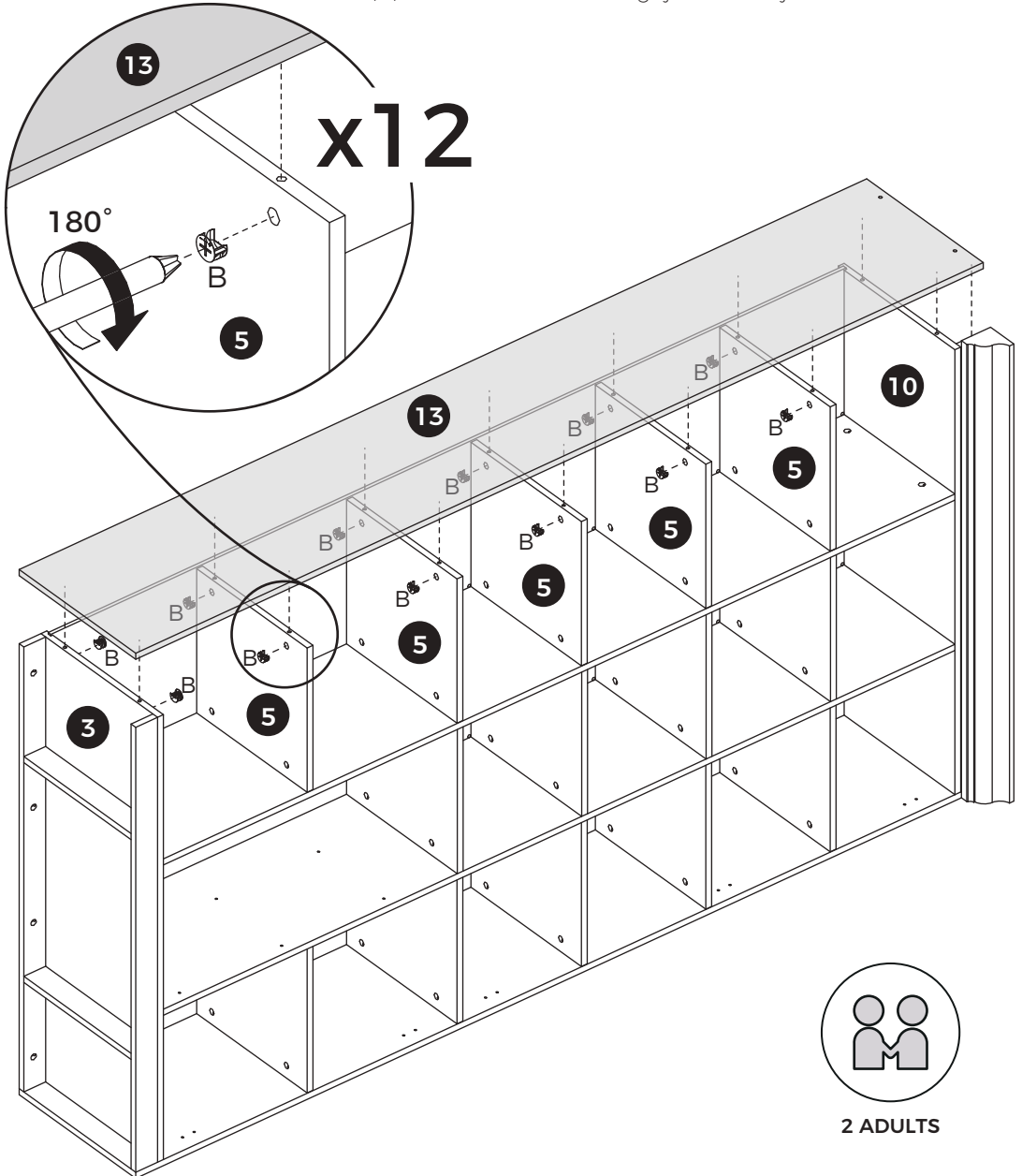

# 26



B x 3

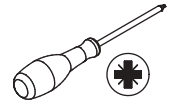

[EN] Insert cam lock (B) into the holes of panels 10 and 11 and tighten clockwise.

[ES] Inserte el cierre excéntrico (B) en los orificios de los paneles 10 y 11 y apriételo en el sentido de las agujas del reloj.

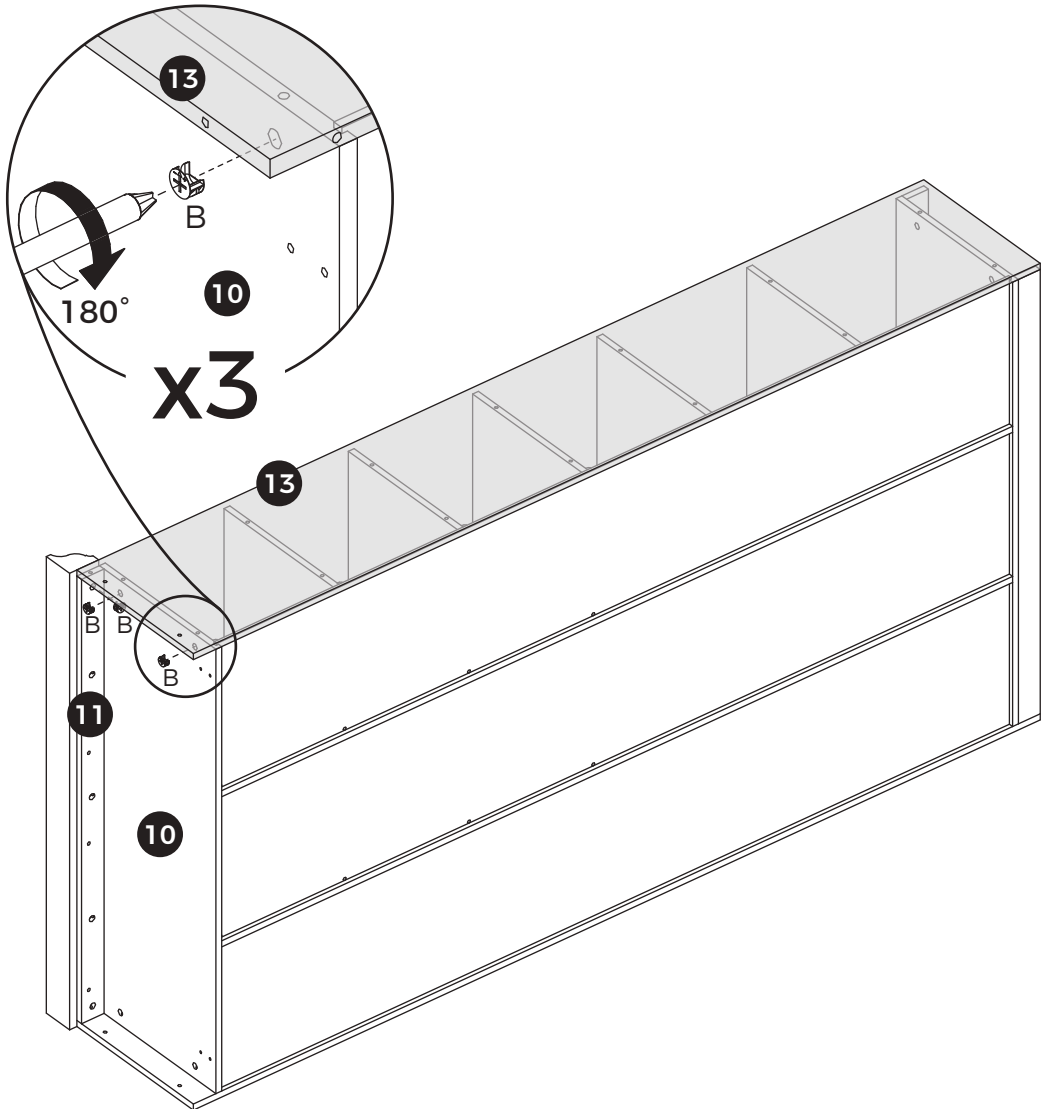

# 27

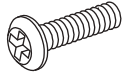

C x 2

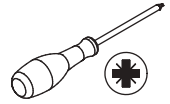

[EN] Secure part 14 to panel 13 with screw (C).

[ES] Fije la pieza 14 al panel 13 con el tornillo (C).

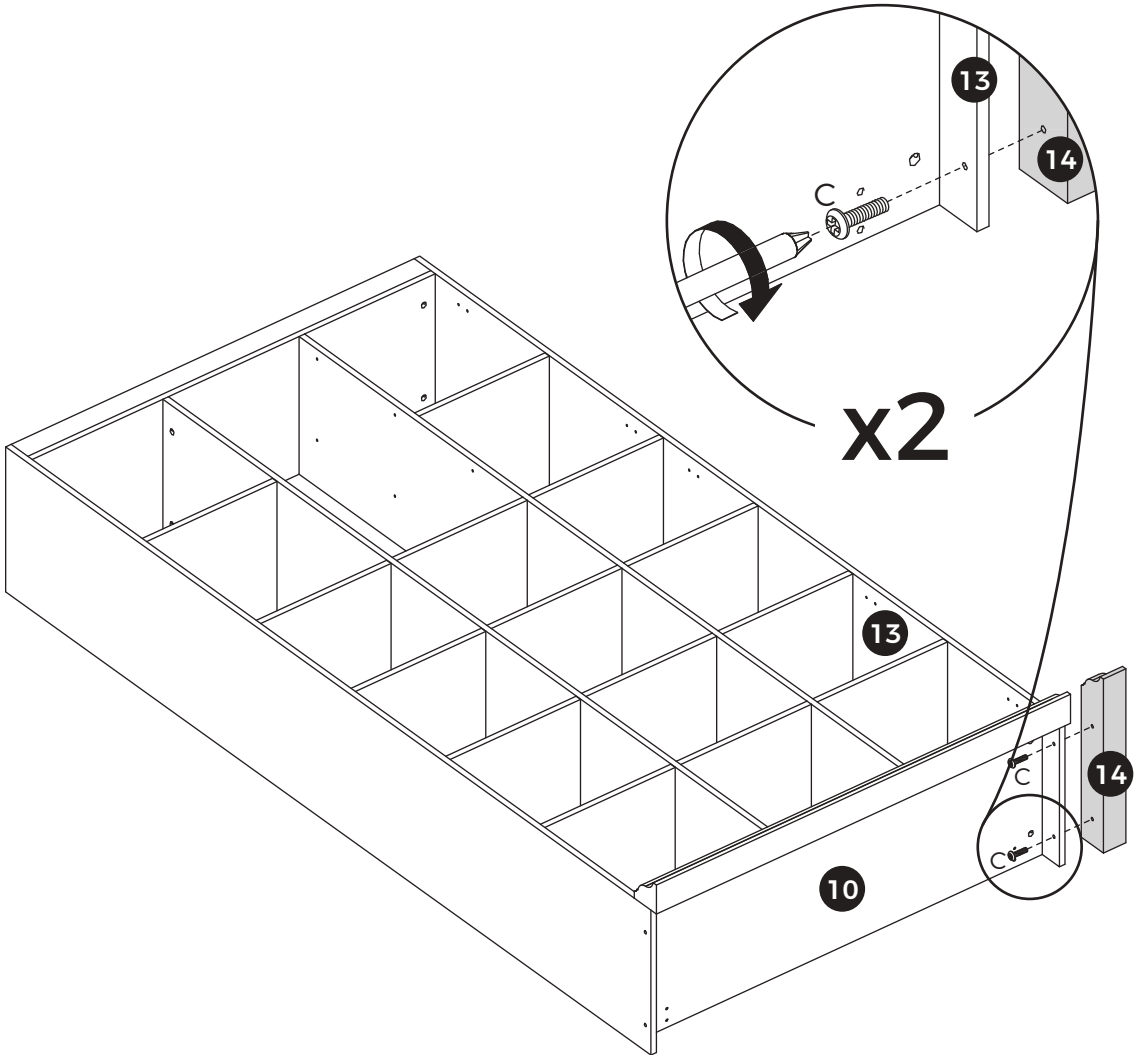

# 28



[EN] Secure part 15 to panel 7 with screw (C).

[ES] Fije la pieza 15 al panel 7 con el tornillo (C).

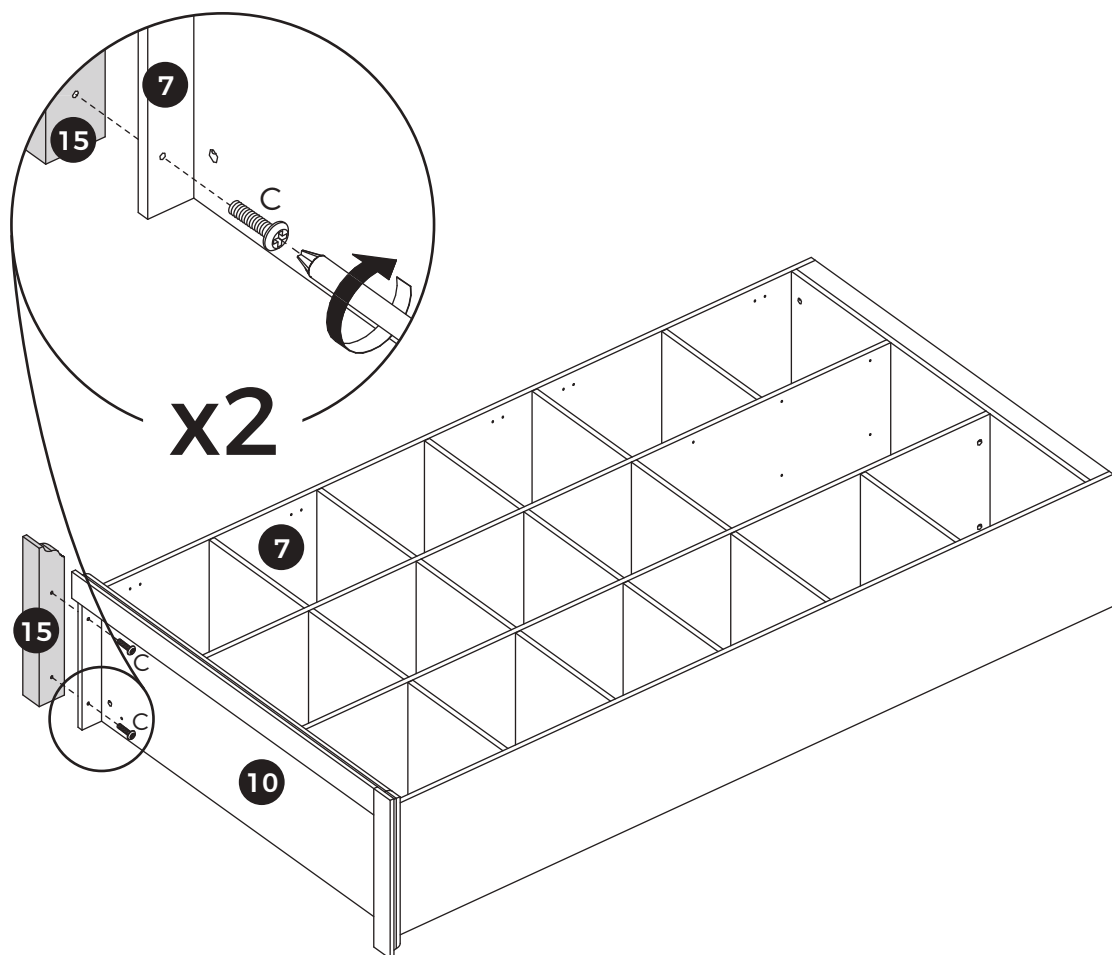

# 29

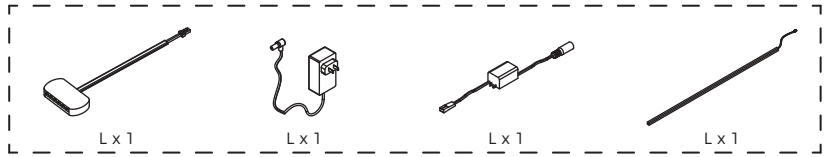

[EN] This figure shows how the light strip, junction box, switch, and plug are connected.

[ES] Esta figura muestra cómo se conectan la tira de luz, la caja de conexiones, el interruptor y el enchufe.

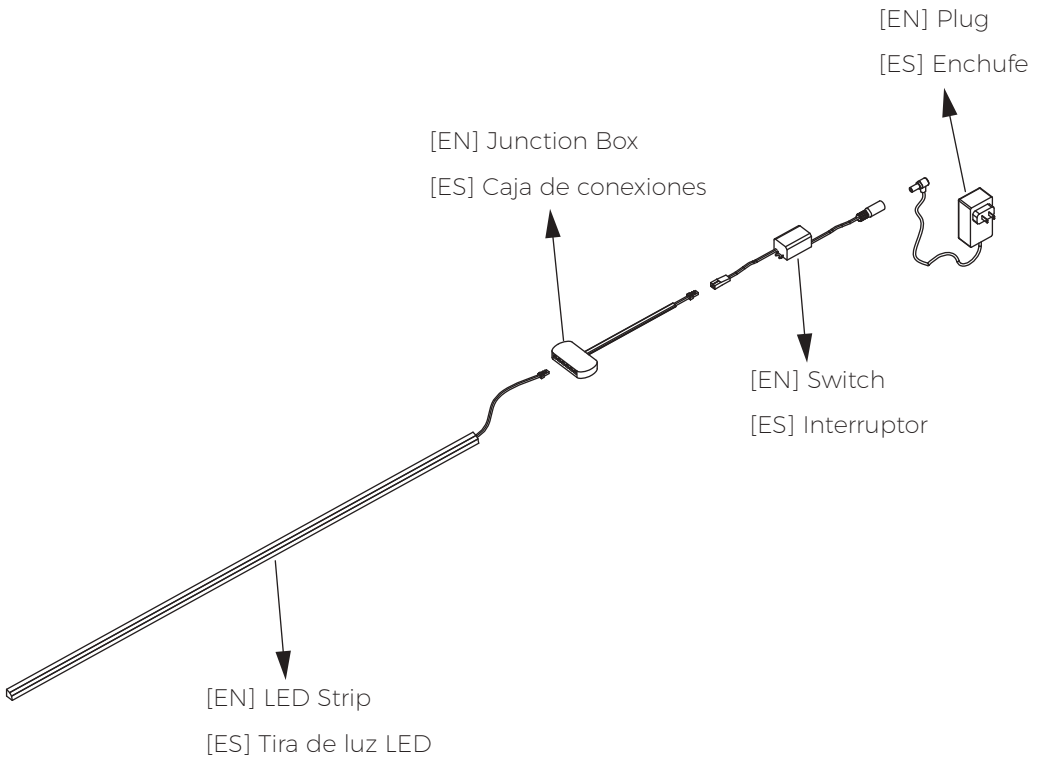

# 30

[EN] This figure shows the process of peeling off the tape on the light strip and then adhering it to the rear area of panel9.

[ES] Esta figura muestra el proceso de despegar la cinta de la tira de luz y luego adherirla a la parte trasera de los panele9.

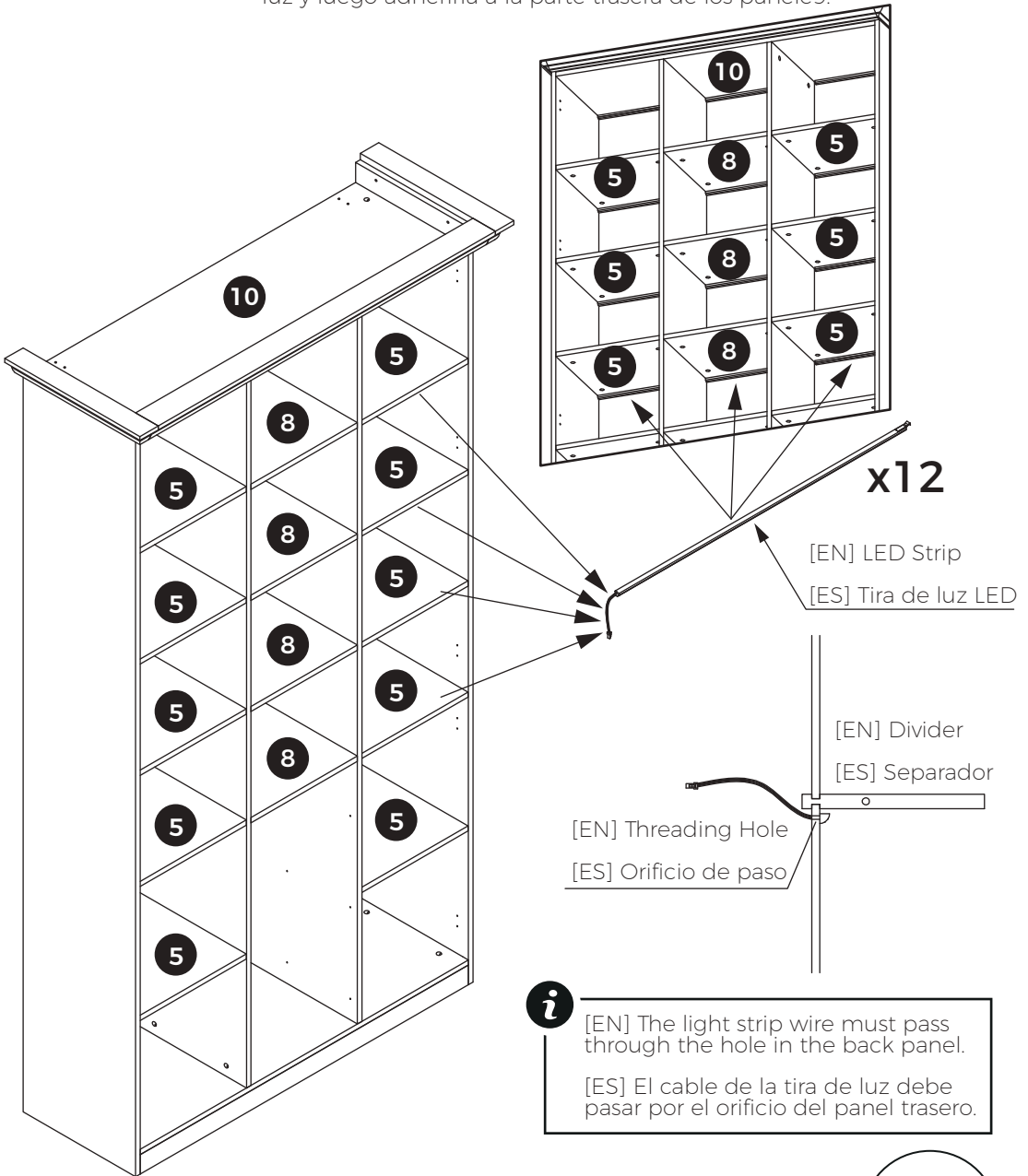

2 ADULTS

# 31

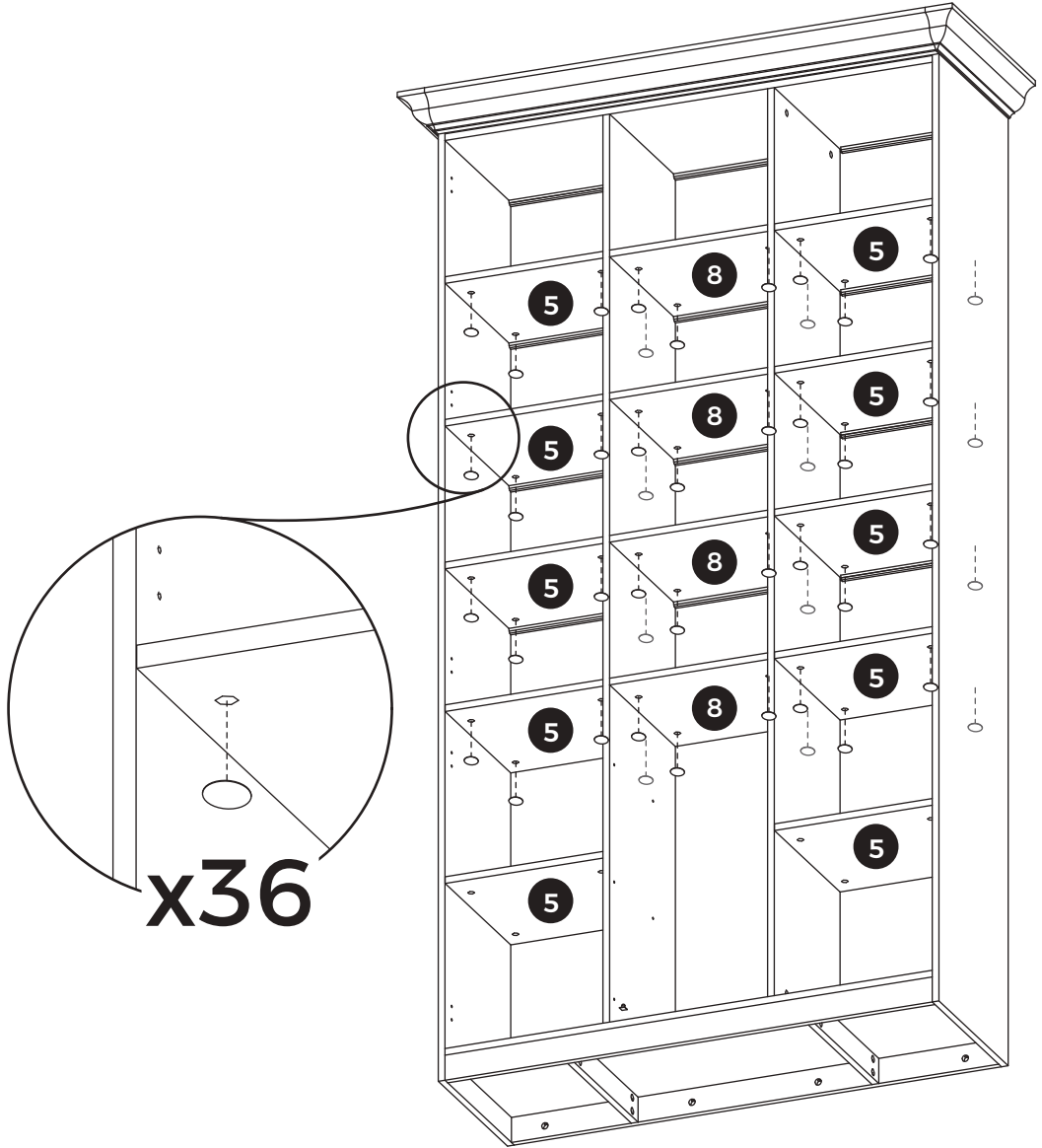

# 32

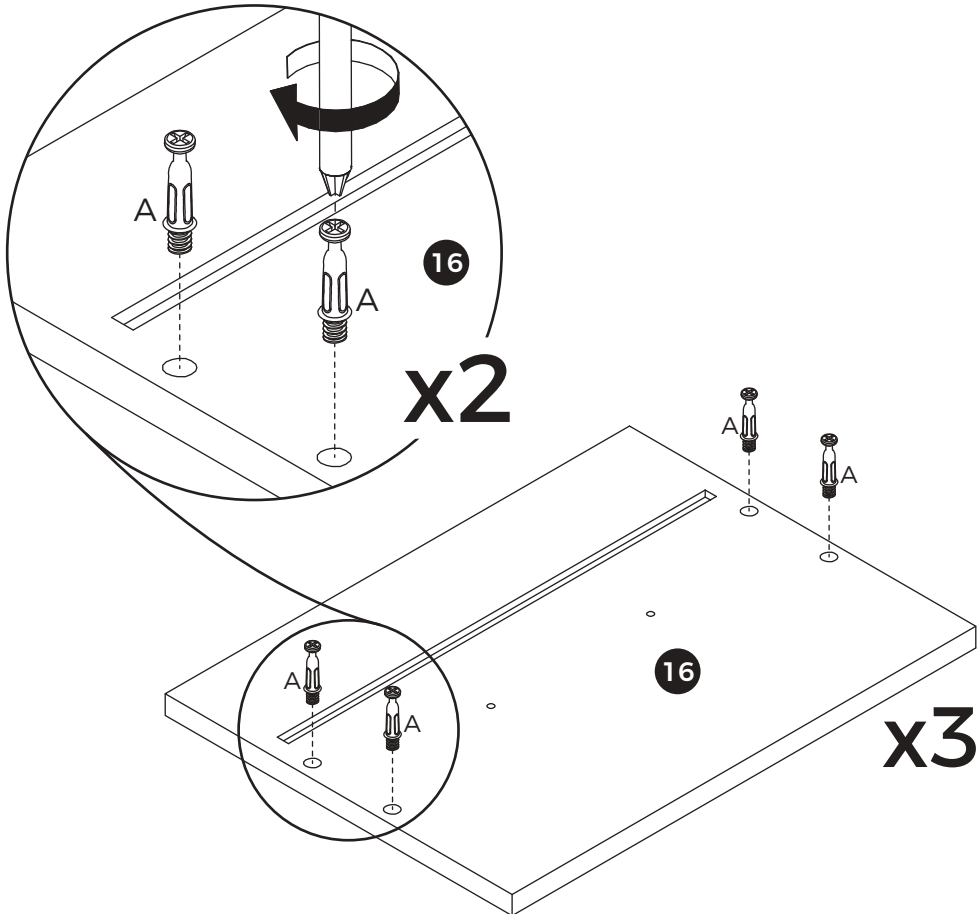

# 33



B x 12

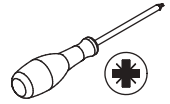

[EN] Connect panels 17 and 18 to panel 16, then tighten cam lock (B) clockwise. Insert panel 19 into the grooves.

[ES] Conecte los paneles 17 y 18 al panel 16 y apriete la leva (B) en sentido horario. Inserte el panel 19 en las ranuras.

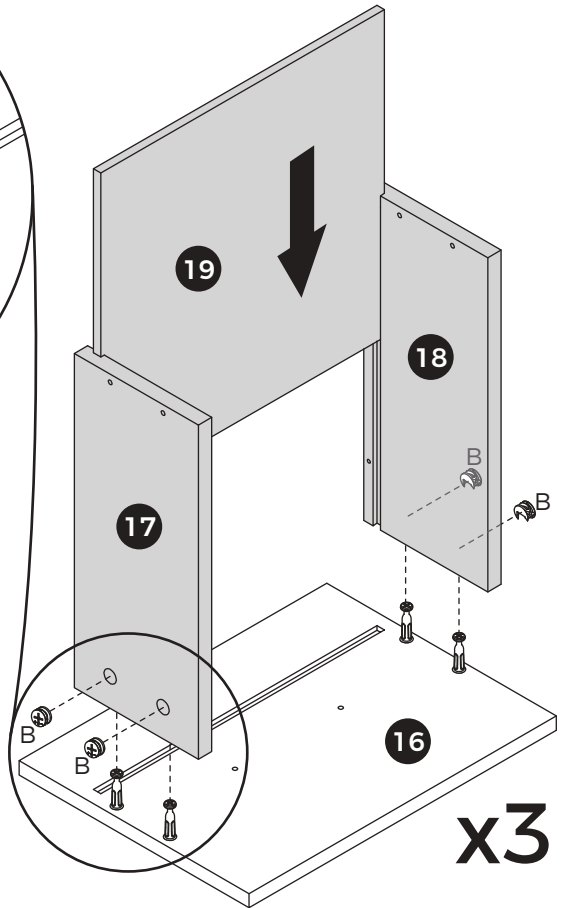
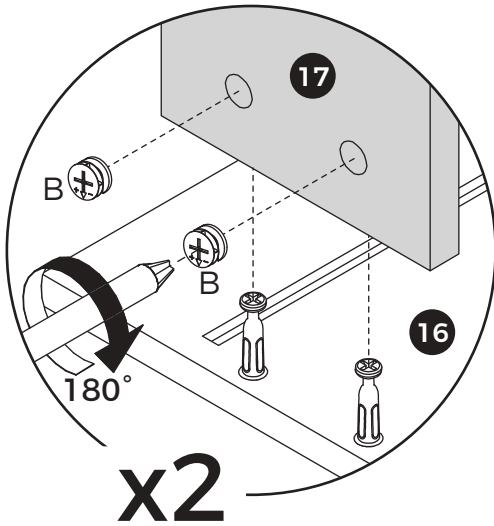

# 34



[EN] Secure panel 20 to panels 17 and 18 using screw (D).

[ES] Fije el panel 29 a los paneles 17 y 18 utilizando el tornillo (D).

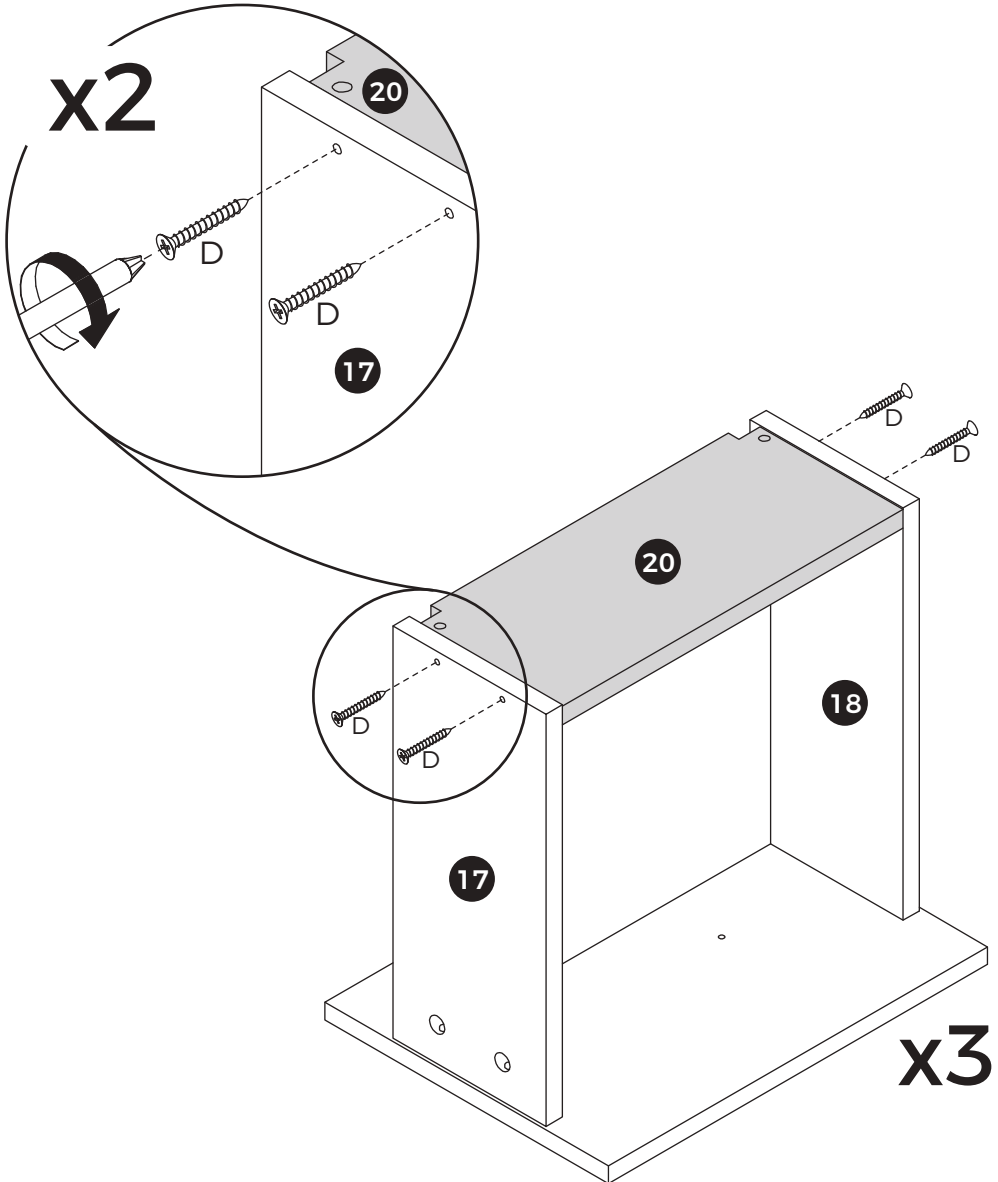

# 35



[EN] Secure handle (G) to panel 16 using screw (F).

[ES] Fije la manija (G) al panel 16 utilizando el tornillo (F).

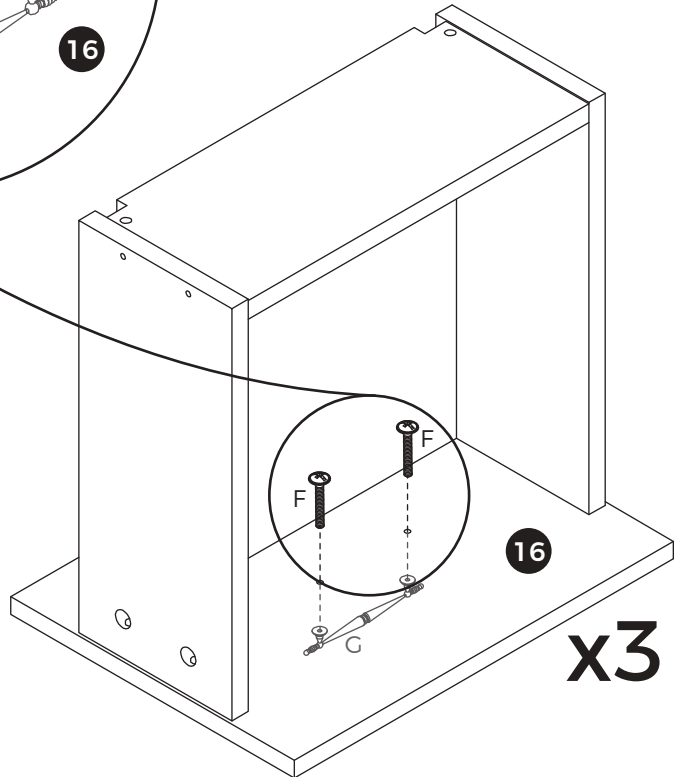
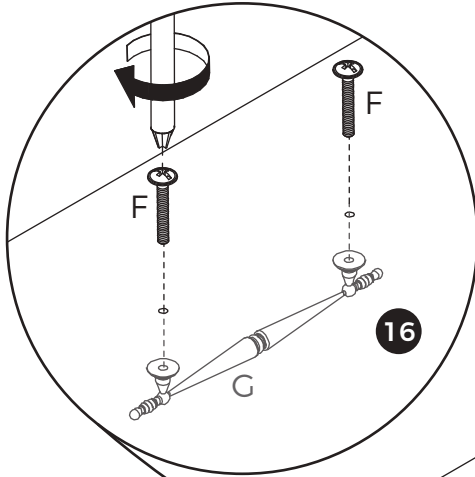

# 36



[EN] Secure hinge (H) to door panels 21 and 22 with screw (E).

[ES] Fije la bisagra (H) a los paneles de la puerta 21 y 22 con el tornillo (E).

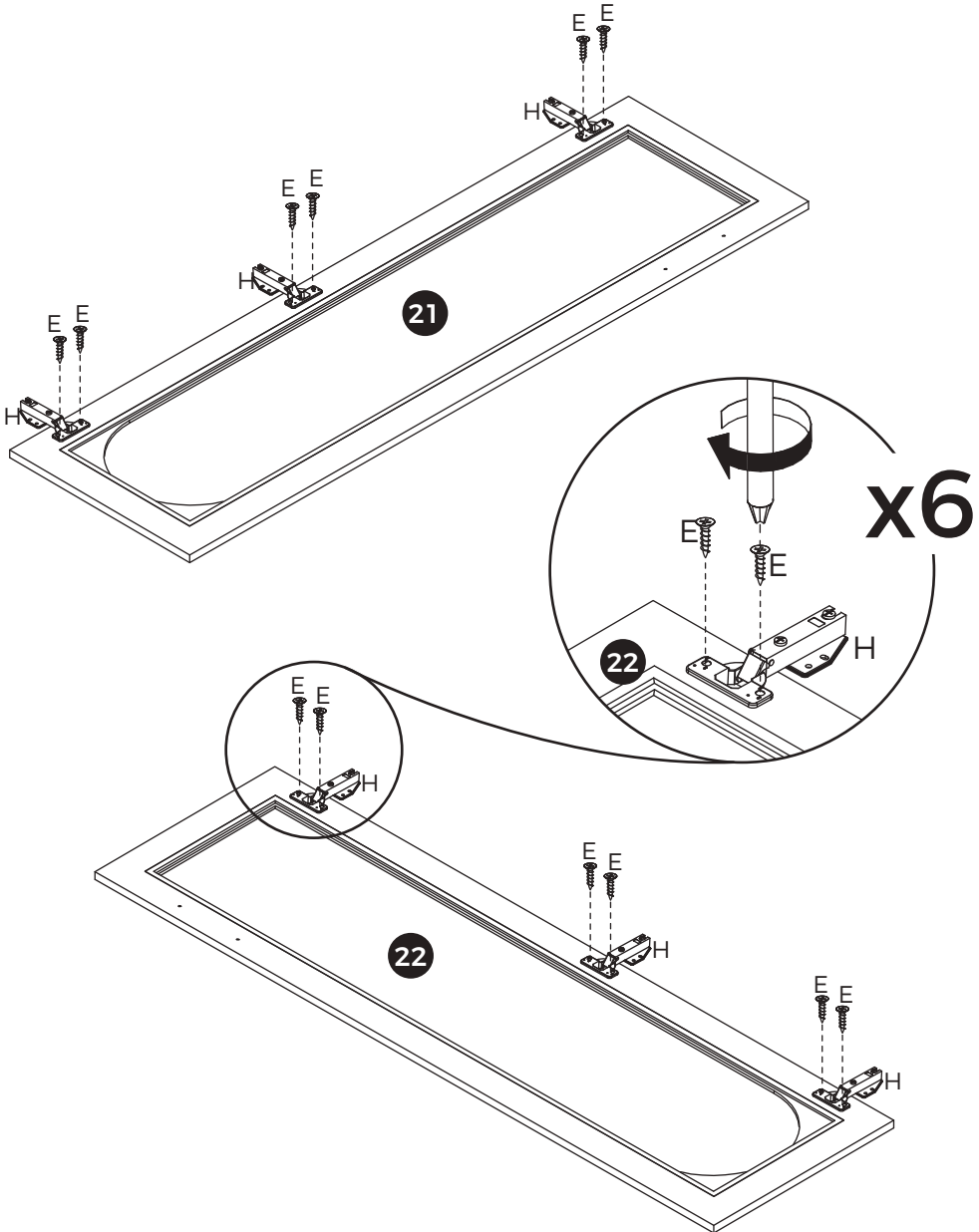

# 37



[EN] Mount the door panels to the unit using screw (E).

[ES] Monte los paneles de la puerta en la unidad utilizando el tornillo (E).

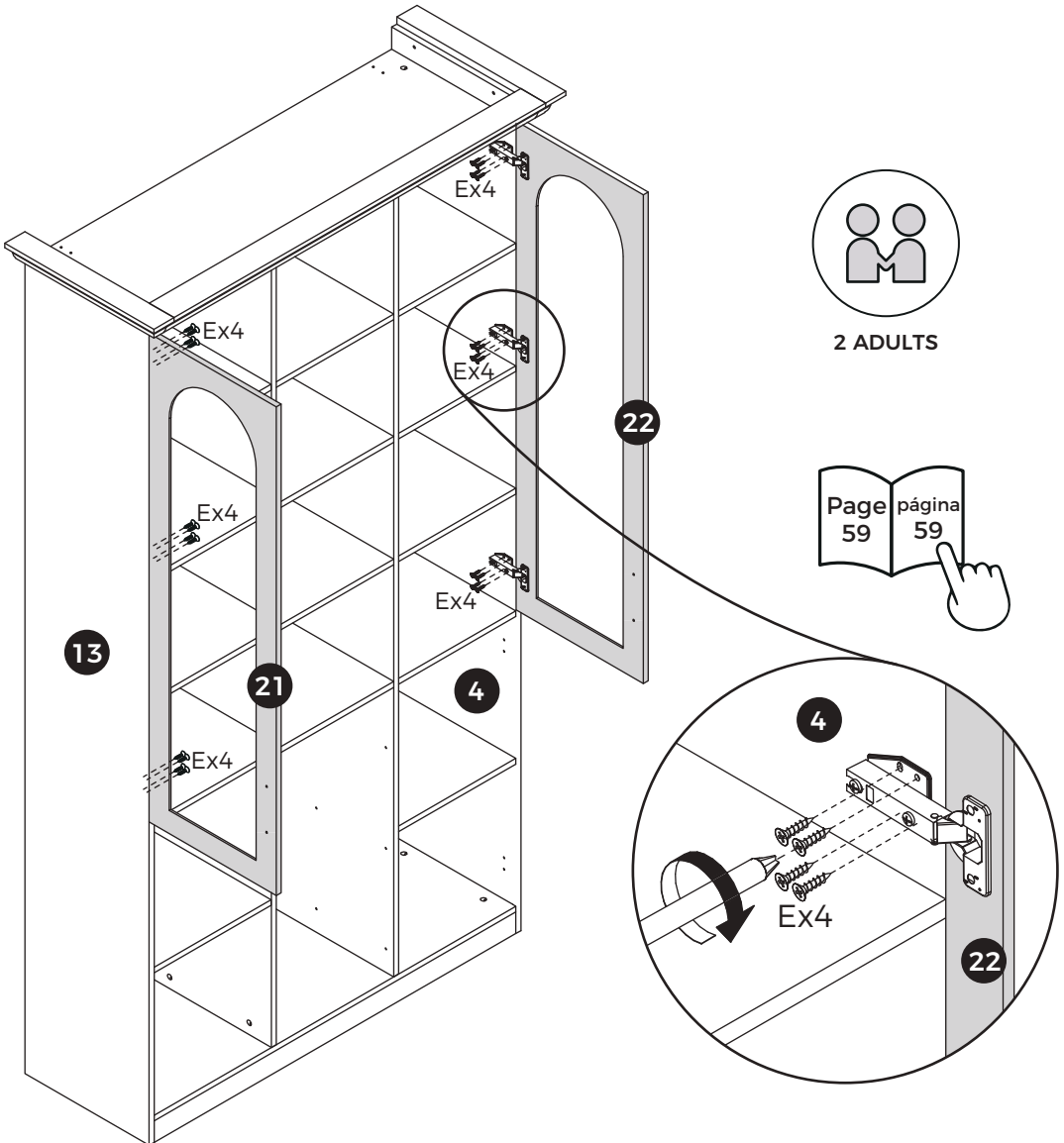

# 38



[EN] Secure hinge (H) to door panels 23 and 24 using screw (E).

[ES] Fije la bisagra (H) a los paneles de la puerta 23 y 24 utilizando el tornillo (E).

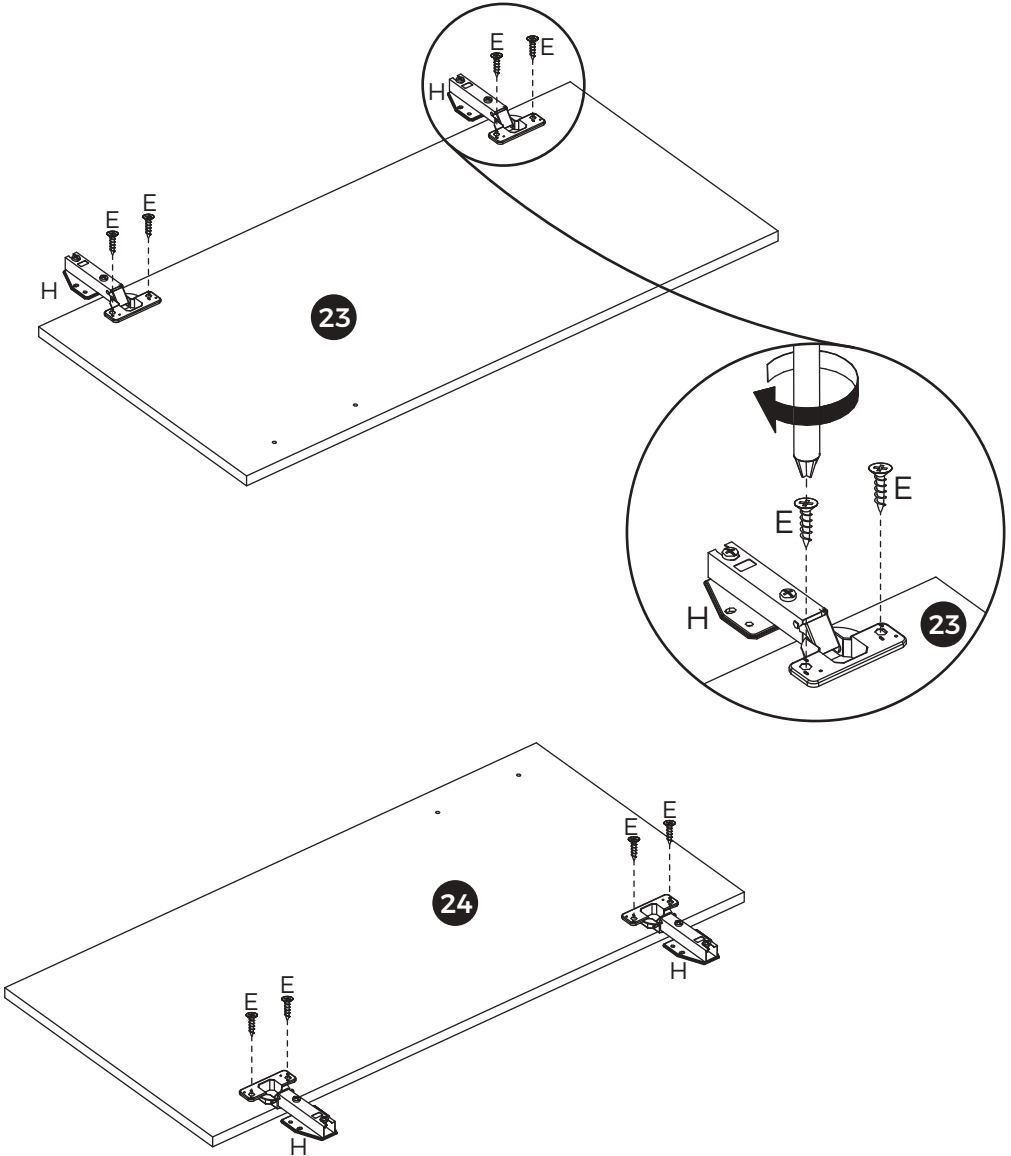

# 39



[EN] Mount the door panels to the unit using screw (E).

[ES] Monte los paneles de la puerta en la unidad utilizando el tornillo (E).

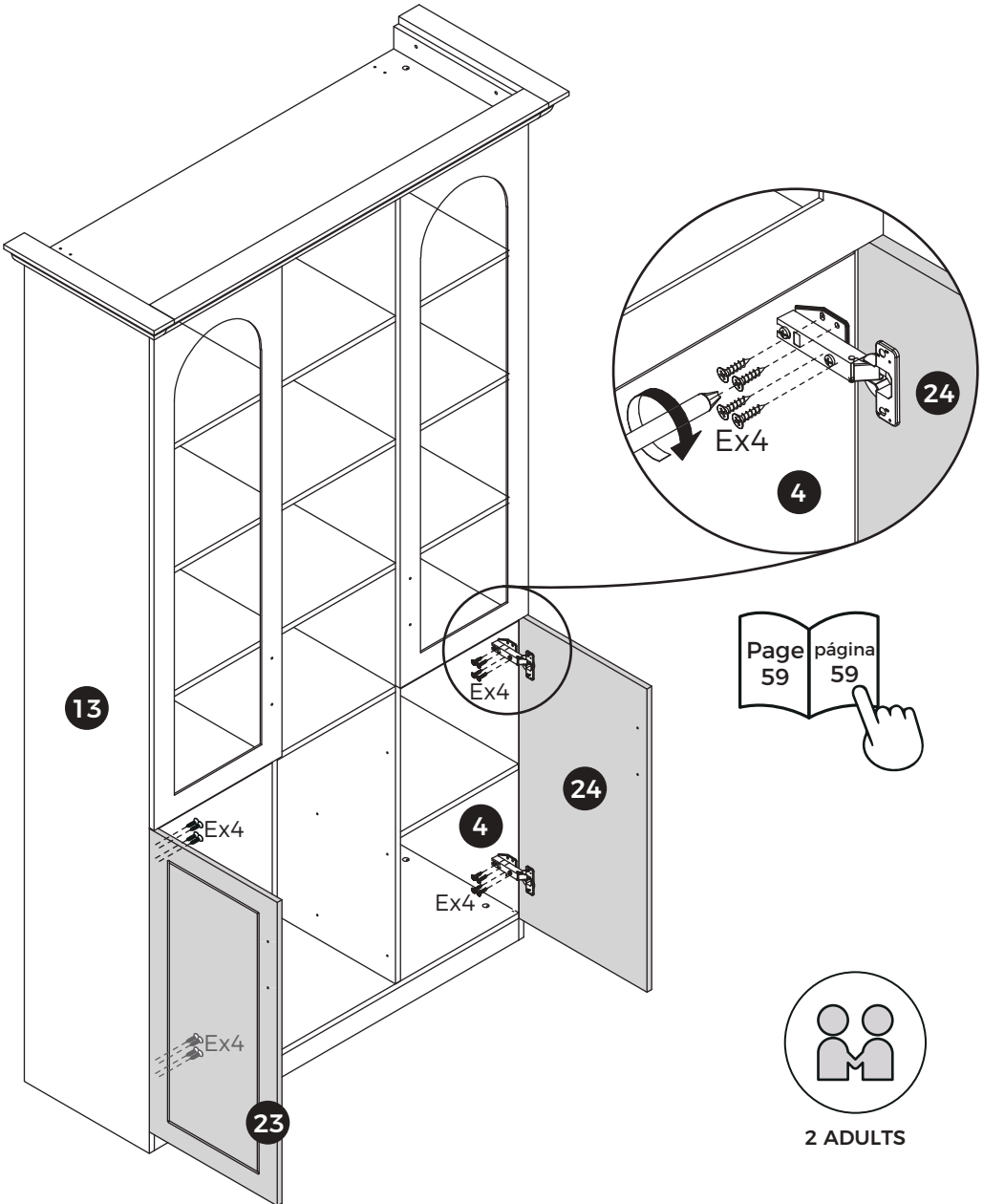

# 40



[EN] Secure handle (G) to door panels using screw (F).

[ES] Fije la manija (G) a los paneles de la puerta utilizando el tornillo (F).

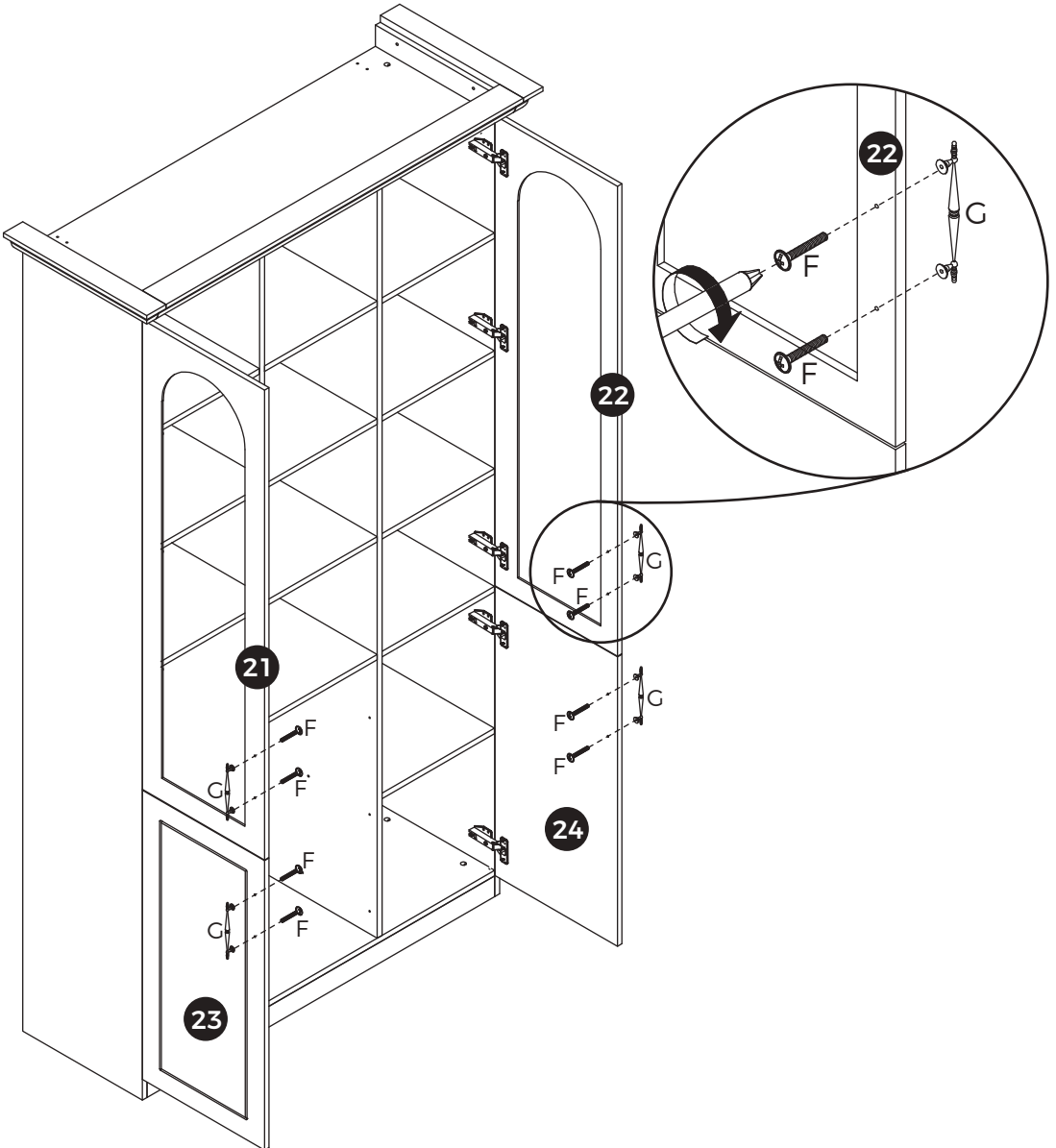

# 41

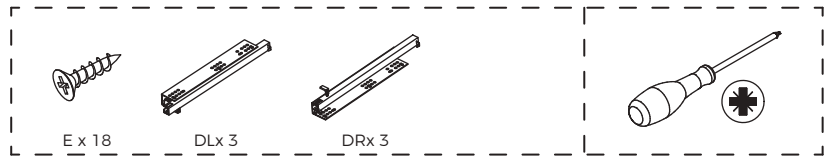

[EN] Secure slide rails (DL) and (DR) to panels 7 and 8 respectively using screw (E).

[ES] Fije los rieles deslizantes (DL) y (DR) a los paneles 7 y 9 respectivamente utilizando el tornillo (E).

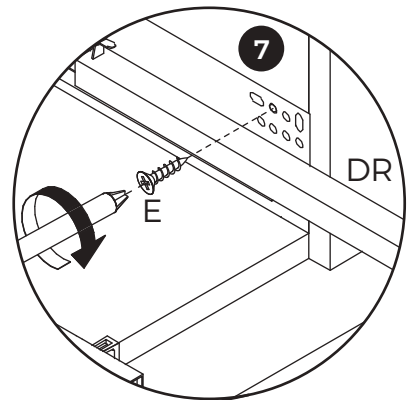
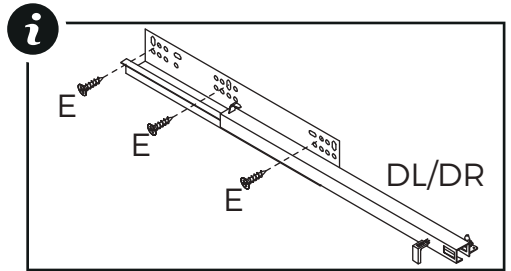
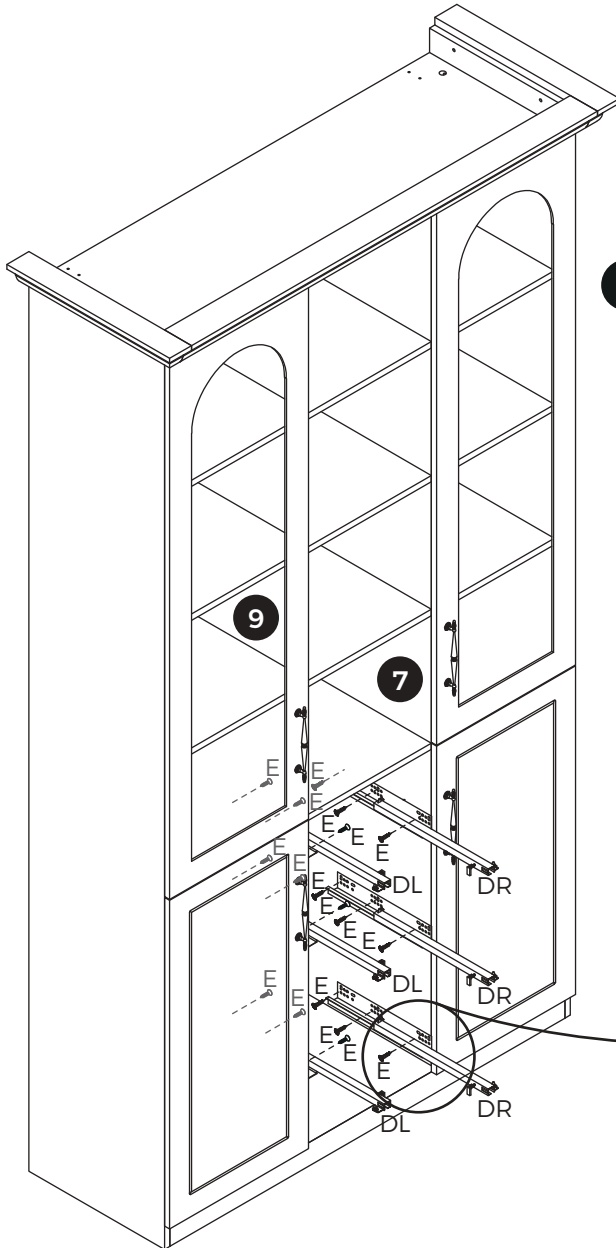

2 ADULTS

# 42

[EN] Install the drawers by fitting the protrusions on the slide rails into the holes in the drawers.

[ES] Instale los cajones encajando las protuberancias de los rieles deslizantes en los orificios de los cajones.

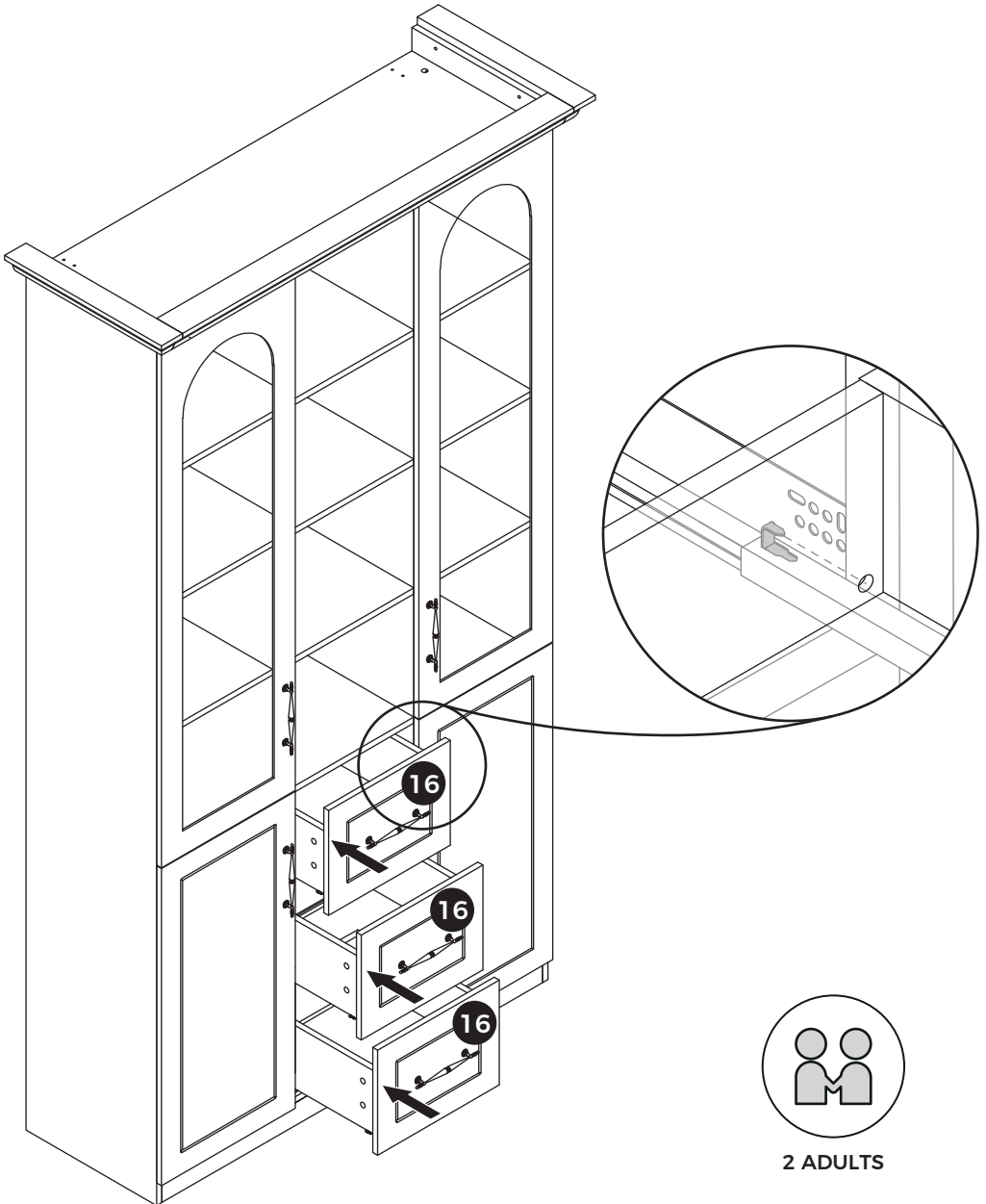

# 43

[EN] Align with the holes, then lock the slide rail clips in place.

[ES] Alinee con los orificios y luego bloquee los clips del riel deslizante en su lugar.

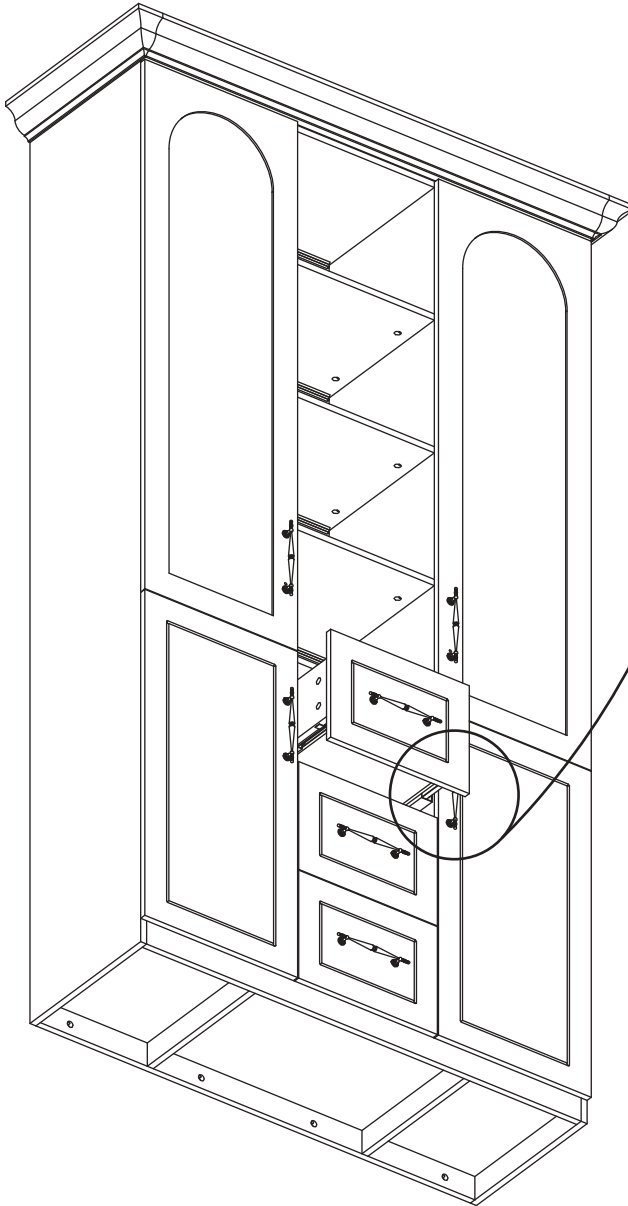

2 ADULTS

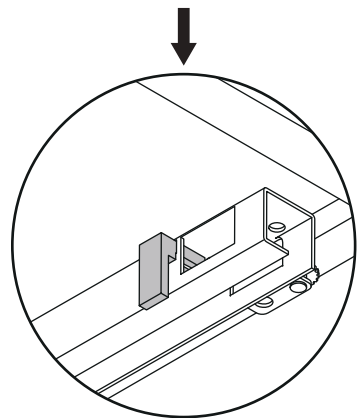
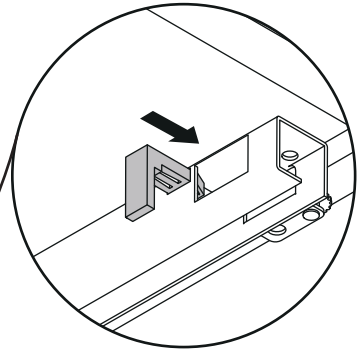

[EN] After installing the drawers, rotate the knob to adjust the height if misalignment occurs.

[ES] Después de instalar los cajones, gire la perilla para ajustar la altura si hay desalineación.

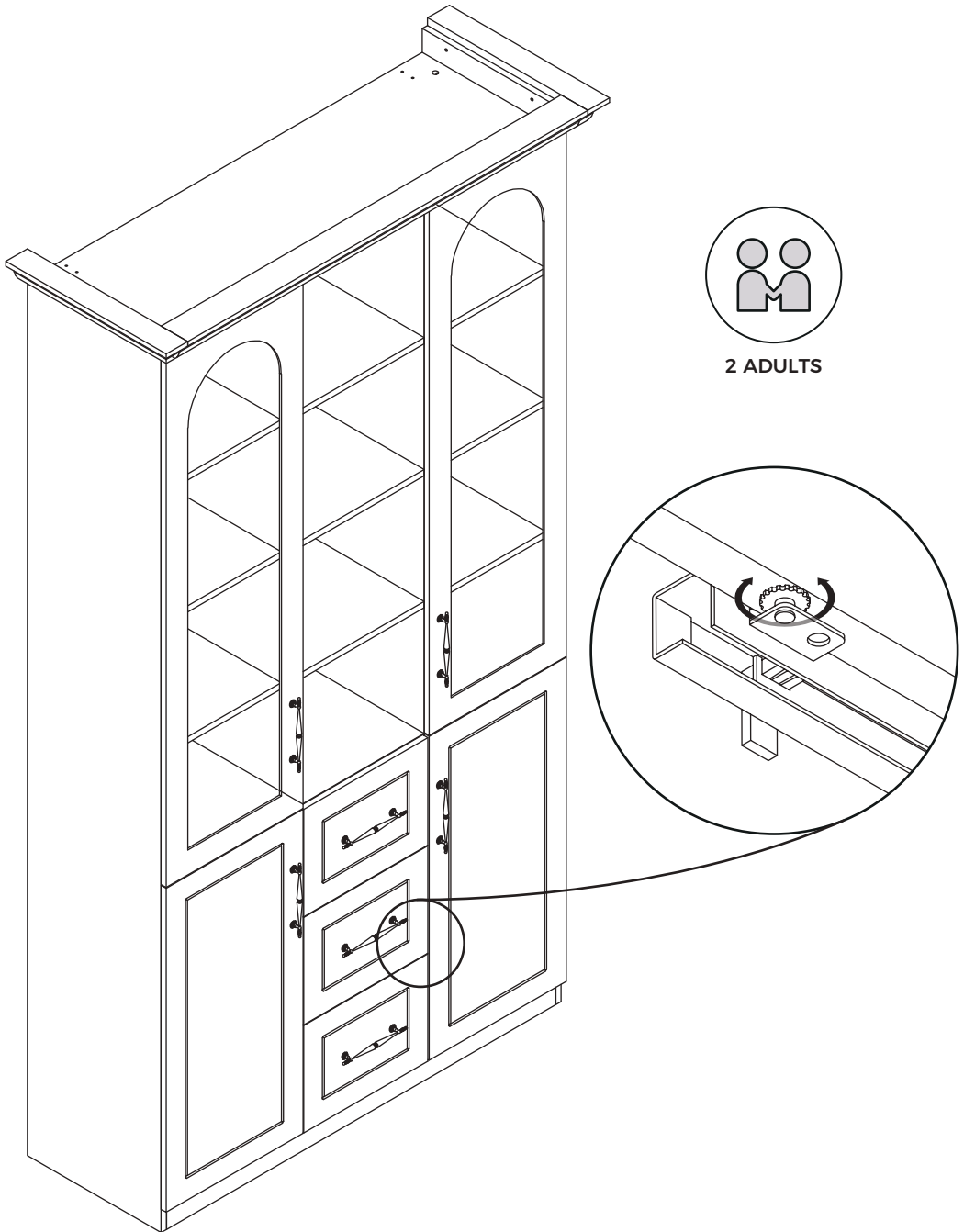



# 46

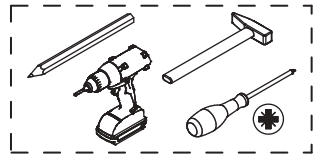
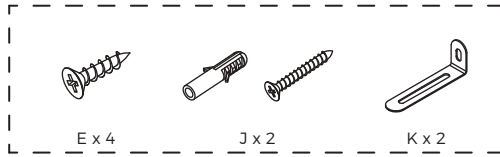

[EN] Install anti-tipping device as shown.

[ES] Instale el dispositivo antivuelco como se muestra.

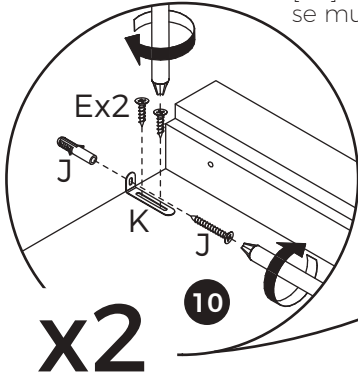

x2

10

10

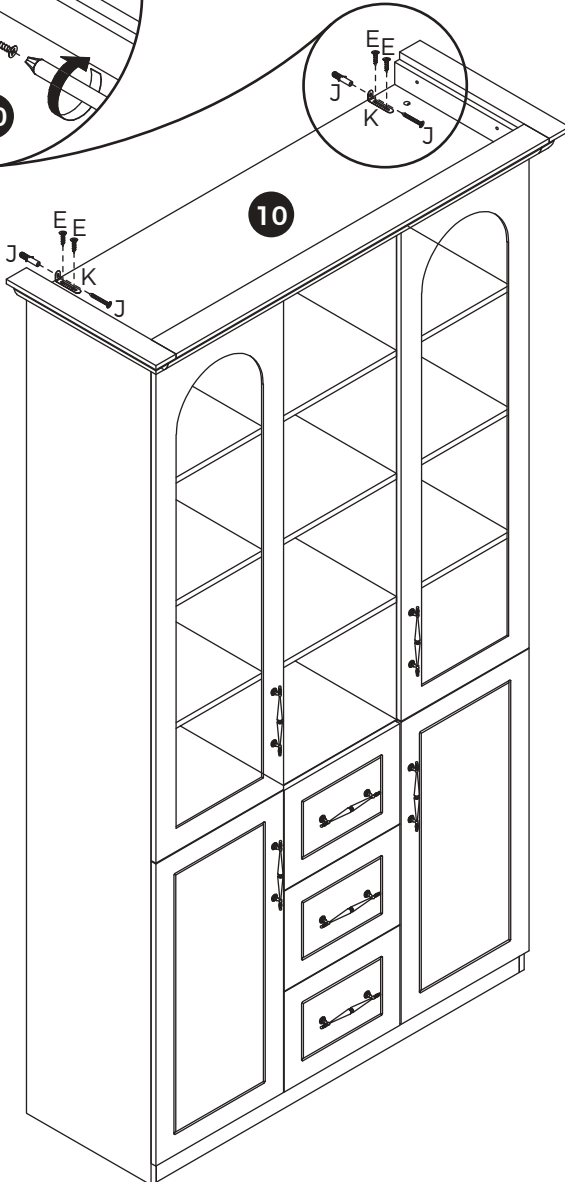

1.

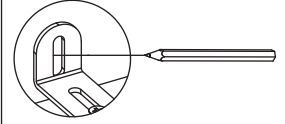

2.

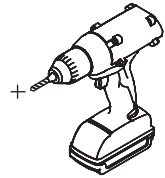

3.

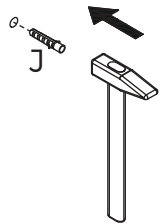

4.

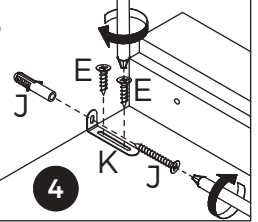

4



2 ADULTS

# 47

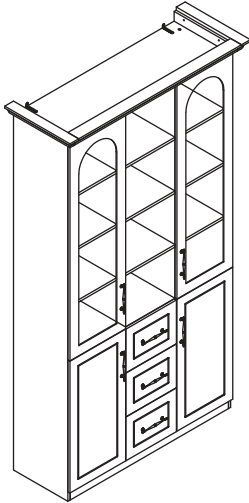
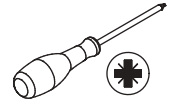

[EN] If the door panels are not aligned after installation, adjust the hinge screws as needed. Refer to the instructions and video link.

[ES] Si los paneles de la puerta no están alineados después de la instalación, ajuste los tornillos de la bisagra según sea necesario. Consulte las instrucciones y el enlace del video.

<https://youtu.be/n0Lb36SoODM>

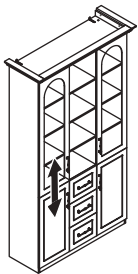

①

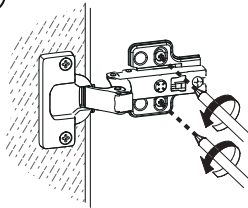

②

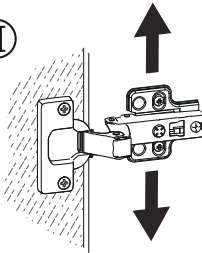

③

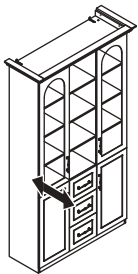
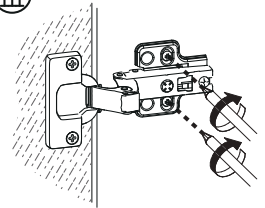

①

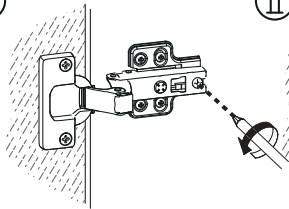

②

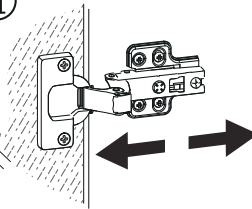

③

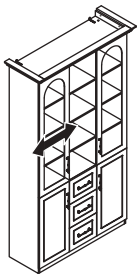
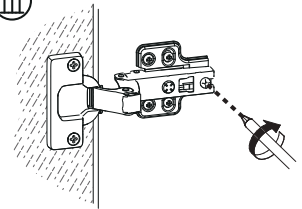

①

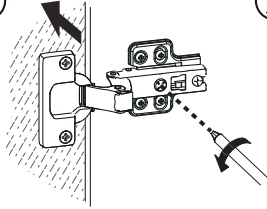

②

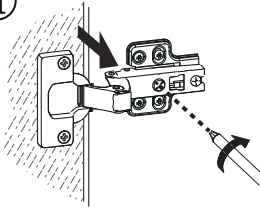

# 48

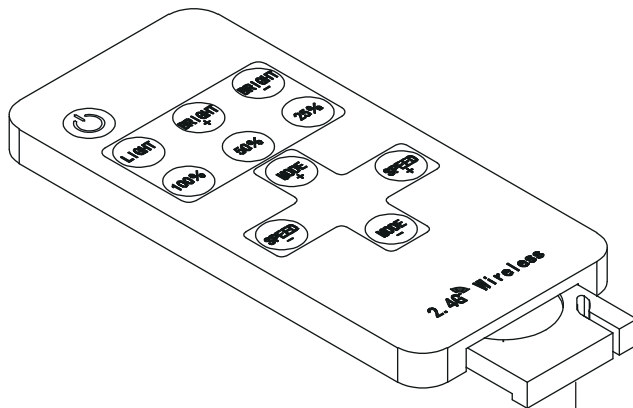
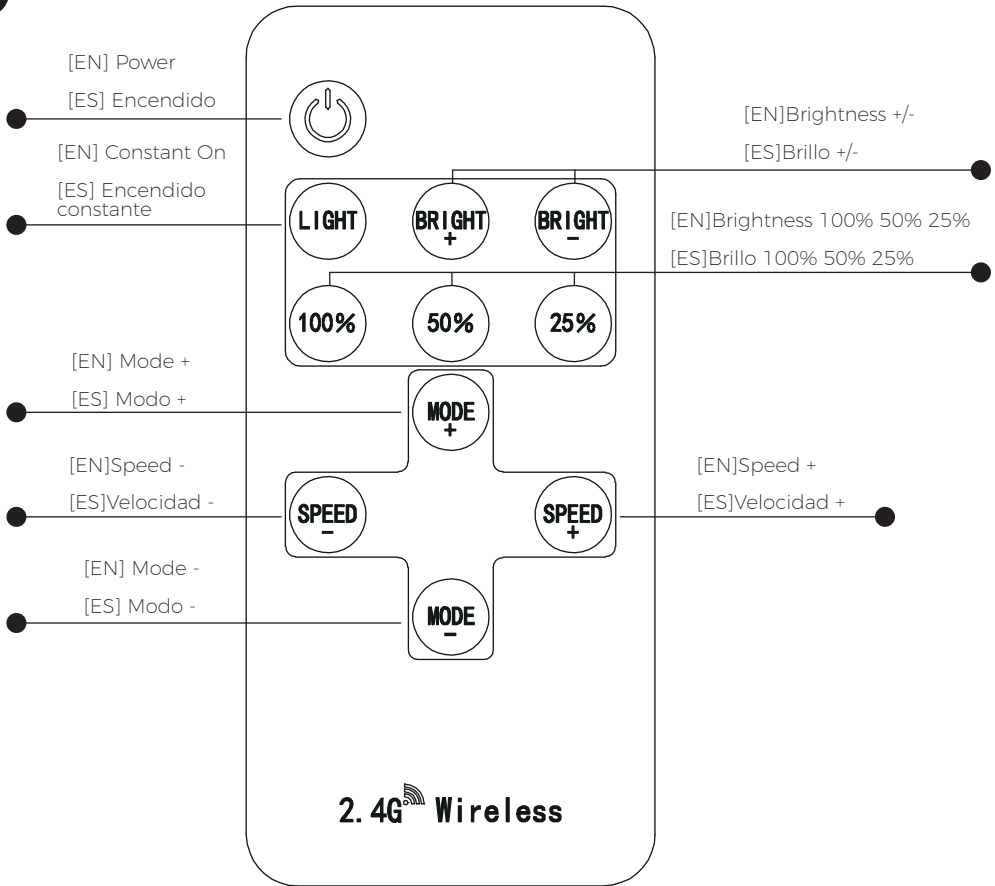

[EN] Requires 3V CR2025 button cell batteries.  
[ES] Requiere baterías tipo botón CR2025 de 3 V.



Should you have any problems assembling your product, contact us at **customerservice@homsee.com**. We're always happy to help! We have carefully selected the materials used in this product, and ask you to treat it responsibly too. Please recycle all packaging according to your local disposal rules.

Si tienes algún problema al ensamblar tu producto, contáctanos a **customerservice@homsee.com**. Siempre estaremos encantados de ayudarte. Hemos seleccionado cuidadosamente los materiales utilizados en este producto y te pedimos que también lo trates de manera responsable. Por favor, recicla todo el embalaje de acuerdo con las normas locales de eliminación de residuos.

