



ASSEMBLY INSTRUCTIONS



One of the unique features of Homsee furniture is its versatility. Designed with the idea of customization in mind, our products can be easily linked together to create seamless, personalized setups that fit your specific needs.

For instance, if you purchase a couple of our shelves, you can effortlessly combine them to form a larger, unified structure. This modular approach allows you to expand, rearrange, and adapt your furniture as your space and style evolve. Whether you're looking to create a vast shelving system, or a continuous storage solution, the possibilities are endless.

At Homsee, we empower you to create a space that is truly yours—one that grows with you, all while maintaining a sleek, cohesive look.



Una de las características distintivas del mobiliario Homsee es su versatilidad. Diseñados pensando en la personalización, nuestros productos pueden conectarse fácilmente entre sí para crear configuraciones continuas y personalizadas que se ajusten a tus necesidades específicas.

Por ejemplo, si compras un par de nuestras estanterías, puedes combinarlas sin esfuerzo para formar una estructura más grande y unificada. Este enfoque modular te permite ampliar, reorganizar y adaptar tus muebles a medida que evolucionan tu espacio y tu estilo. Ya sea que busques crear un amplio sistema de estanterías o una solución de almacenamiento continua, las posibilidades son infinitas.

En Homsee, te ayudamos a crear un espacio verdaderamente tuyo—uno que crece contigo, manteniendo a la vez un aspecto elegante y coherente.



IMPORTANT INFORMATION!

Please read the entire manual before starting to assembling or using this product. Follow the manual thoroughly and keep it for further reference.

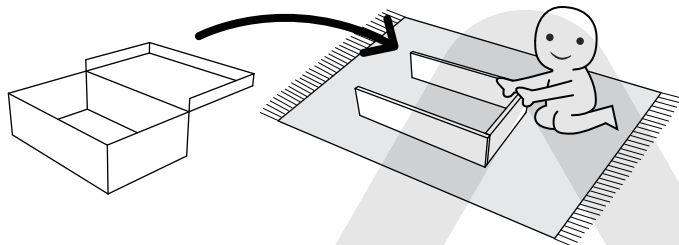

AVOID SCRATCHES!

In order to avoid scratching the furniture should be assembled on a soft layer—could be a rug.

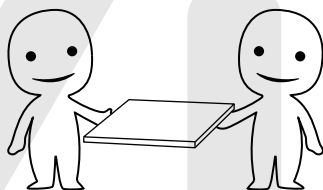

IMPROVE ASSEMBLY EFFICIENCY !

Try to find a partner to install with you, which can speed up the installation efficiency and shorten the time.

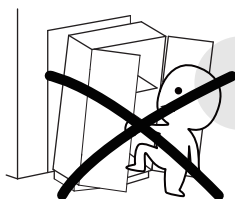
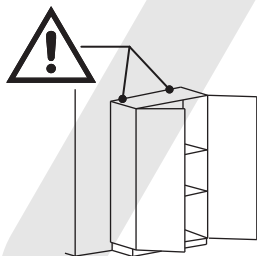

ANTI-TOPPLE WARNING !

Overturned furniture can cause serious or fatal crush injuries. To prevent tipping, be sure to use a wall-anchoring attachment. If one is not included with this product, please purchase a suitable attachment that fits your wall. If unsure, seek professional advice. Please read and follow all instructions carefully.

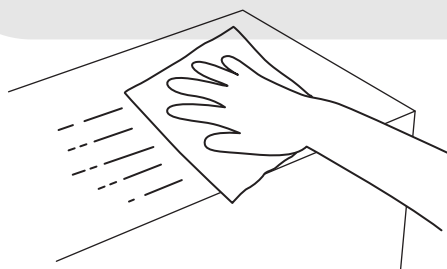

MAINTENANCE AND CLEANING !

For regular maintenance and cleaning, use a rag dipped in neutral detergent to wipe the frame thoroughly, and then dry it with a clean rag. For glass surfaces, wipe with a rag dampened with water or glass cleaner, and then dry with a clean, dry cloth.



¡INFORMACIÓN IMPORTANTE!

Por favor, lee todo el manual antes de comenzar a ensamblar o usar este producto. Sigue las instrucciones detenidamente y consérvalo para futuras consultas.

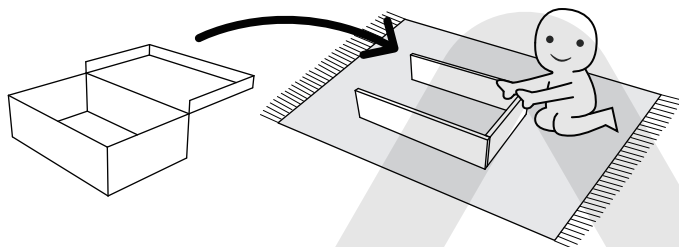

¡EVITA LOS RAYONES!

Para evitar que el mueble se raye, debe ensamblarse sobre una superficie suave, como una alfombra.

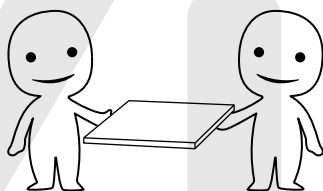

¡MEJORA LA EFICIENCIA!

Intenta encontrar a alguien que te ayude con la instalación; trabajar en pareja puede aumentar la eficiencia y reducir el tiempo de montaje.

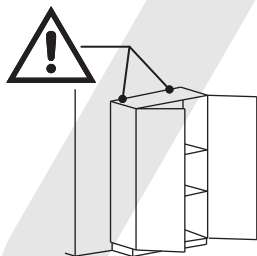

¡ADVERTENCIA ANTIVUELCO!

El mobiliario volcado puede causar lesiones graves o incluso mortales por aplastamiento. Para evitar que se vuelque, asegúrate de utilizar el sistema de anclaje a la pared. Si este producto no lo incluye, adquiere un anclaje compatible con tu pared. Si no estás seguro de cuál usar, busca asesoramiento profesional. Lee y sigue cuidadosamente cada paso de las instrucciones.

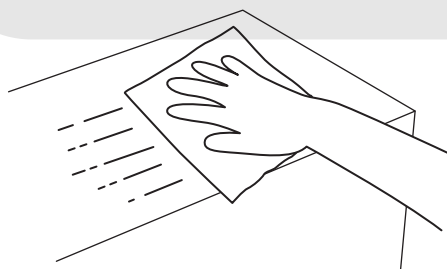

¡MANTENIMIENTO Y LIMPIEZA!

Para el mantenimiento y la limpieza regulares del producto, limpia el marco con un paño humedecido en un detergente neutro y luego sécalo con un paño limpio. Para los materiales de vidrio, límpialos con un paño humedecido en limpiador de vidrios con agua y luego sécalos con un paño seco.



The following are common installation steps. Correct operation is required to avoid product damage.

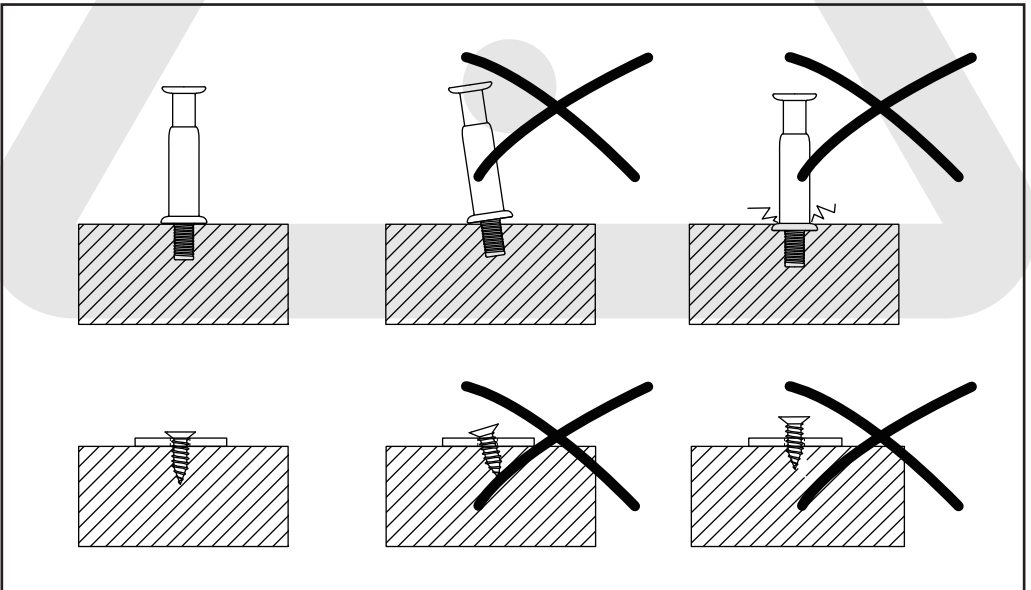
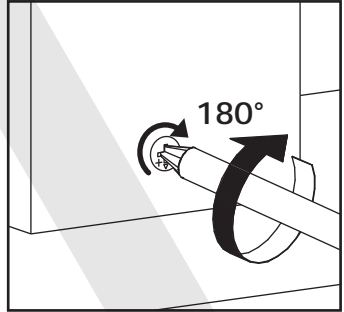
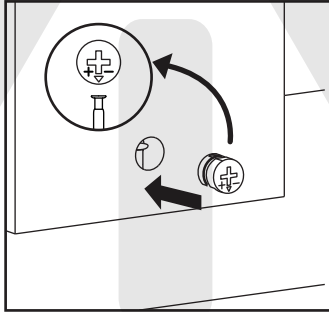
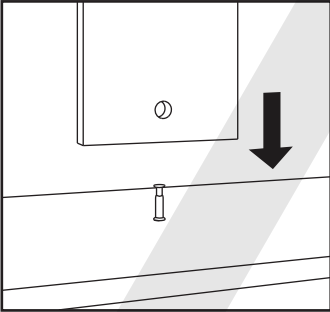
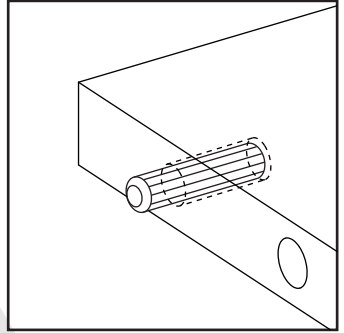
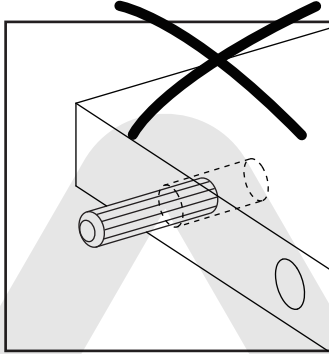
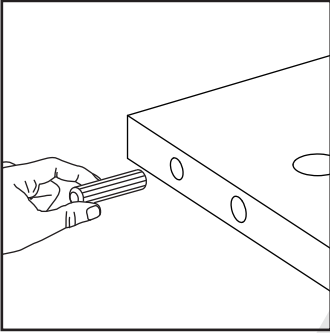



Los siguientes pasos de instalación son bastante comunes y requieren una operación correcta durante el proceso de montaje. El uso incorrecto puede dañar el mueble.

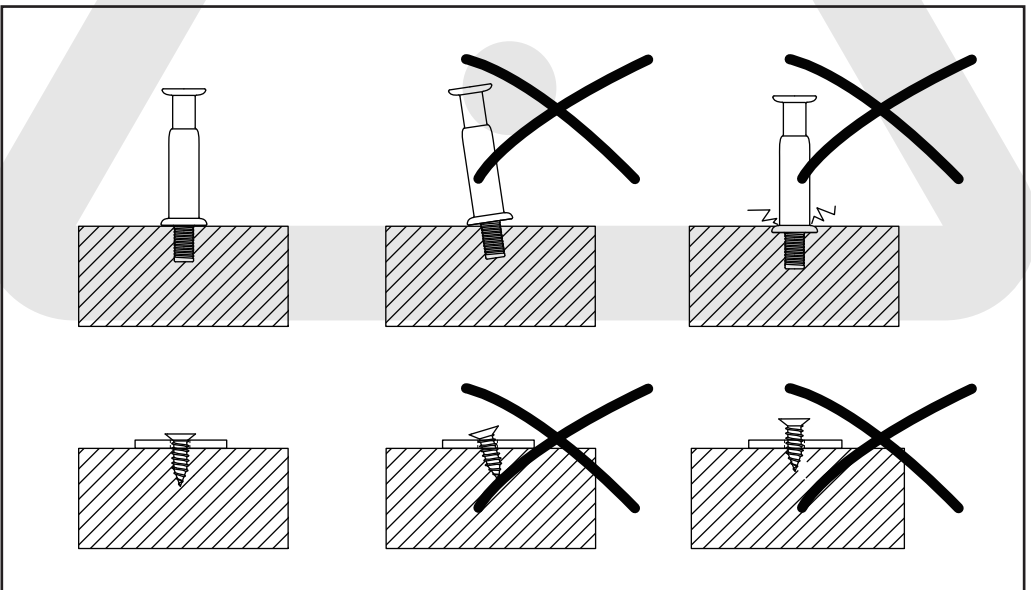
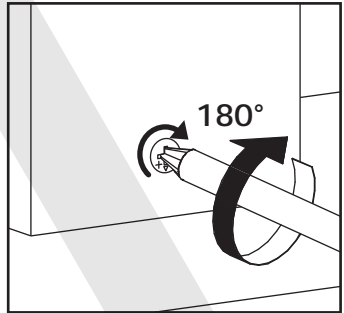
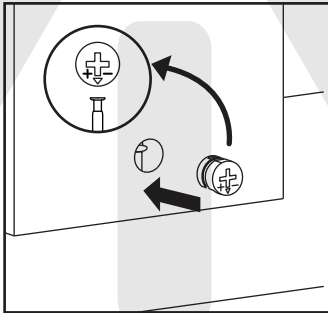
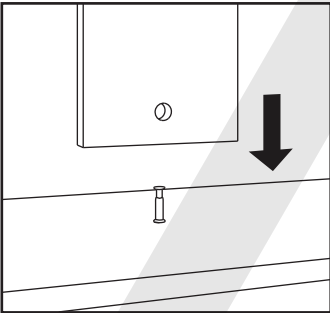
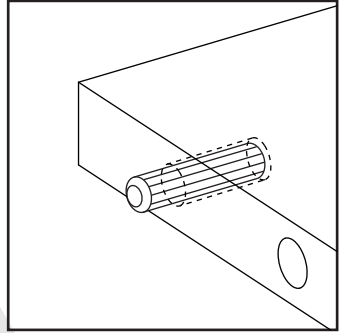
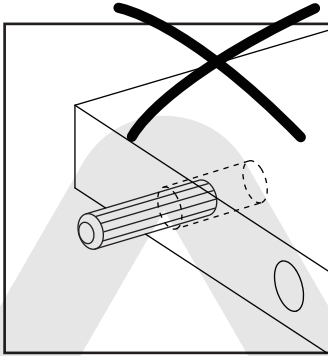
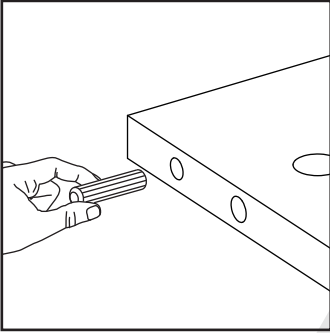



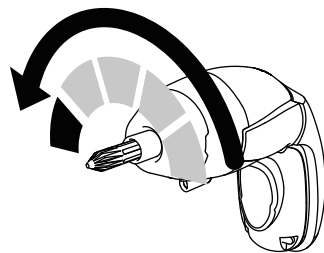
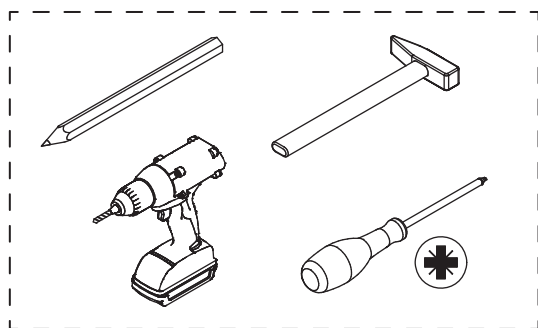



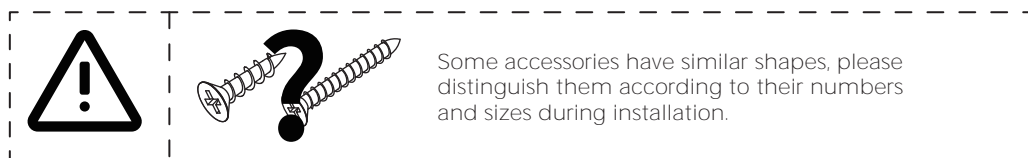



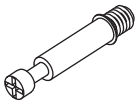

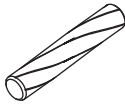

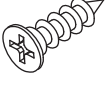
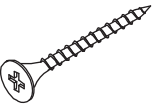

Please prepare the following tools

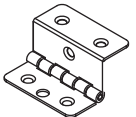
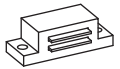

If you choose to use power tools, set them to a low-power setting. Use caution—power tools may crack or damage the furniture and can also harm the hardware.

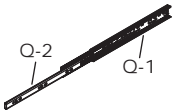

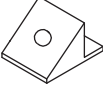
Some accessories have similar shapes, please distinguish them according to their numbers and sizes during installation.

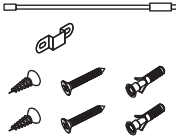
<p>A x 56</p>  <p>Ø6 x 40 mm</p>	<p>B x 56</p>  <p>Ø15 x 12 mm</p>	<p>C x 5</p>  <p>Ø4 x 25 mm</p>	<p>D x 50</p>  <p>Ø3 x 12 mm</p>	<p>E x 28</p>  <p>Ø3 x 14 mm</p>
<p>F x 10</p>  <p>Ø3.5 x 25 mm</p>	<p>G x 2</p>  <p>Ø4 x 16 mm</p>	<p>H x 2</p>  <p>Ø4 x 22 mm</p>	<p>J x 4</p> 	<p>K x 4</p> 
<p>L x 2</p> 	<p>M x 2</p> 	<p>N x 1</p> 	<p>O x 1</p> 	<p>P x 1</p> 
<p>Q x 4</p>  <p>Q-2 Q-1</p>	<p>R x 8</p> 	<p>S x 17</p> 	<p>T x 4</p> 	<p>U x 2</p> 

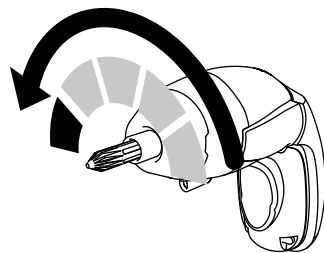
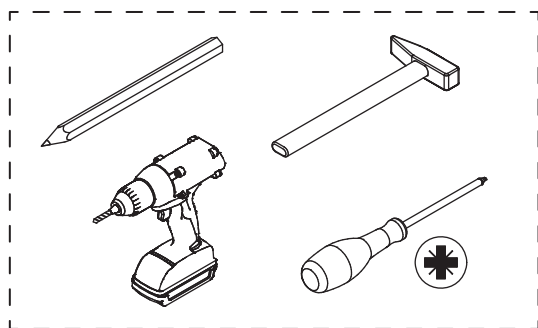

Please prepare the following tools

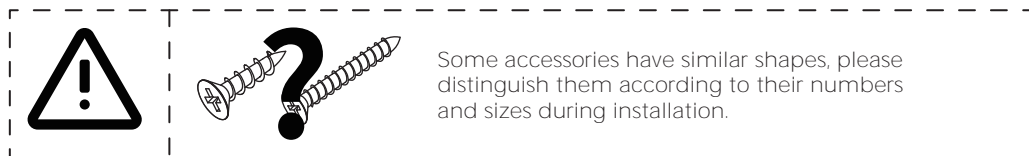

If you choose to use power tools, set them to a low-power setting. Use caution—power tools may crack or damage the furniture and can also harm the hardware.

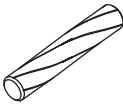
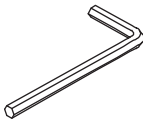

Some accessories have similar shapes, please distinguish them according to their numbers and sizes during installation.

V x 4	W x 3	Y x 2	Standby
	 Ø6 x 30 mm		



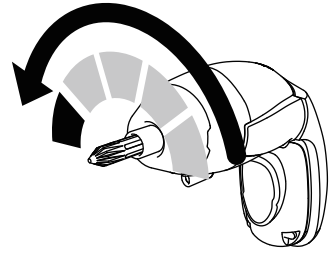
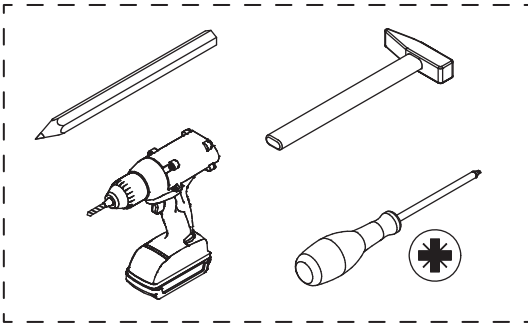







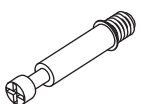

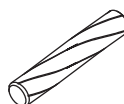

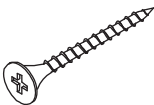

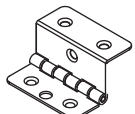

Por favor, prepara las siguientes herramientas



Si decides utilizar herramientas eléctricas, ajústalas a una velocidad baja. ¡Ten cuidado! Las herramientas eléctricas pueden causar grietas o daños en el mueble, y también pueden dañar los herrajes.

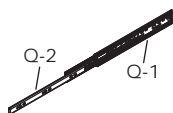

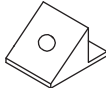
Algunos accesorios tienen la misma forma; por favor, distíngalos según sus números y tamaños durante la instalación.

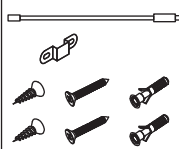
<p>A x 56</p>  <p>Ø6 x 40 mm</p>	<p>B x 56</p>  <p>Ø15 x 12 mm</p>	<p>C x 5</p>  <p>Ø4 x 25 mm</p>	<p>D x 50</p>  <p>Ø3 x 12 mm</p>	<p>E x 28</p>  <p>Ø3 x 14 mm</p>
<p>F x 10</p>  <p>Ø3.5 x 25 mm</p>	<p>G x 2</p>  <p>Ø4 x 16 mm</p>	<p>H x 2</p>  <p>Ø4 x 22 mm</p>	<p>J x 4</p> 	<p>K x 4</p> 
<p>L x 2</p> 	<p>M x 2</p> 	<p>N x 1</p> 	<p>O x 1</p> 	<p>P x 1</p> 
<p>Q x 4</p>  <p>Q-2 Q-1</p>	<p>R x 8</p> 	<p>S x 17</p> 	<p>T x 4</p> 	<p>U x 2</p> 

Por favor, prepara las siguientes herramientas

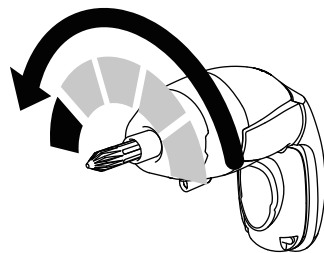
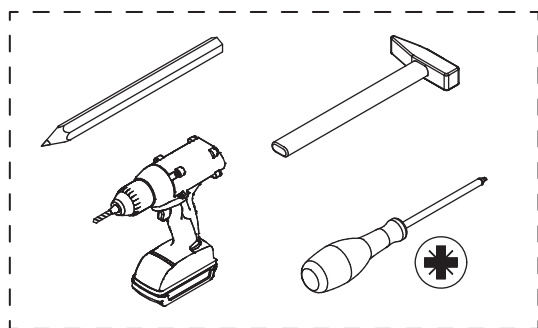

Si decides utilizar herramientas eléctricas, ajústalas a una velocidad baja. ¡Ten cuidado! Las herramientas eléctricas pueden causar grietas o daños en el mueble, y también pueden dañar los herrajes.



Algunos accesorios tienen la misma forma; por favor, distíngalos según sus números y tamaños durante la instalación.

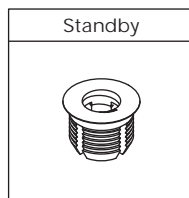
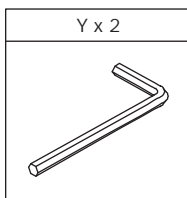
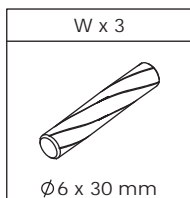
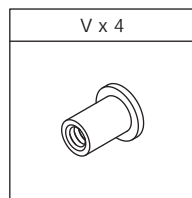

Parts List

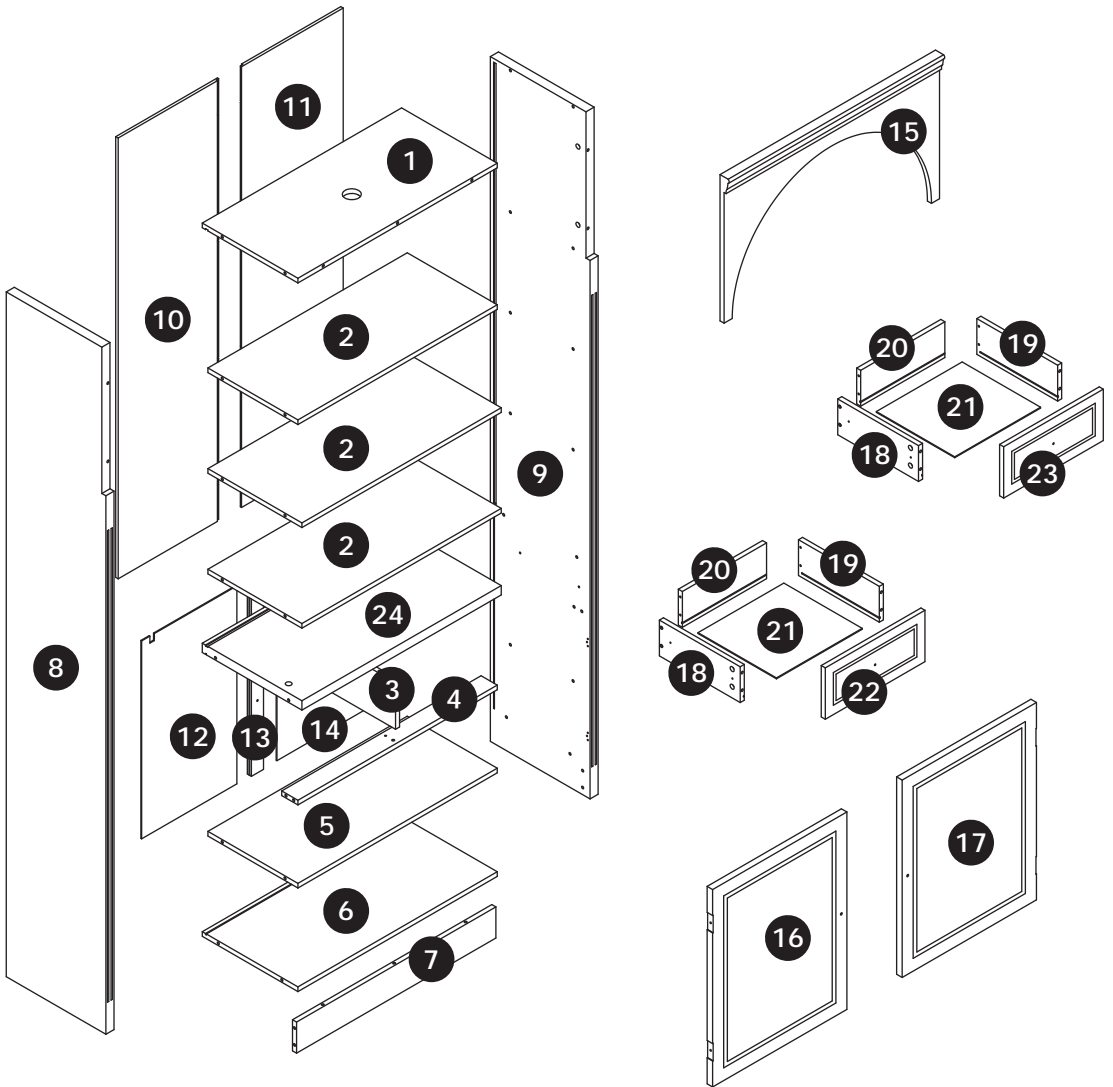

⚠ WARNING

Children have died from furniture tipover. To reduce the risk of furniture tipover:

- ALWAYS install Anti-tip device provided
- NEVER put a TV on this product.
- NEVER allow children to stand, climb or hang on drawers, doors, or shelves.
- NEVER open more than one drawer at a time.
- Place heaviest items in the lowest drawers.

This is a permanent label. Do not remove!



90 MINUTES



3 ADULTS



INTERMEDIATE

The parts listed above are required for proper assembly. If there are any issues. Contact us: customerservice@homsee.com

Lista de Piezas

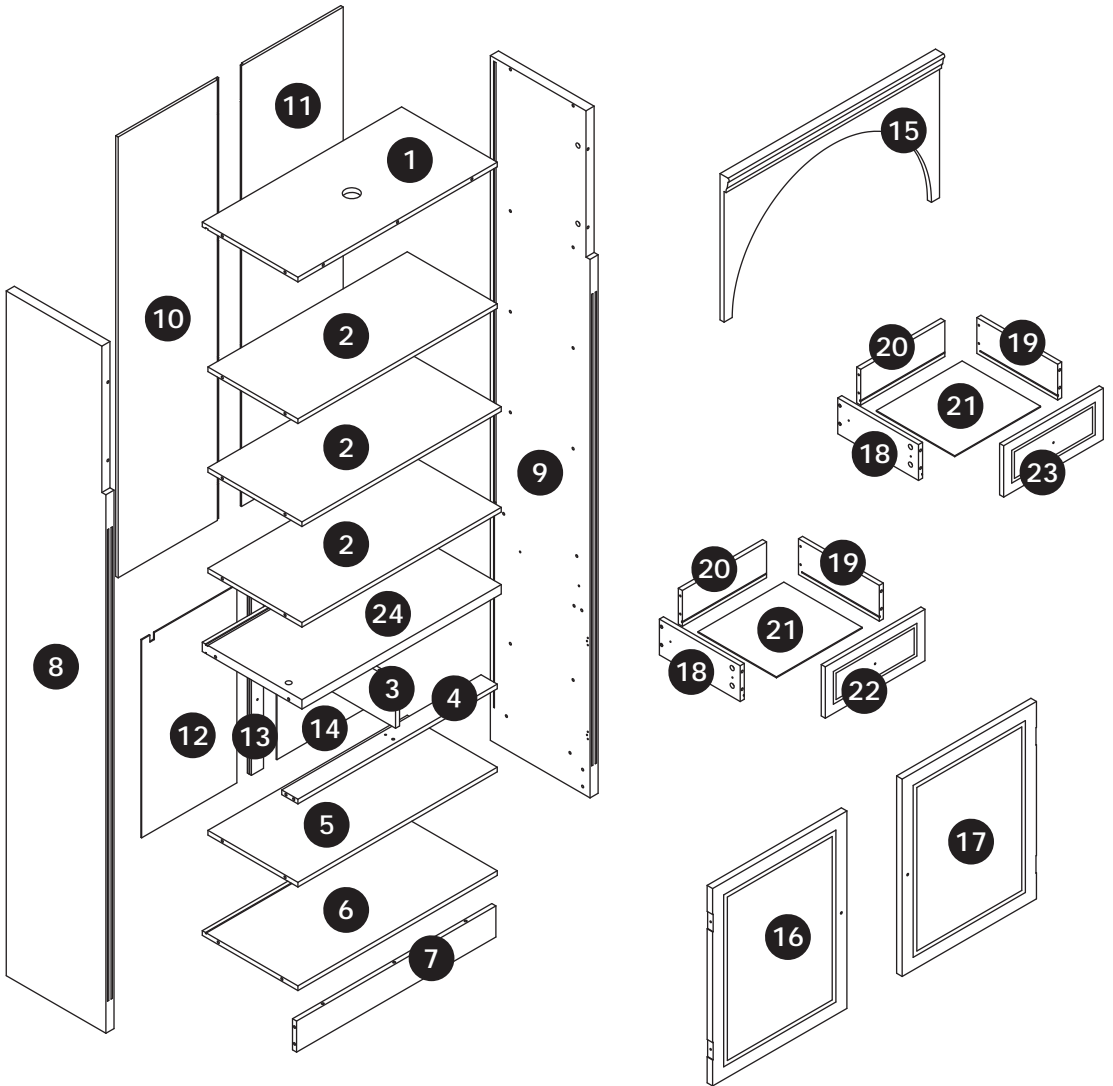

⚠ ADVERTENCIA

Los niños han muerto por el vuelco de muebles. Para reducir el riesgo de que el mueble se vuelque:

- SIEMPRE instala el dispositivo antivuelco incluido.
- NUNCA coloques un televisor sobre este producto.
- NUNCA permitas que los niños se suban, trepen o cuelguen de los cajones, puertas o estantes.
- NUNCA abras más de un cajón a la vez.
- Coloca los objetos más pesados en los cajones inferiores.

Esta es una etiqueta permanente.
¡No la retires!



90 MINUTOS



3 ADULTOS



INTERMEDIO

Las piezas enumeradas arriba son necesarias para un montaje correcto. Si tienes algún problema, contáctanos en: customerservice@homsee.com

01



[EN] Separate the glide into two parts first.

[ES] Separe la guía en dos partes primero.

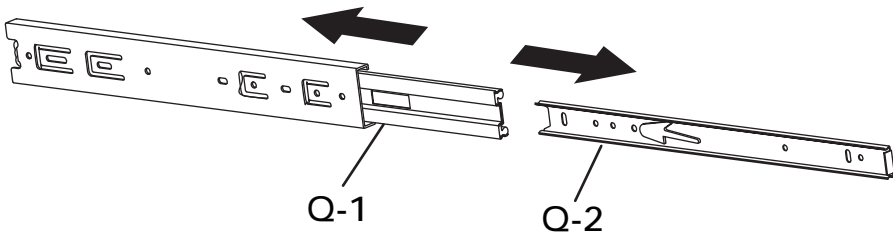
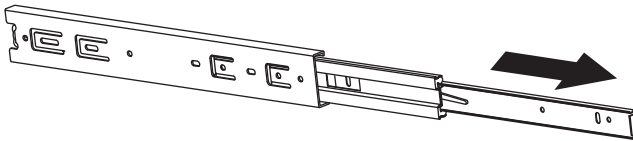
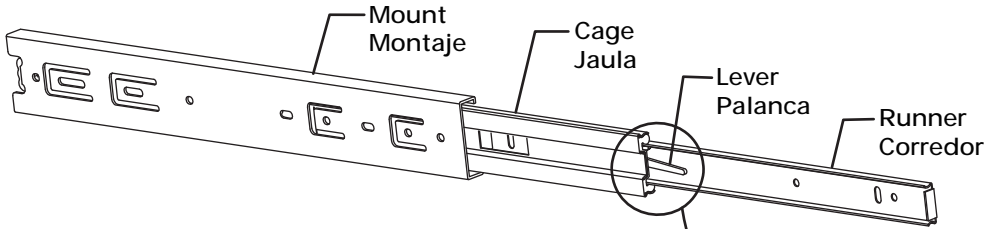

02

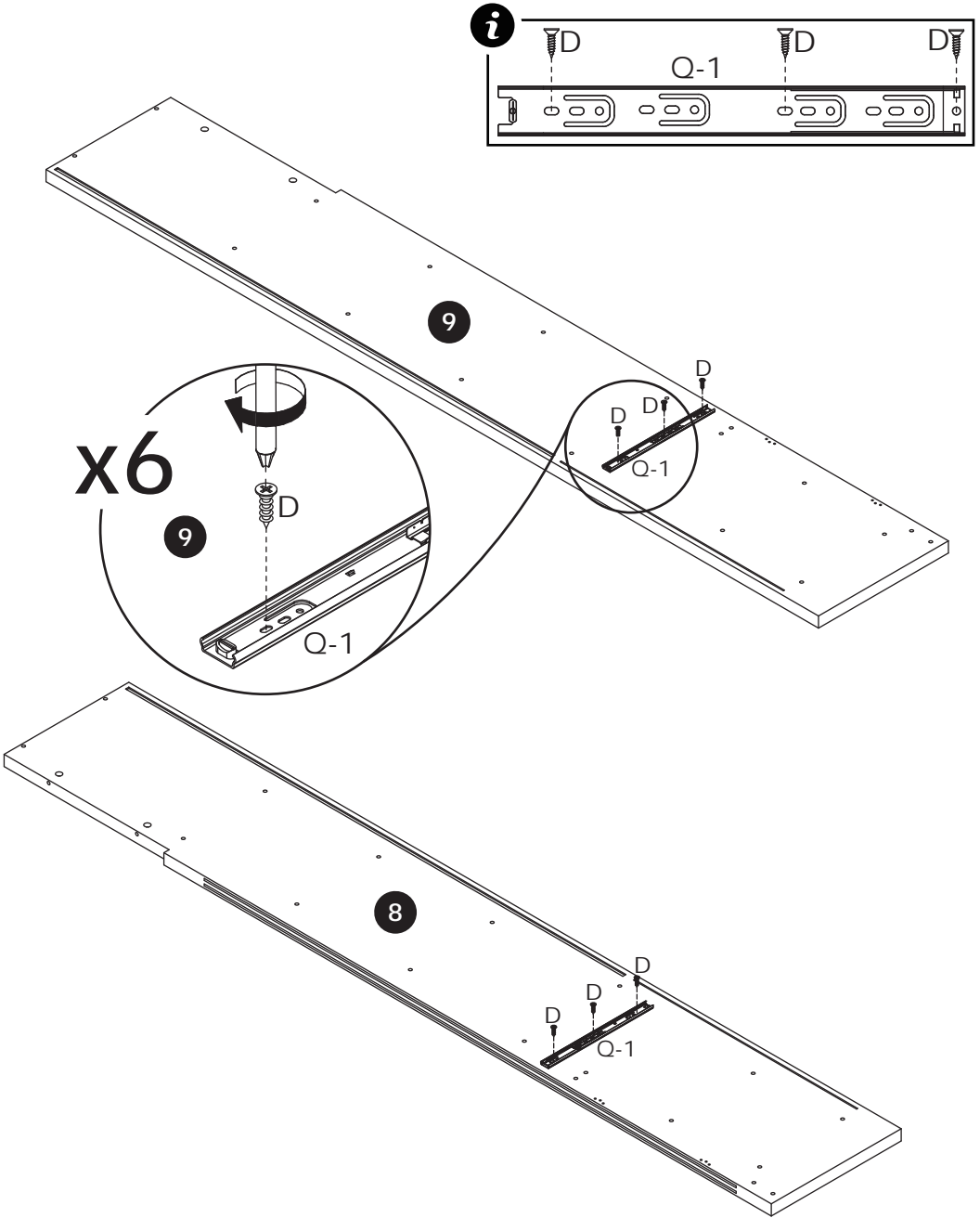
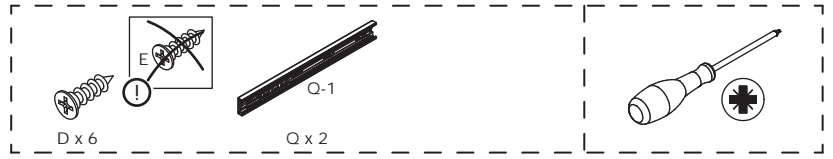

03

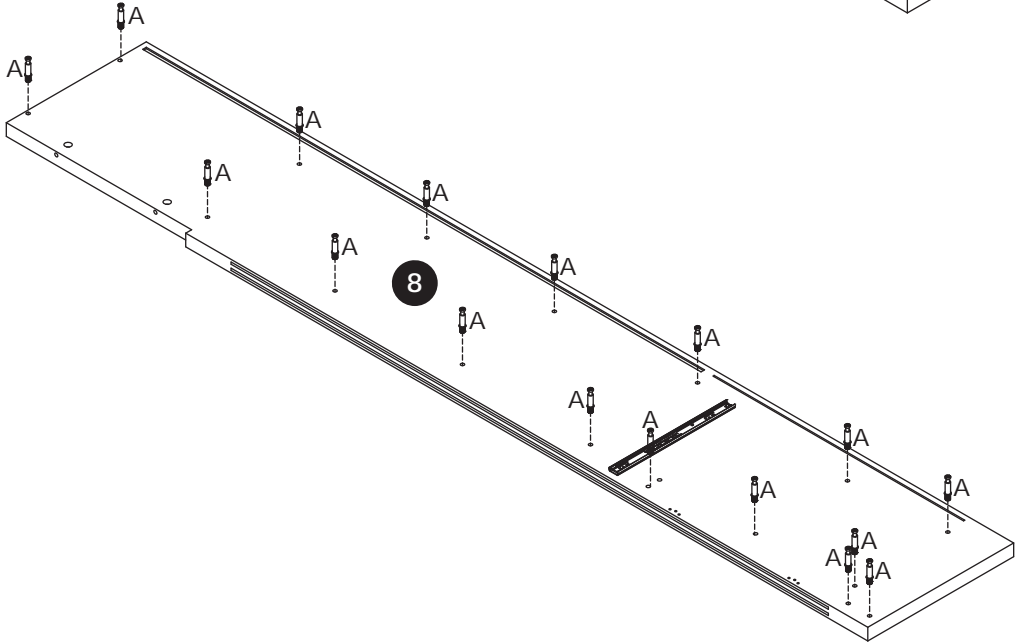
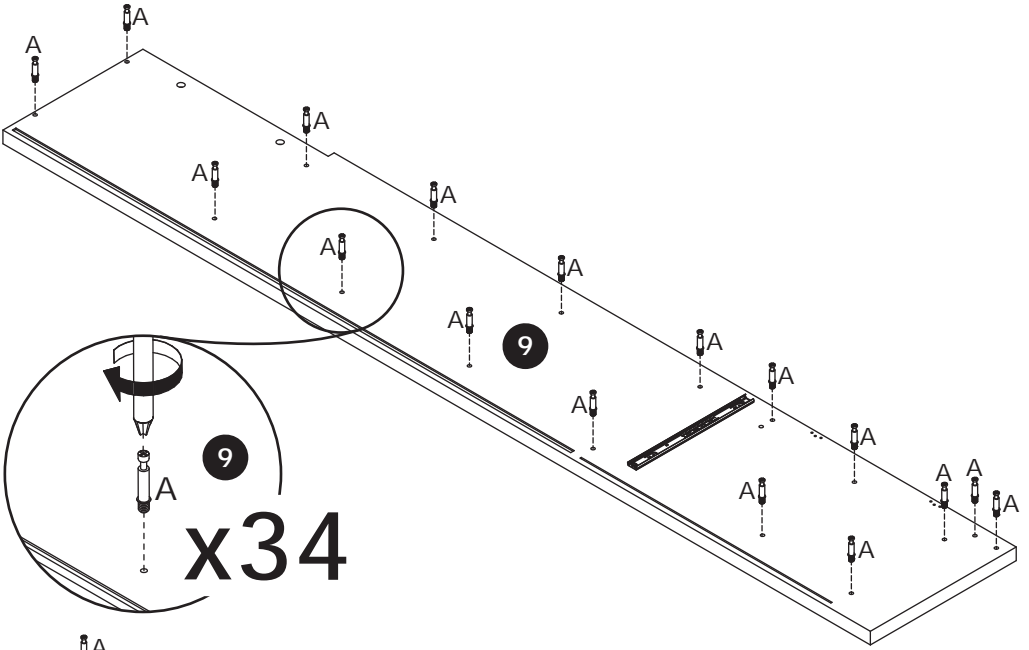

04

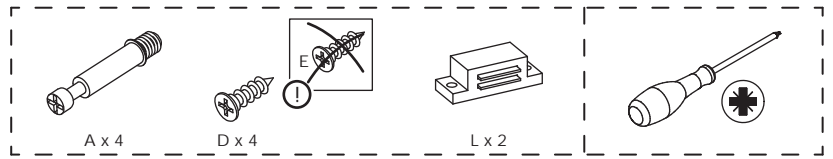

[EN] Attach cam bolt (A) to panel 6, and secure magnetic catches (L) to panel 4 with screws (D).
[ES] Fije el perno excéntrico (A) al panel 6 y asegure los cierres magnéticos (L) al panel 4 con tornillos (D).

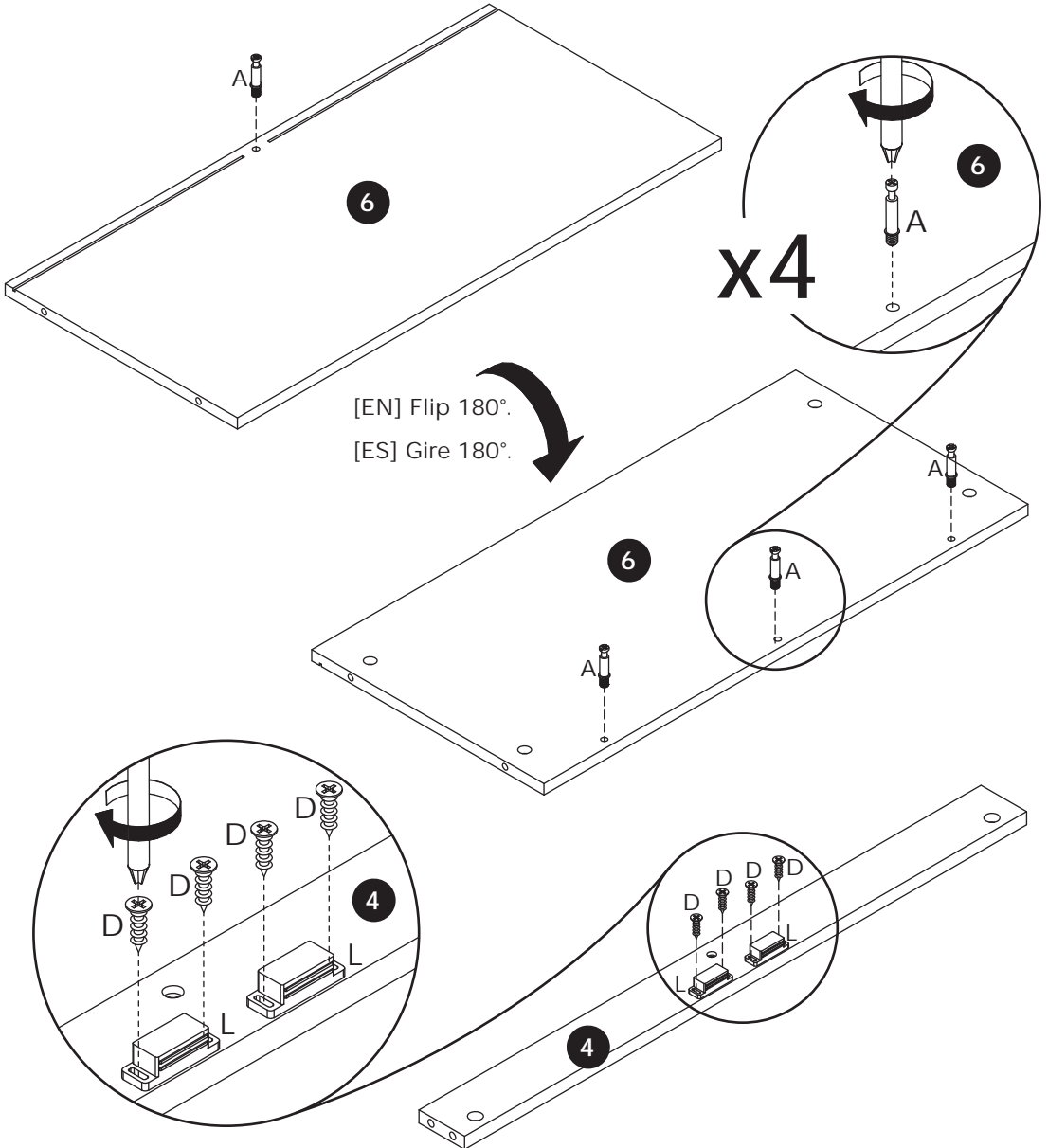

05

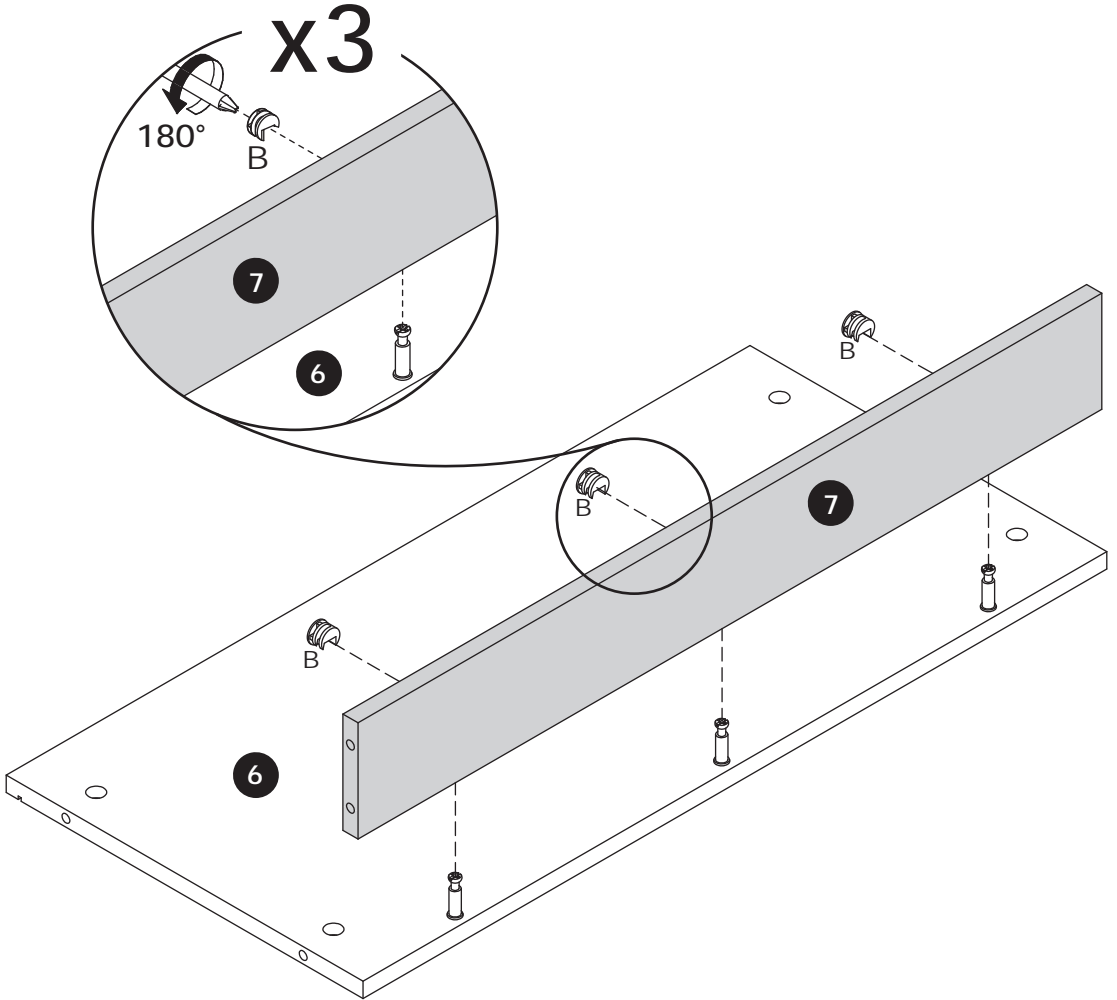

06

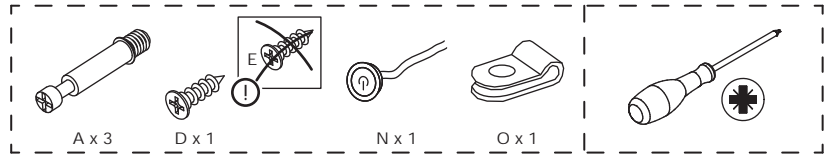

[EN] Attach cam bolt (A) to panel 24, and secure retaining clip (O) to panel 24 with screw (D).
Insert accessory (N) through retaining clip (O).

[ES] Fije el perno excéntrico (A) al panel 24 y asegure el clip de retención (O) al panel 24 con el tornillo (D).
Inserte el accesorio (N) a través del clip de retención (O).

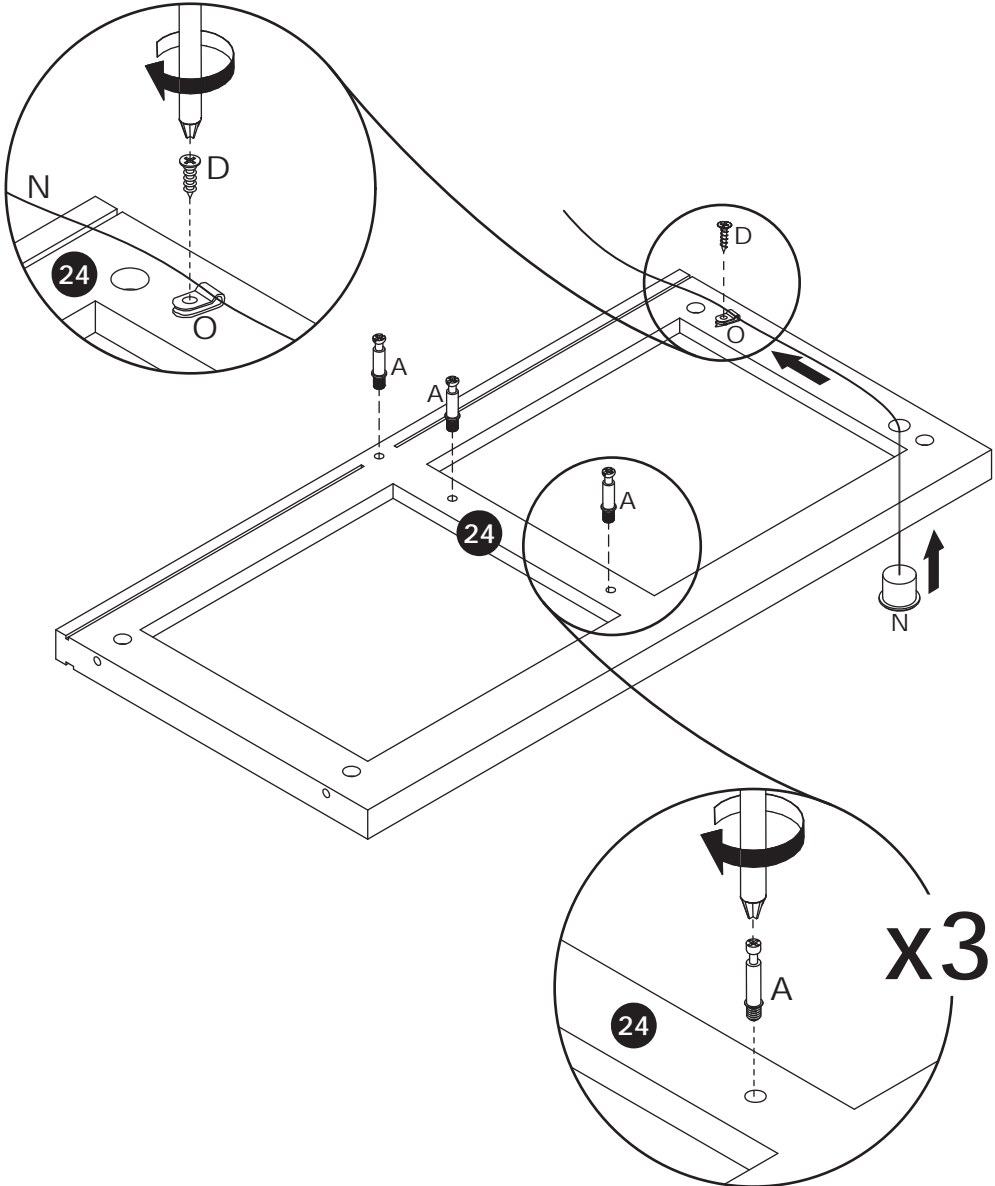

07

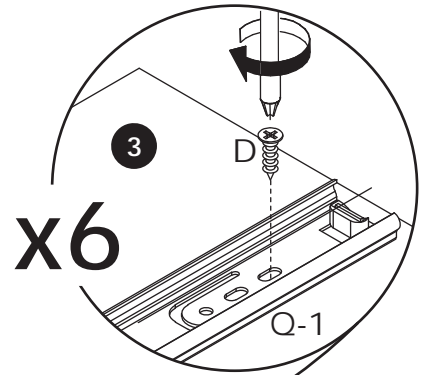
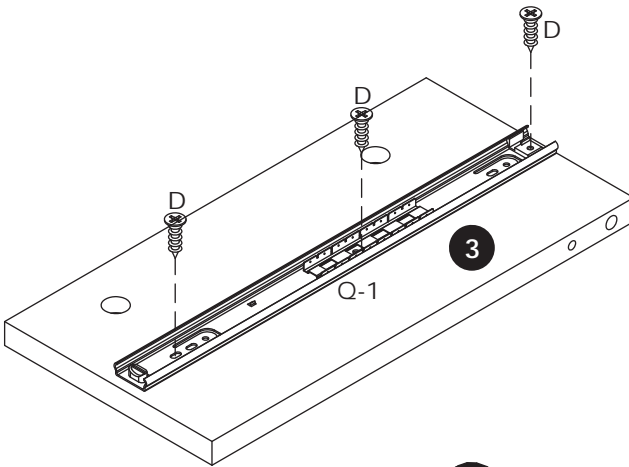
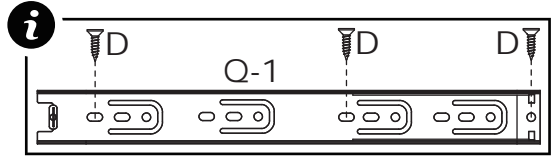
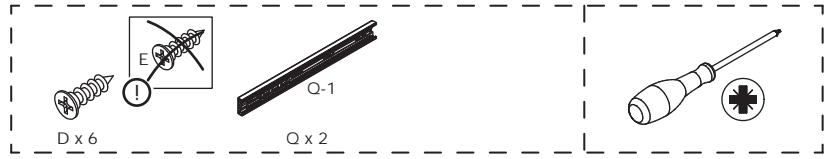

[EN] Flip 180°.
[ES] Gire 180°.

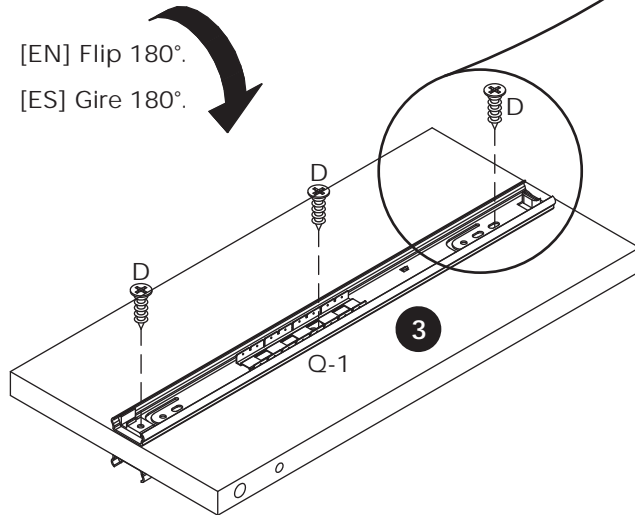

08



B x 2

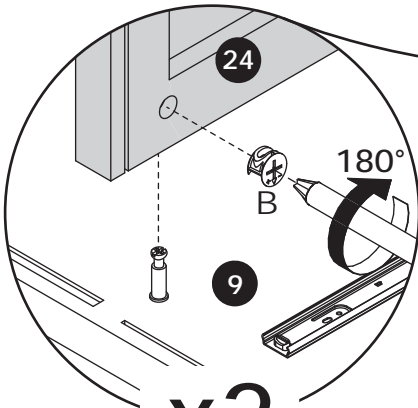
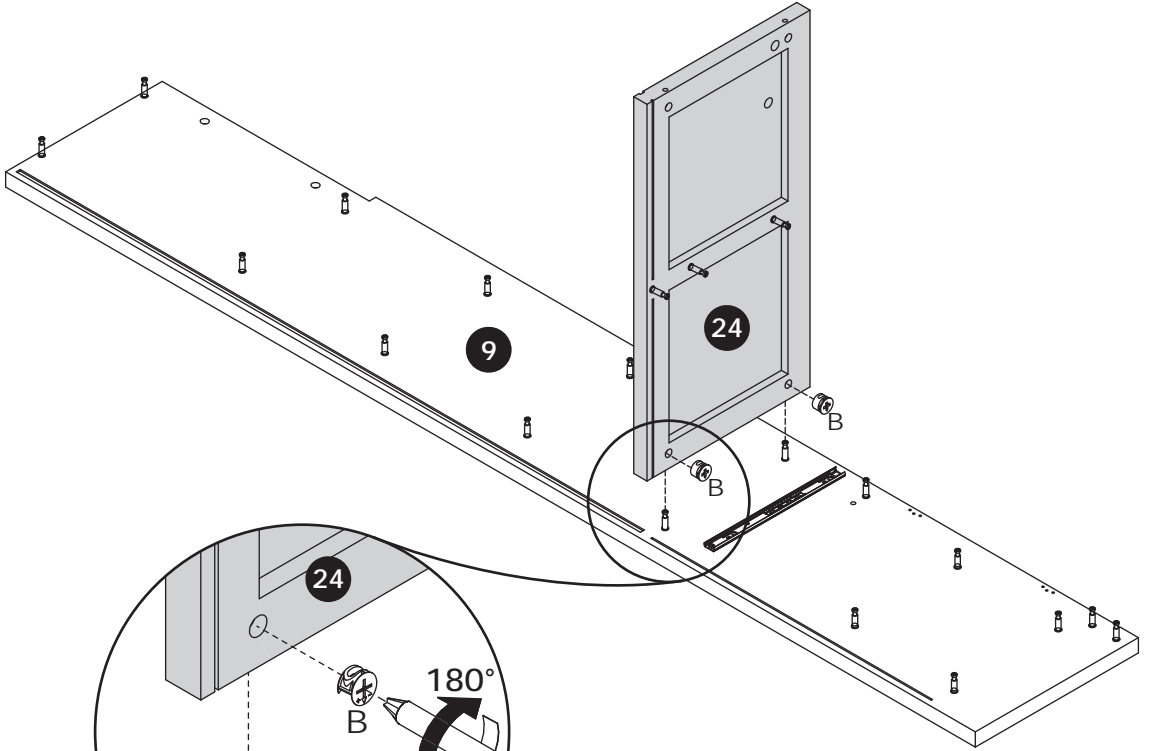
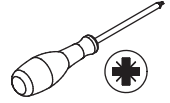

x2



2 ADULTS

09

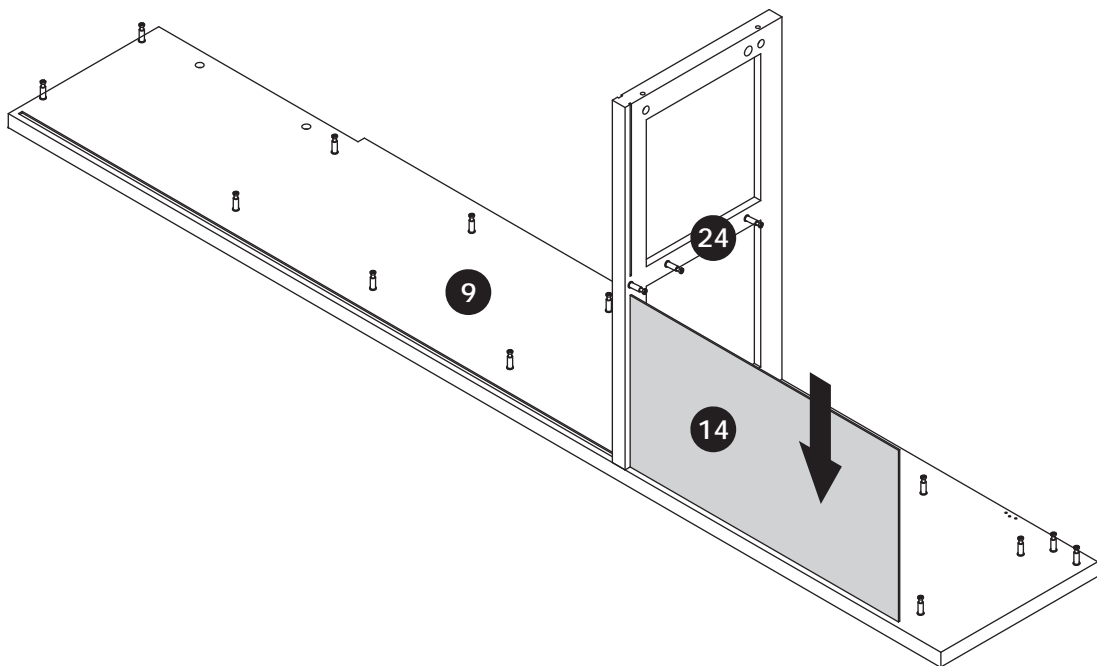

10

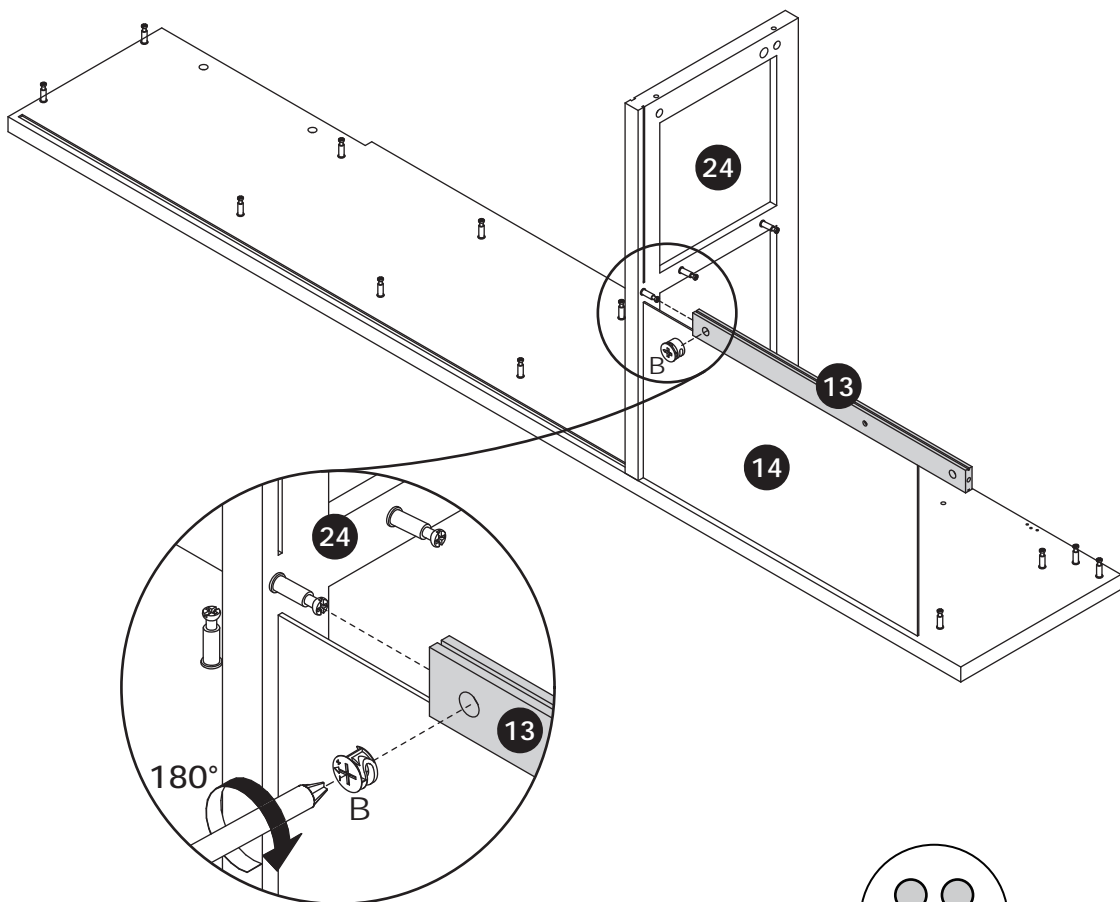

2 ADULTS

11

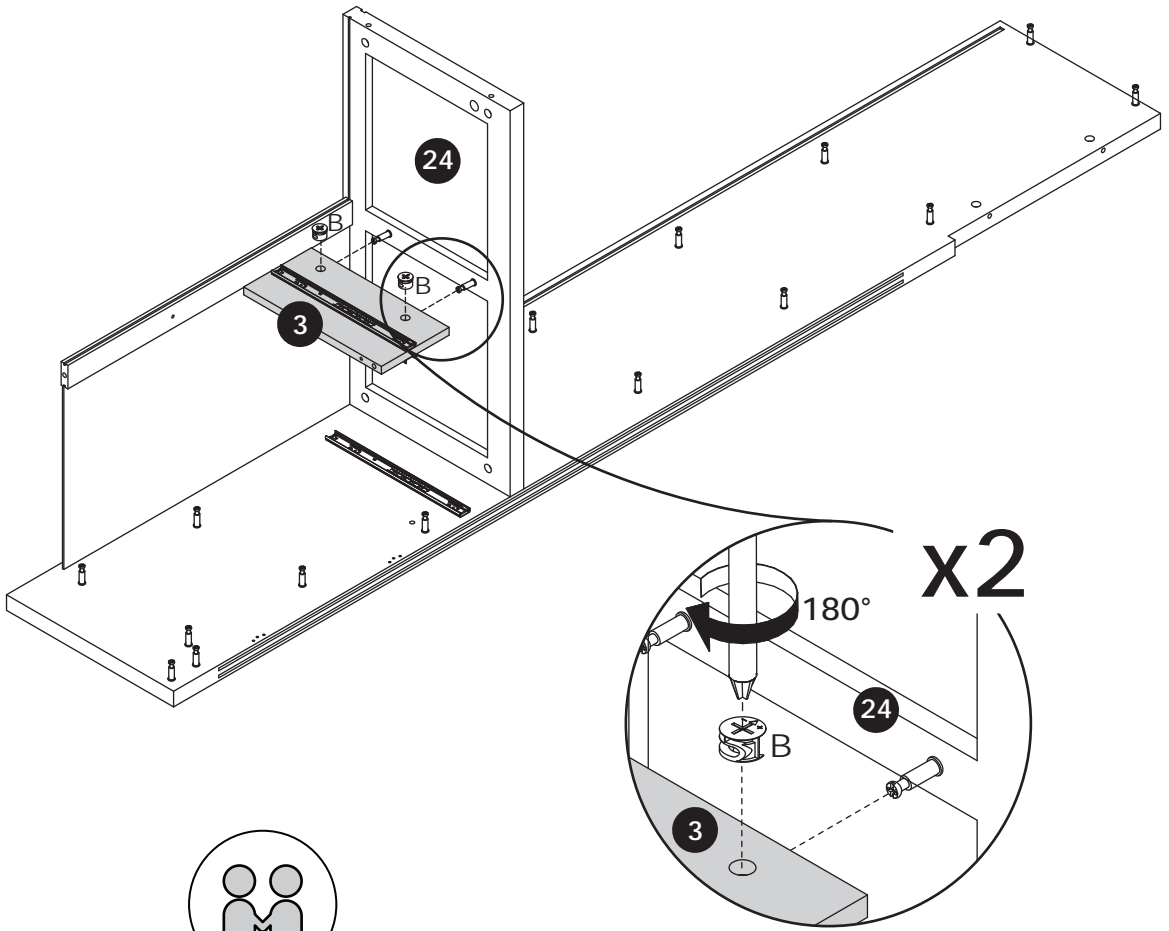

2 ADULTS

12

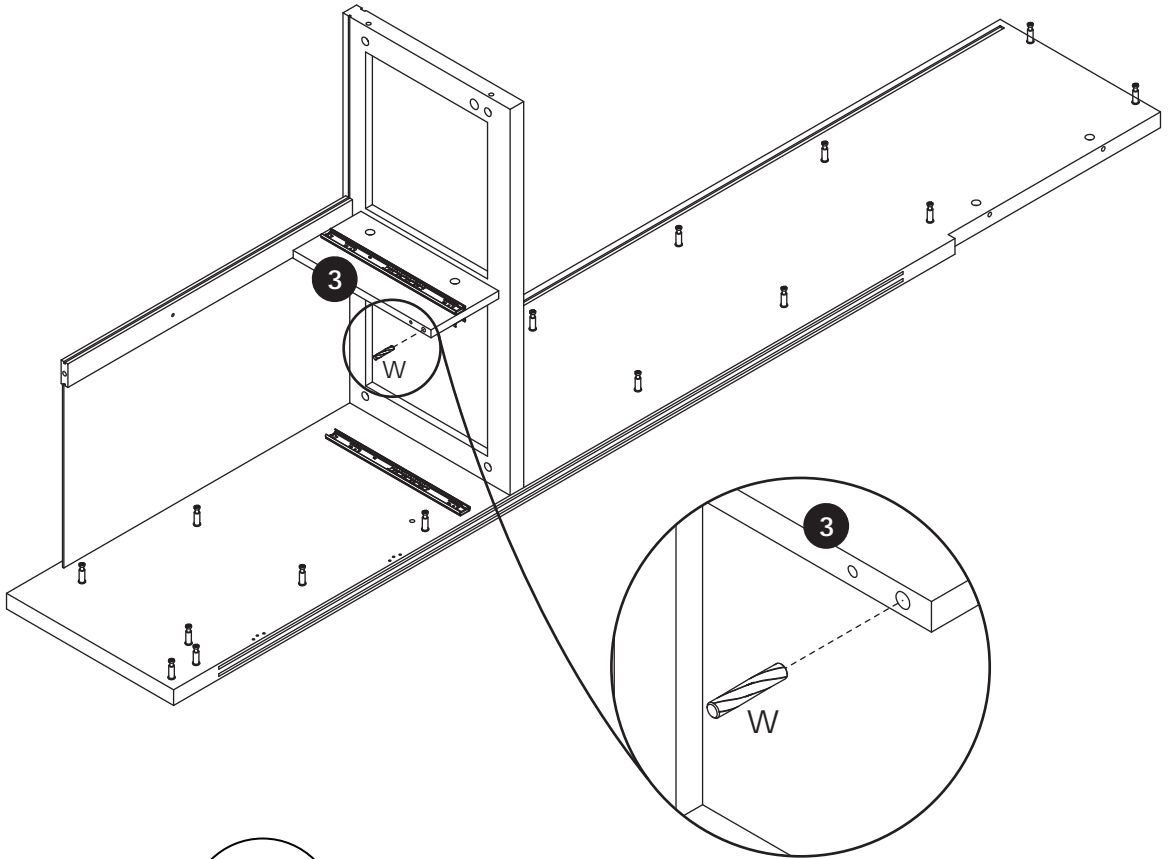

2 ADULTS

13

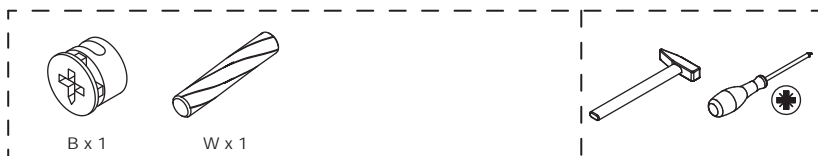

[EN] Connect panel 4 to panel 9 with dowel (W), then join panel 4 to panel 3.

Insert cam lock (B) into panel 4 and turn to lock.

[ES] Conecte el panel 4 al panel 9 con la espiga (W), luego una el panel 4 al panel 3.

Inserte el cierre excéntrico (B) en el panel 4 y gírelo para bloquearlo.

i [EN] Tilt the component, align it with the lower hole position, then align it with the intermediate hole position.

[ES] Incline el componente, alinéelo con la posición del orificio inferior y luego alinéelo con la posición del orificio intermedio.

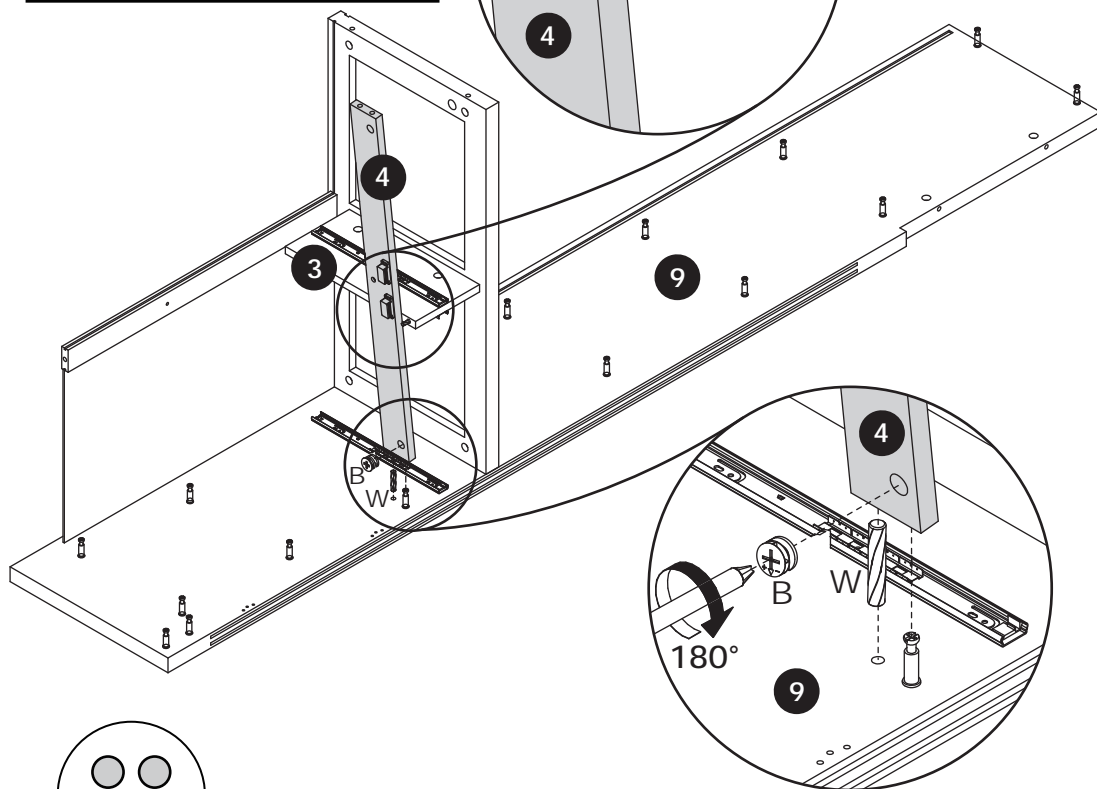
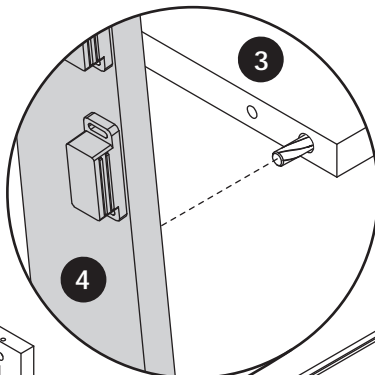

2 ADULTS

14

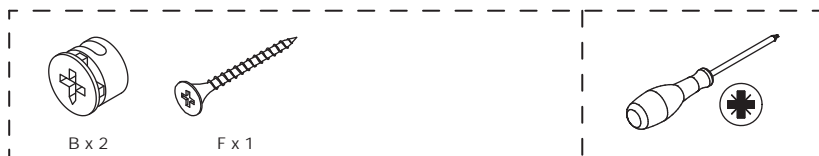

[EN] Secure panel 4 to panel 3 with screw (F).
Connect panel 5 to panel 9 and turn cam lock (B) to lock.

[ES] Asegure el panel 4 al panel 3 con el tornillo (F).
Conecte el panel 5 al panel 9 y gire el cierre excéntrico (B) para bloquearlo.

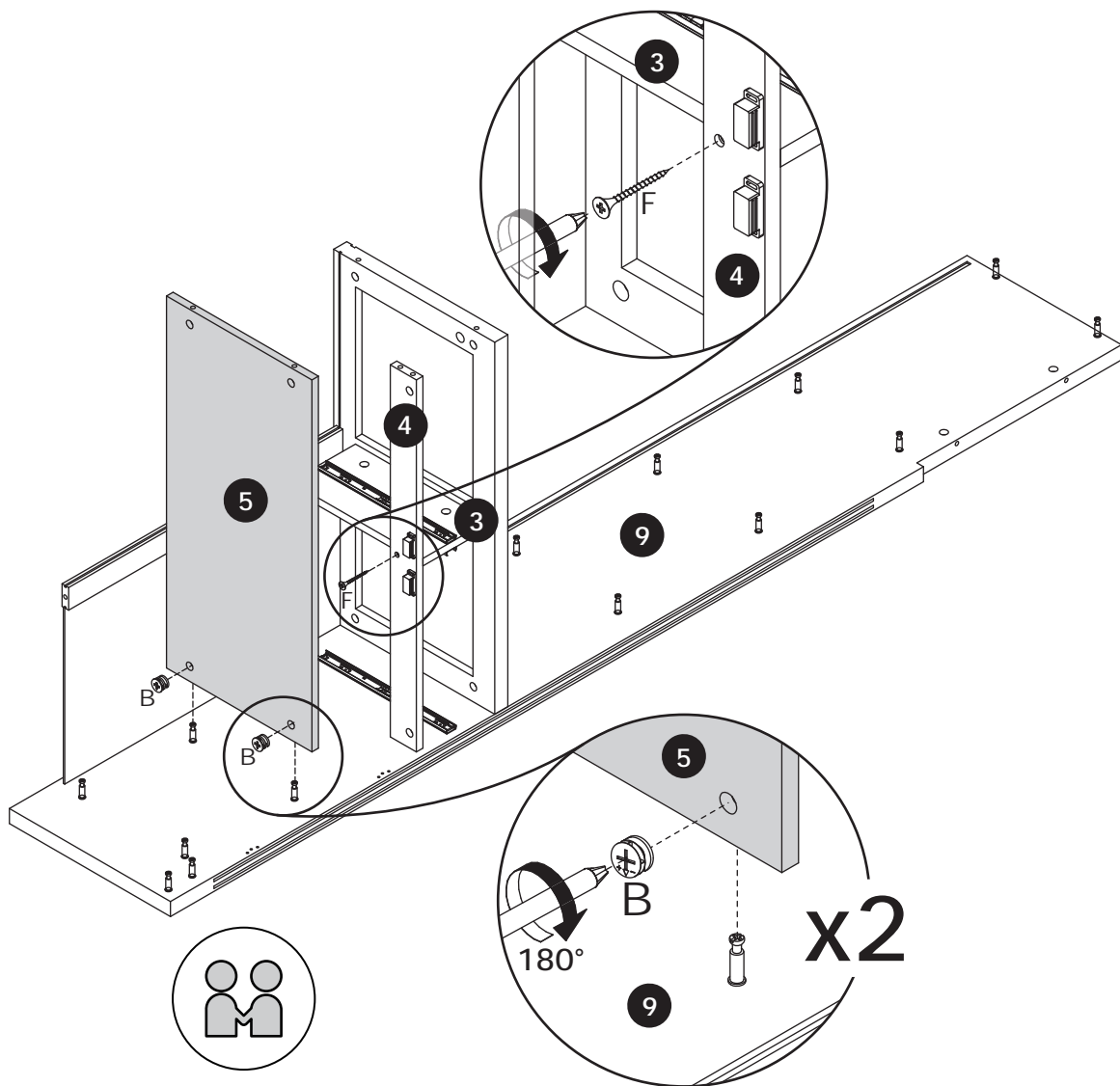

15



[EN] Tilt the component, align it with the lower hole position, then align it with the intermediate hole position.

[ES] Inclíne el componente, alinéelo con la posición del orificio inferior y luego alinéelo con la posición del orificio intermedio.

[EN] Secure panel 13 to panel 5 with screw (F). Connect panels 7 and 6 to panels 9 and 13, and turn cam lock (B) to lock.

[ES] Asegure el panel 13 al panel 5 con el tornillo (F). Conecte los paneles 7 y 6 a los paneles 9 y 13, y gire el cierre excéntrico (B) para bloquearlo.

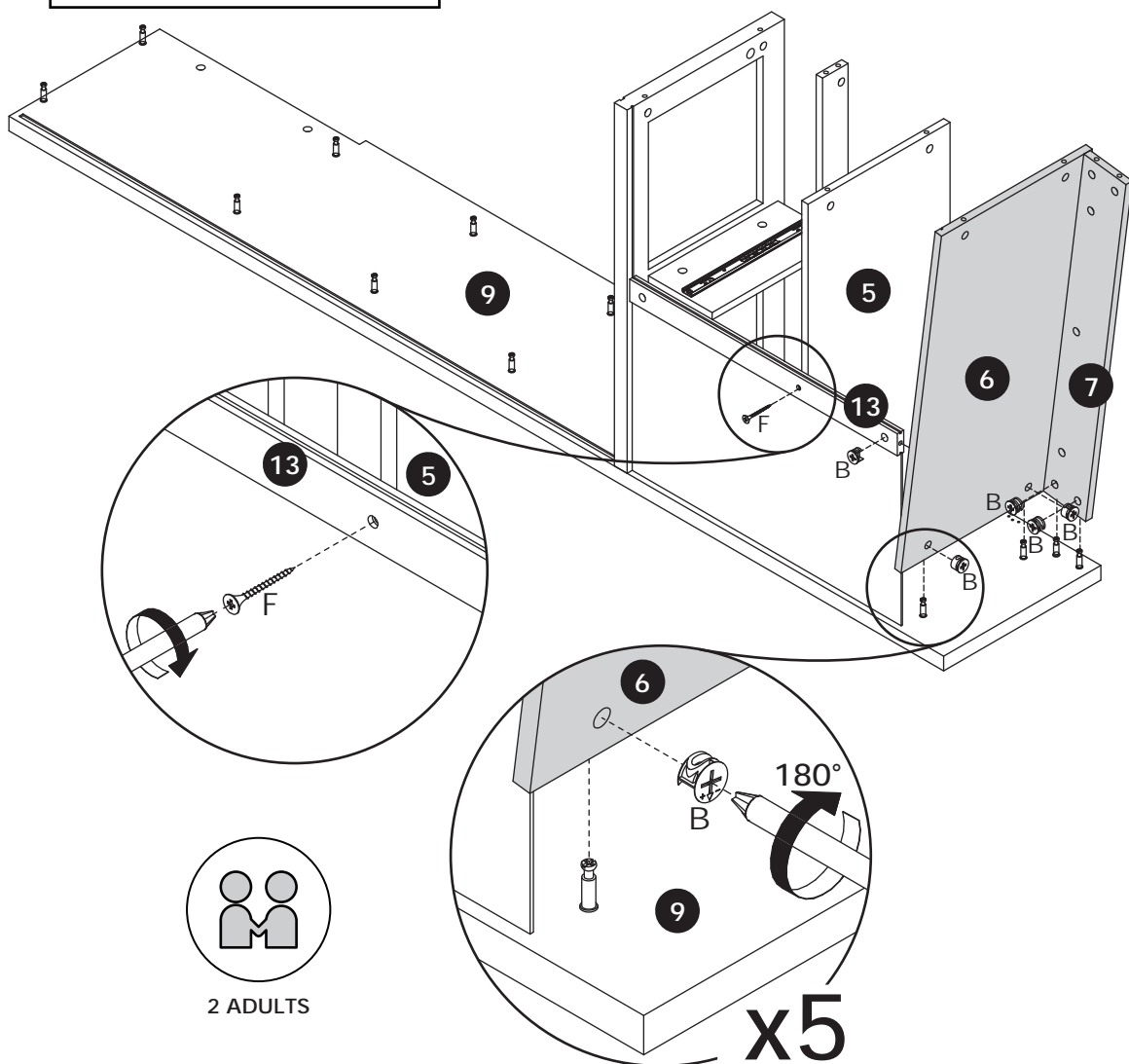

16

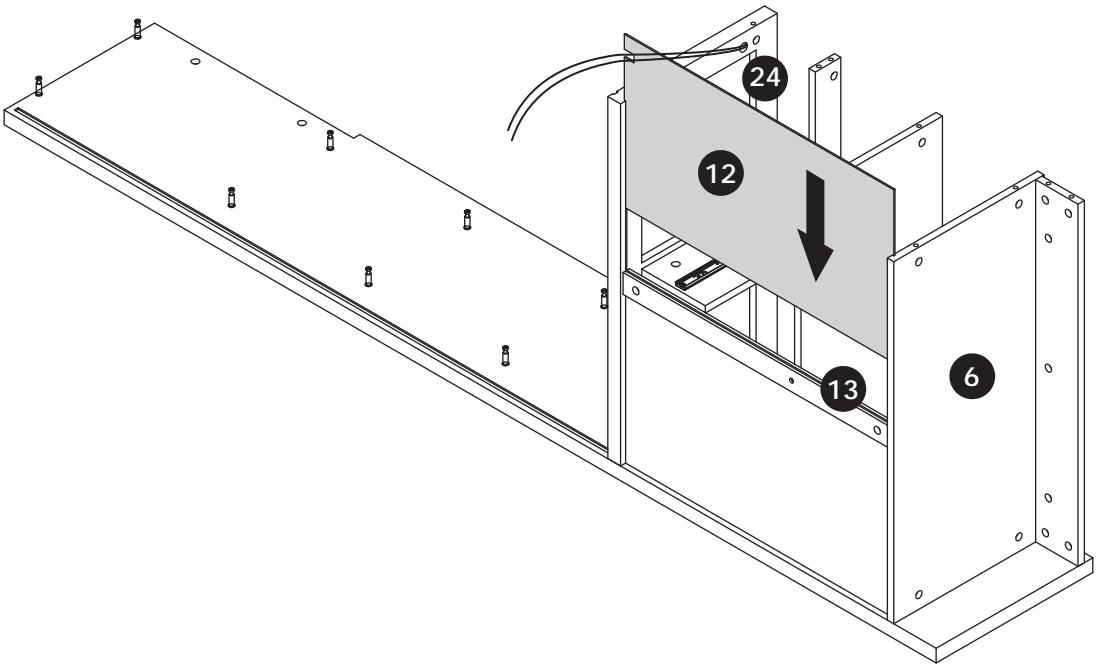

17

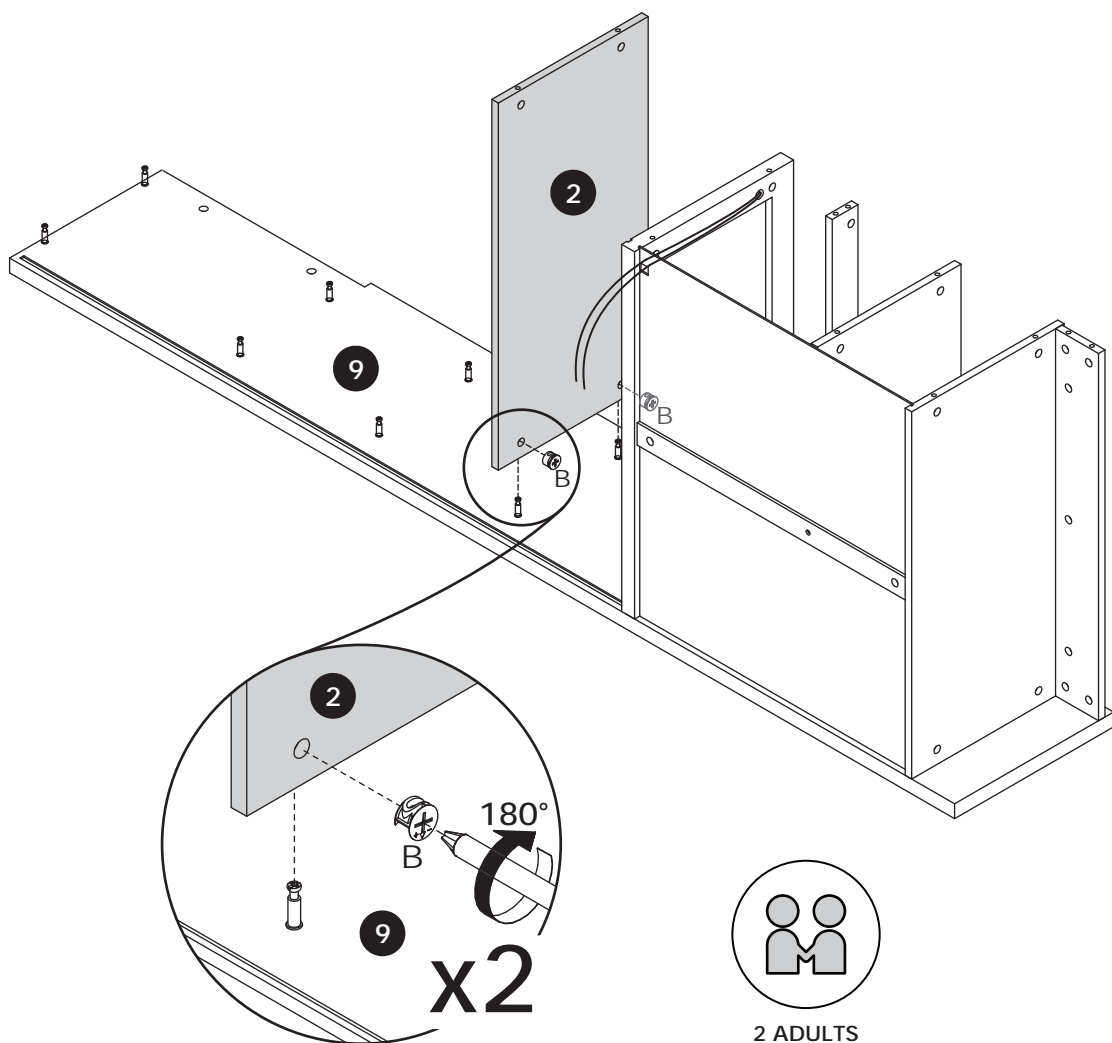

2 ADULTS

18

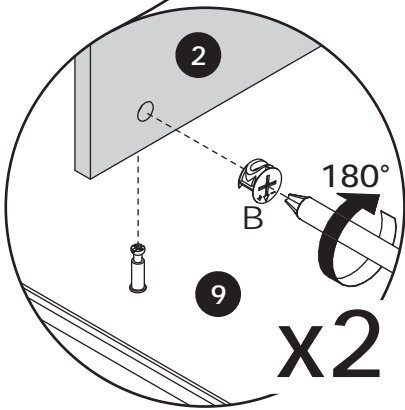
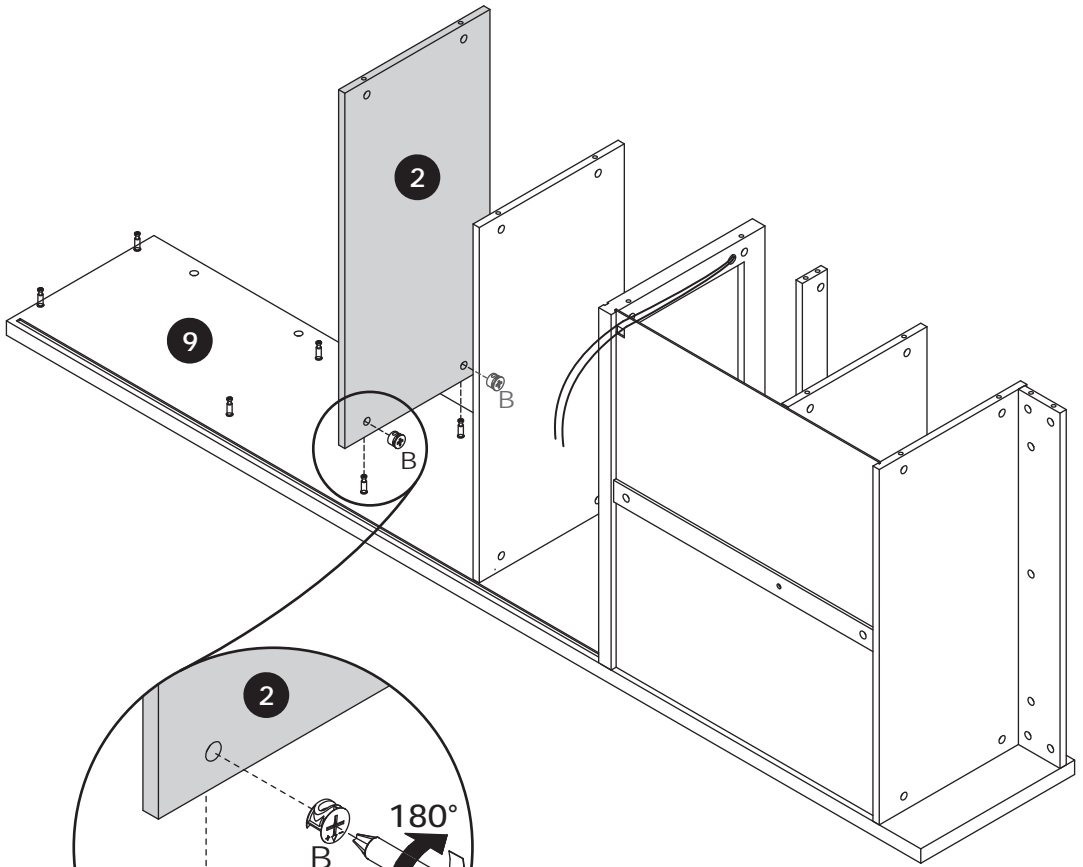

2 ADULTS

19

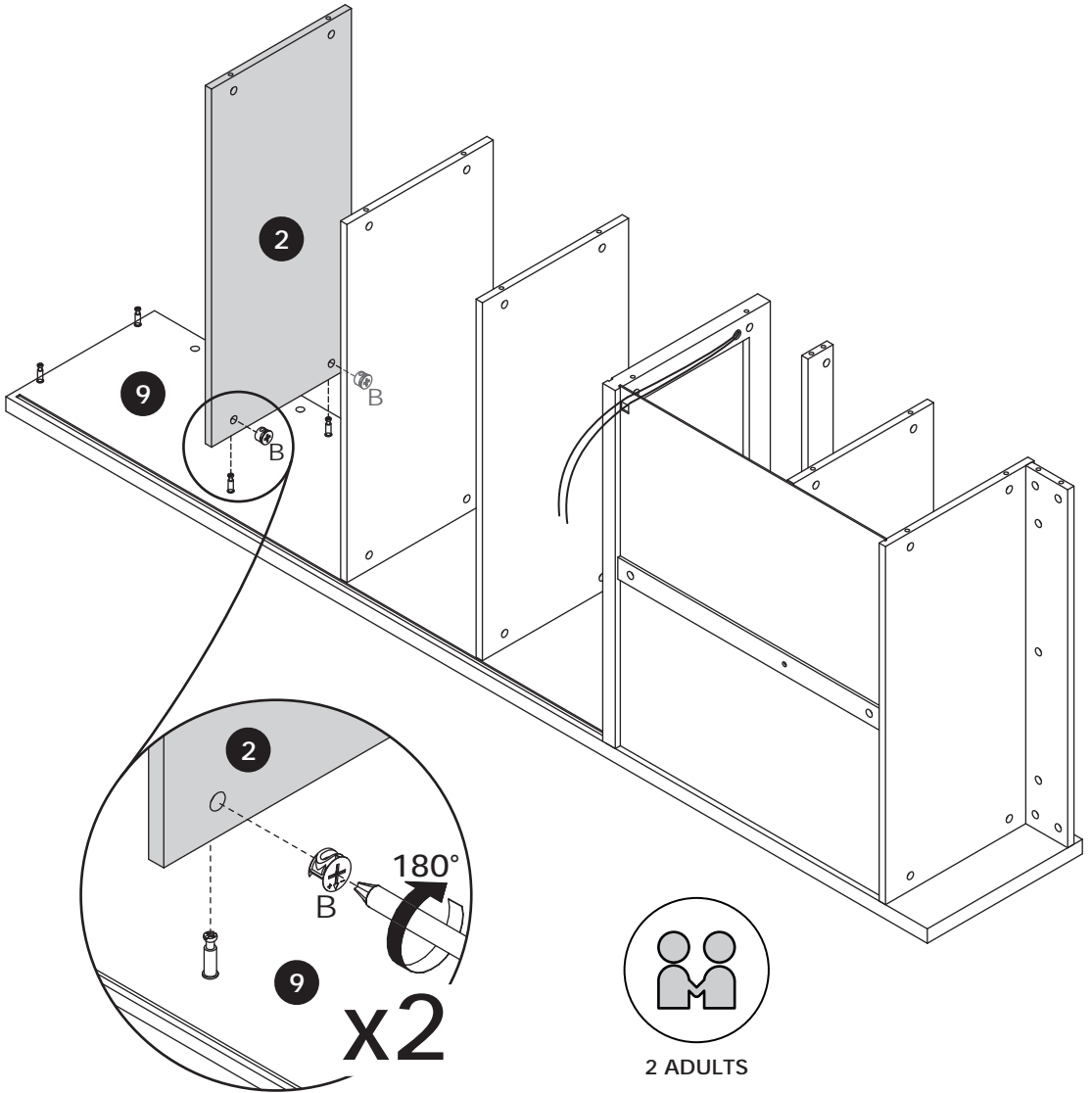

20

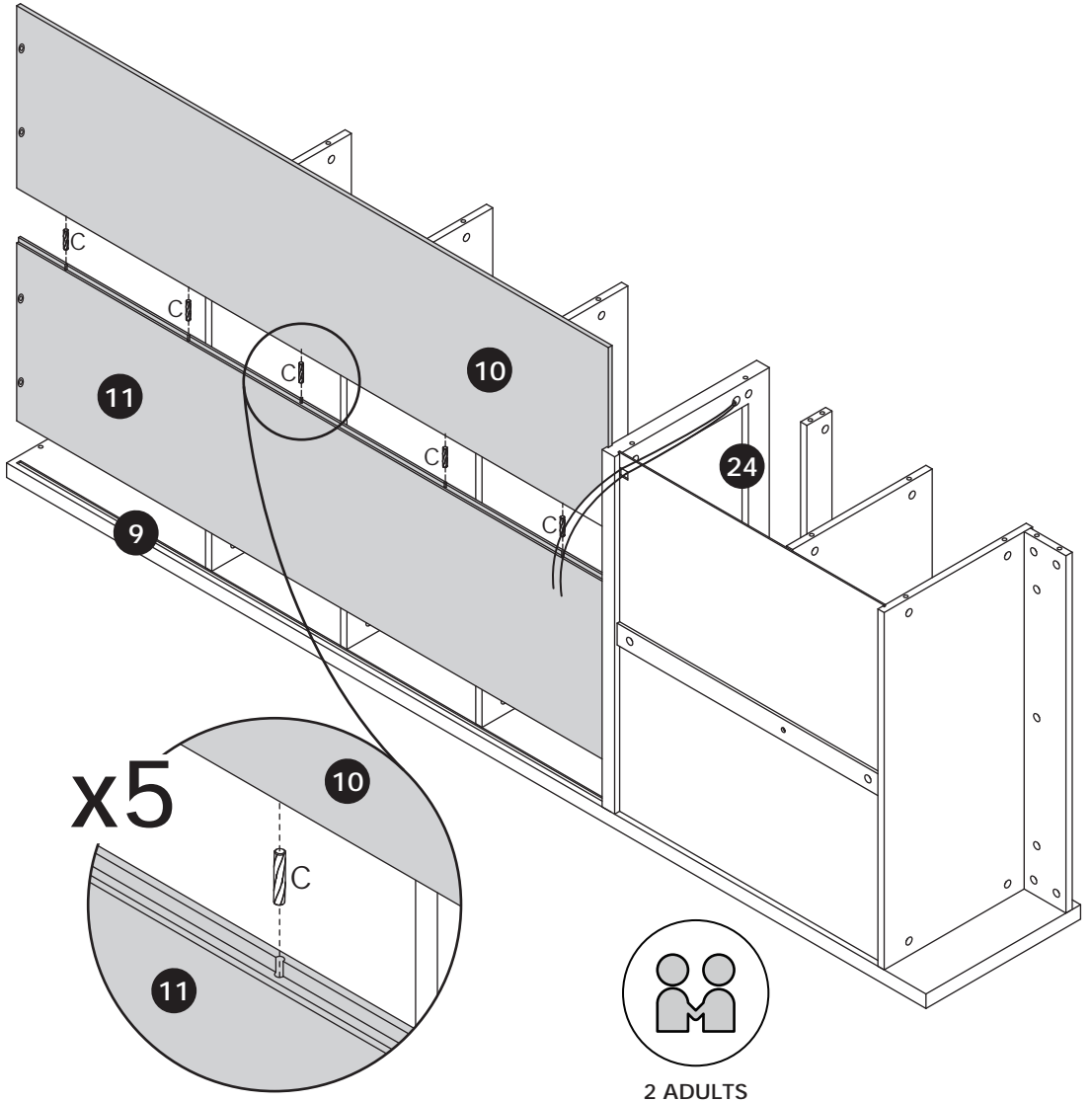

21

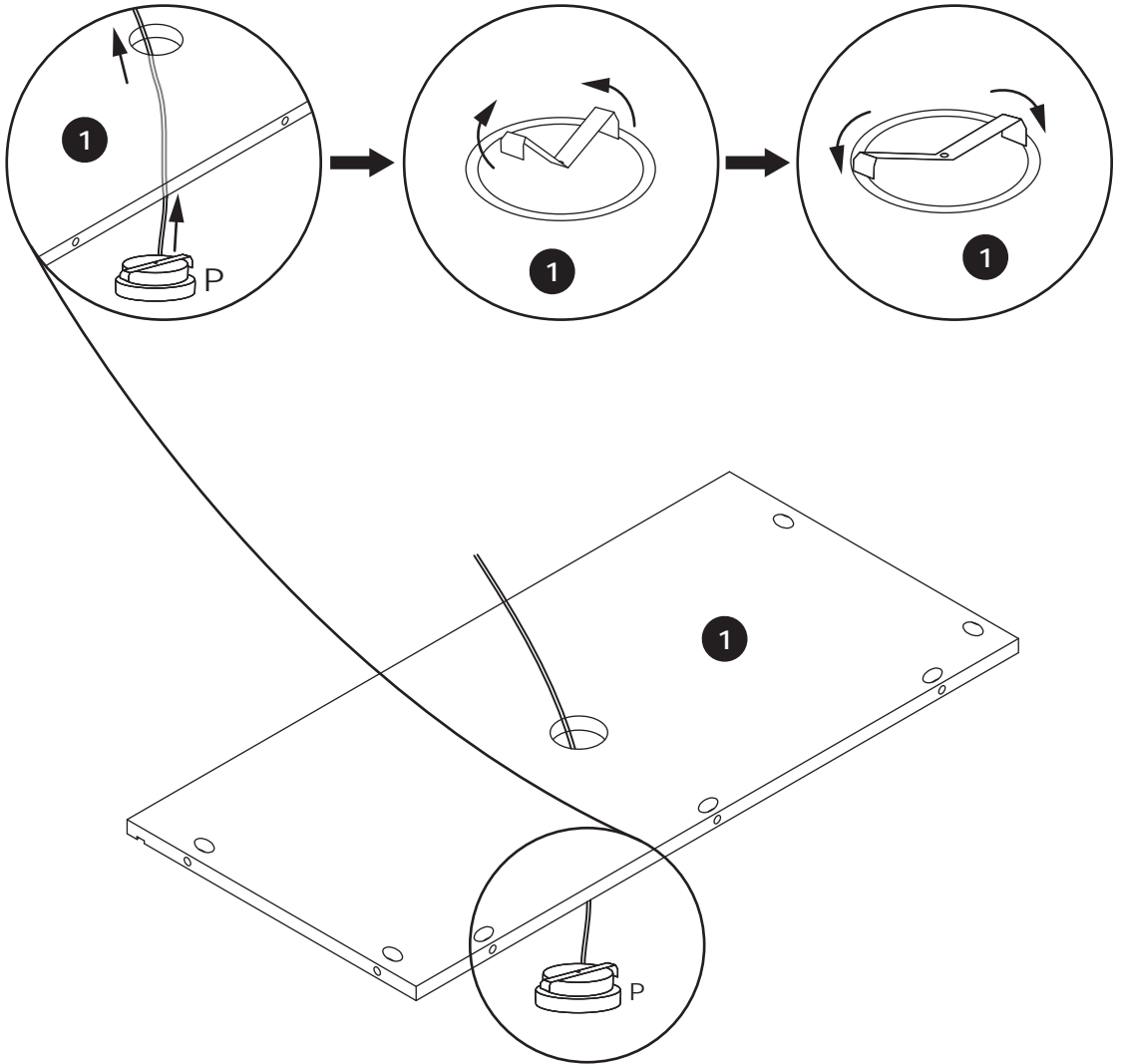

22

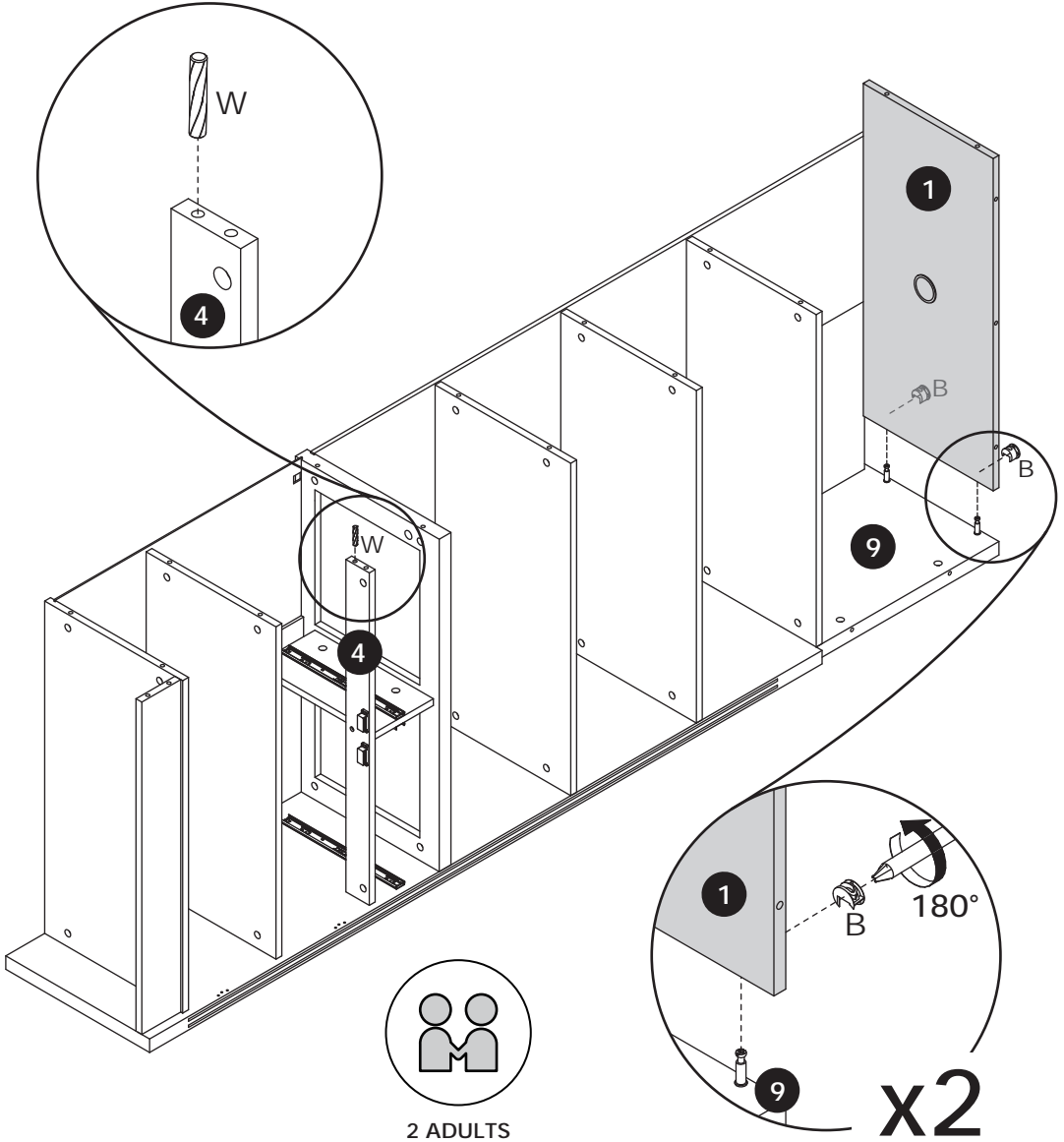

23



B x 17

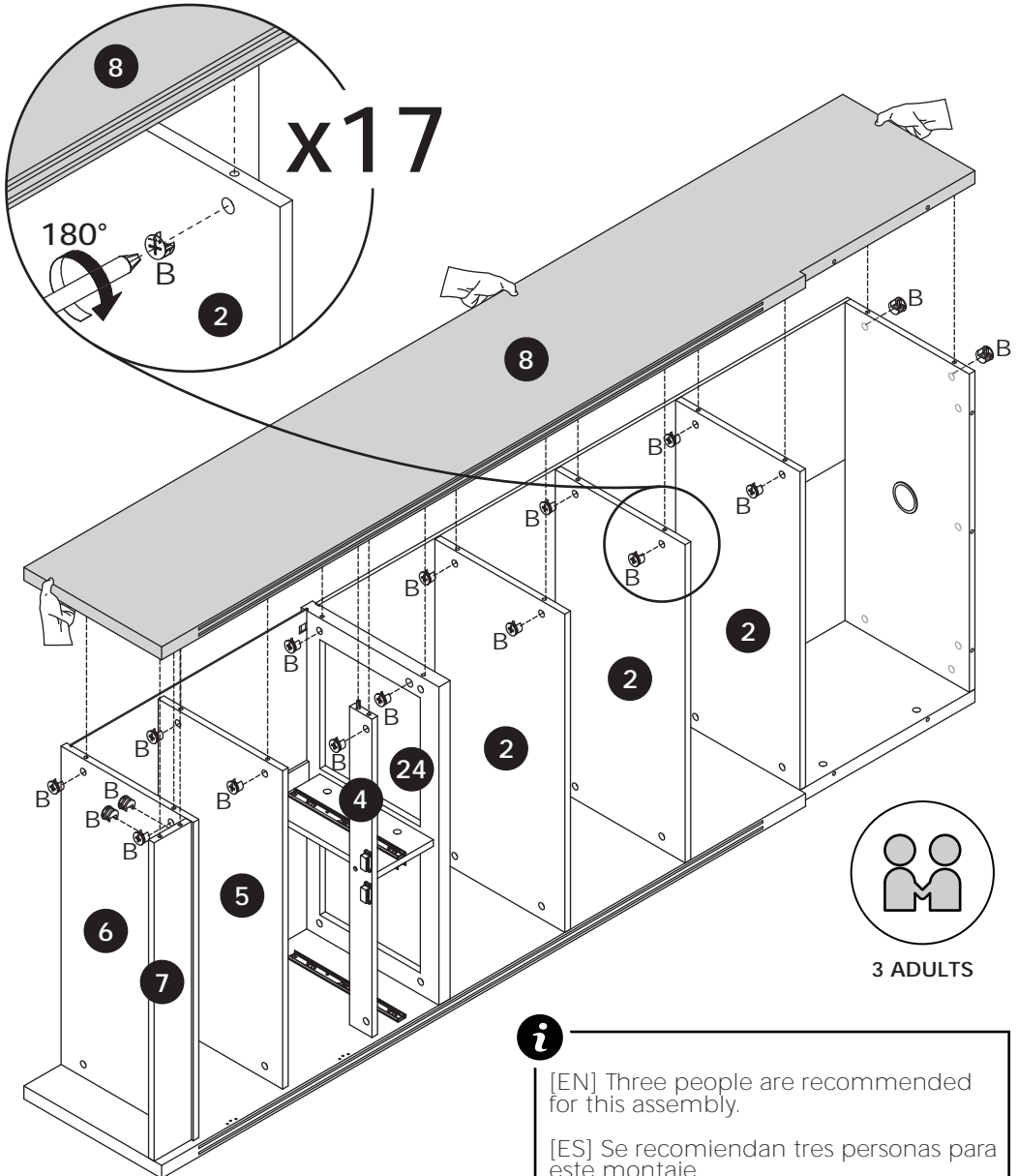
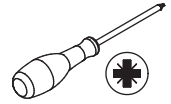

3 ADULTS



[EN] Three people are recommended for this assembly.

[ES] Se recomiendan tres personas para este montaje.

25



B x 7

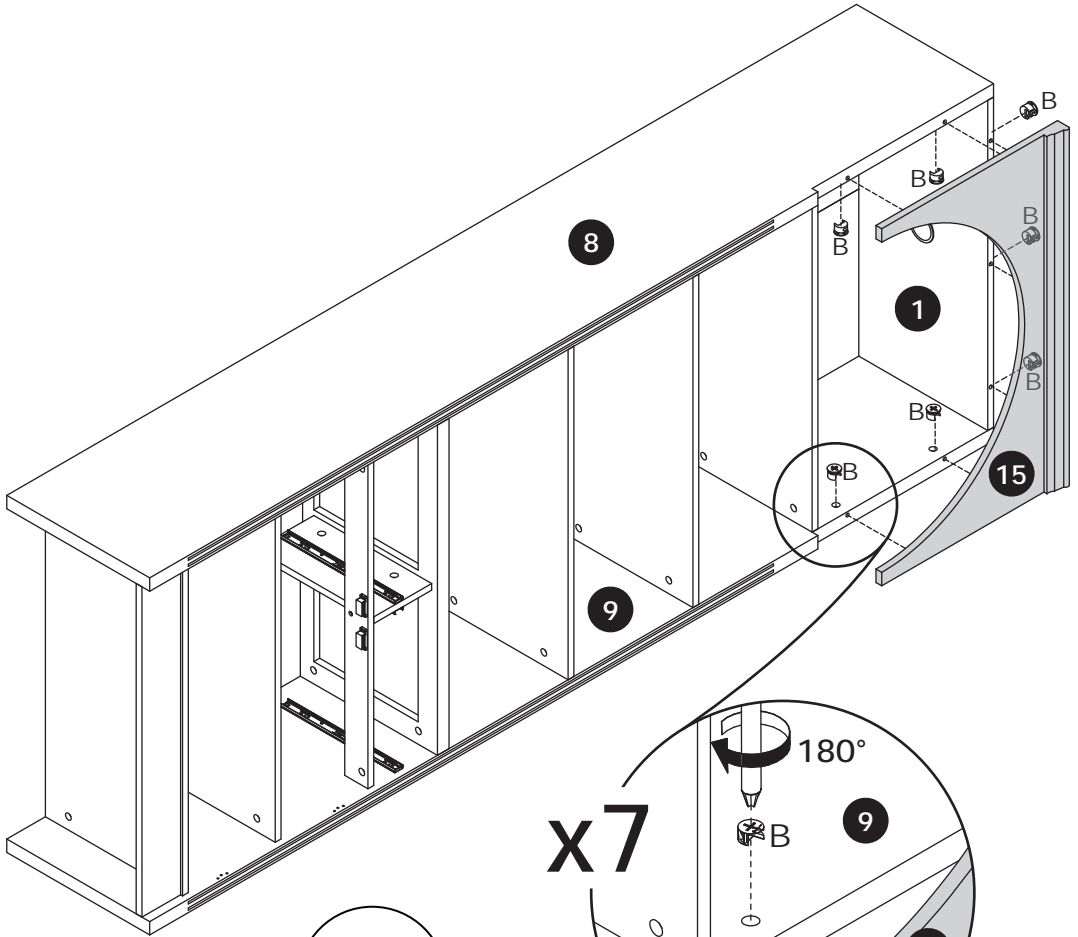
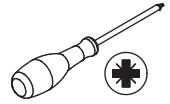

2 ADULTS

26

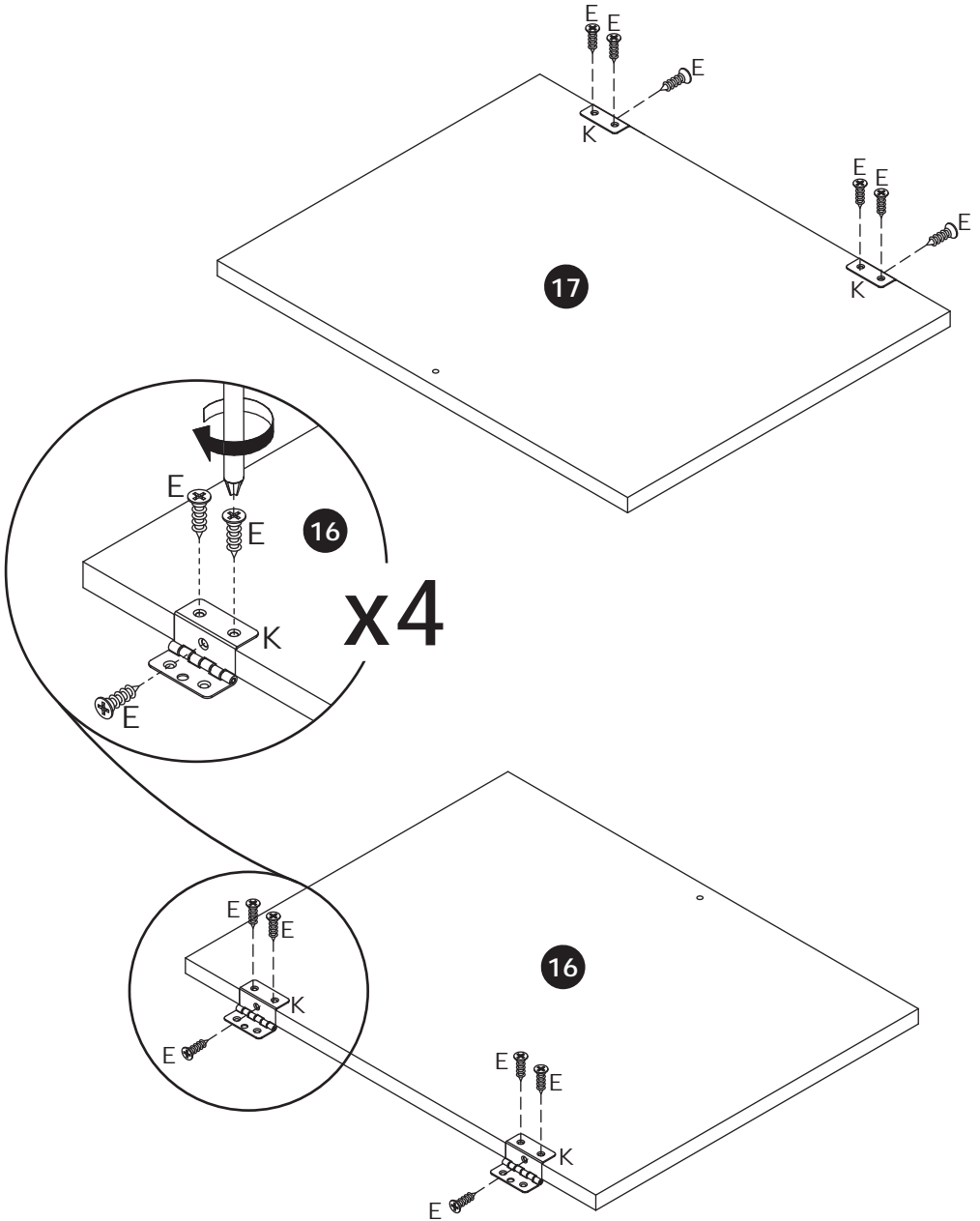

27

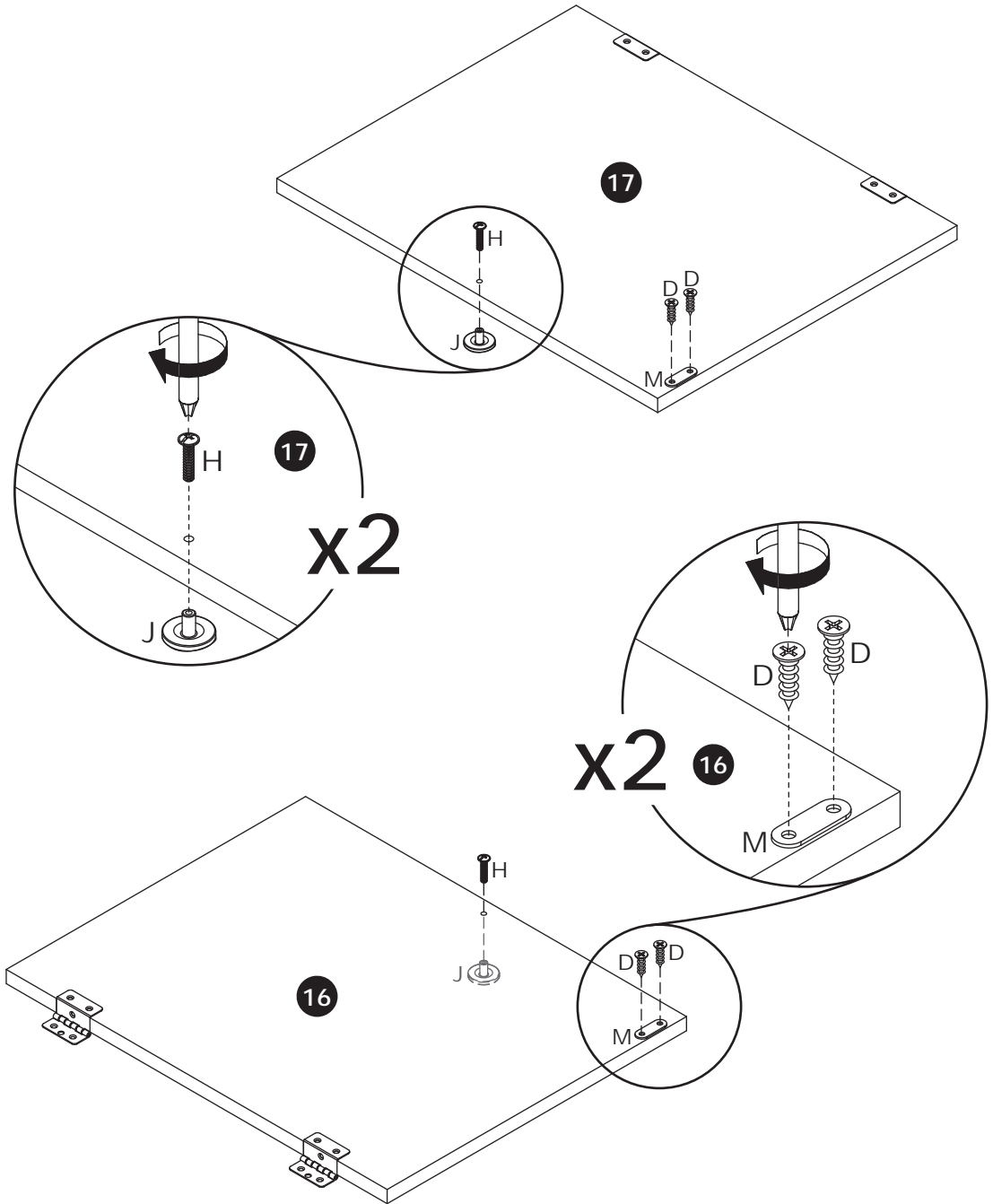
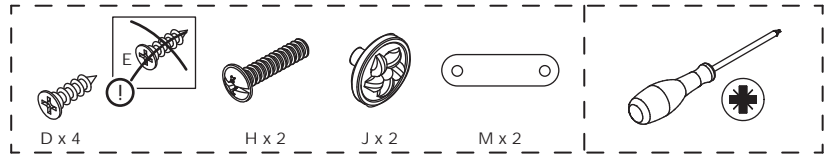

28

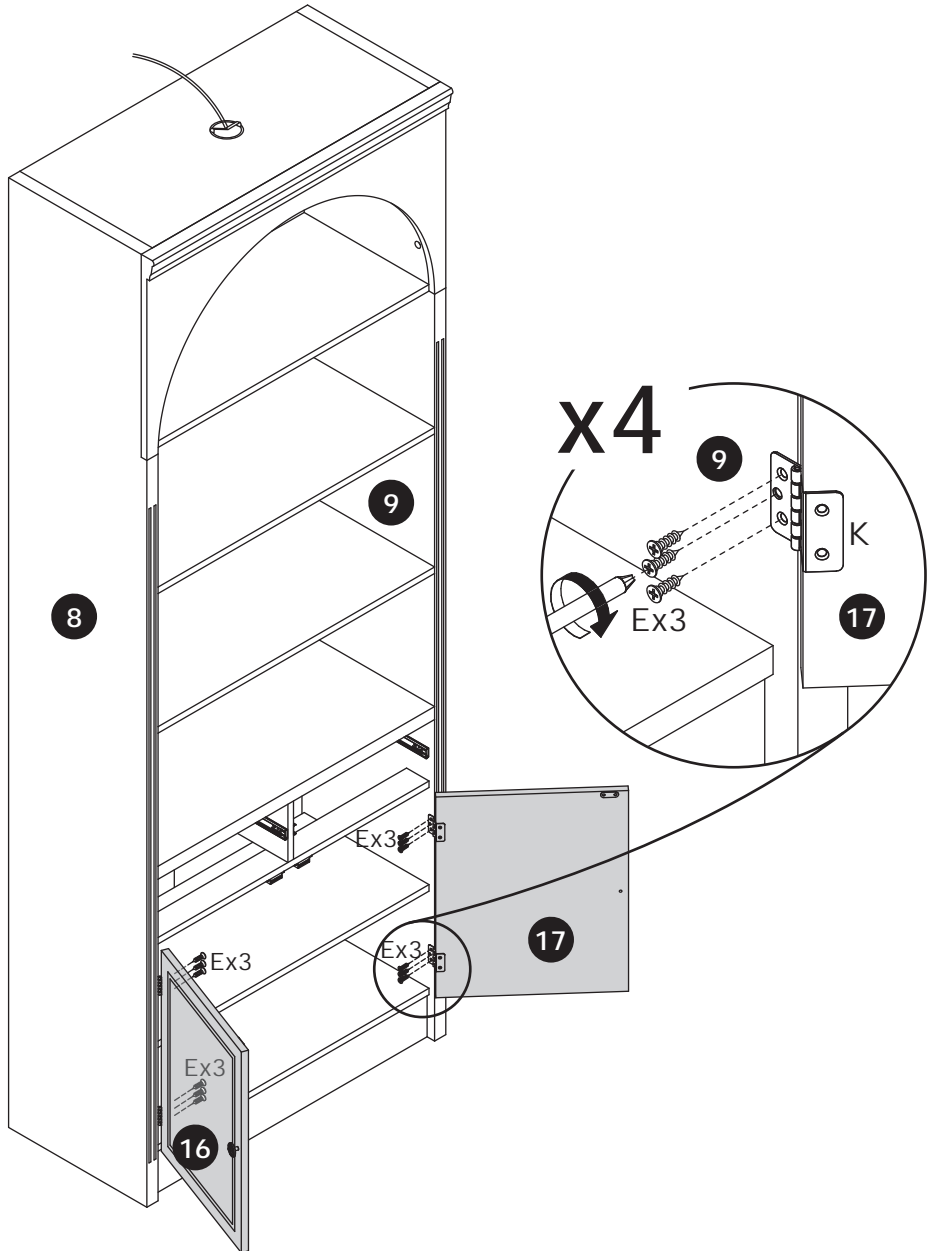

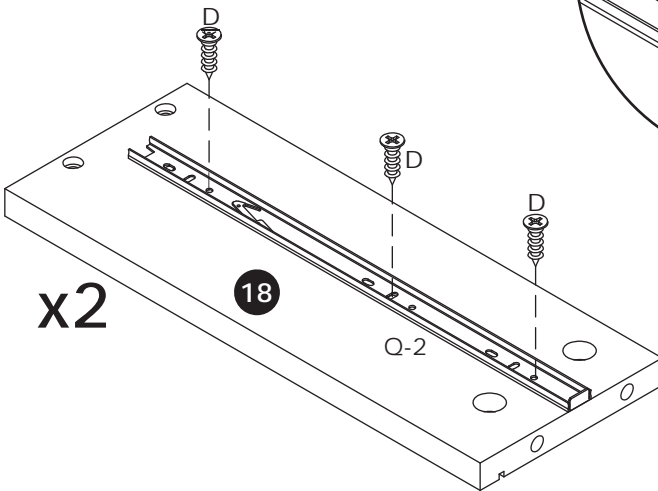
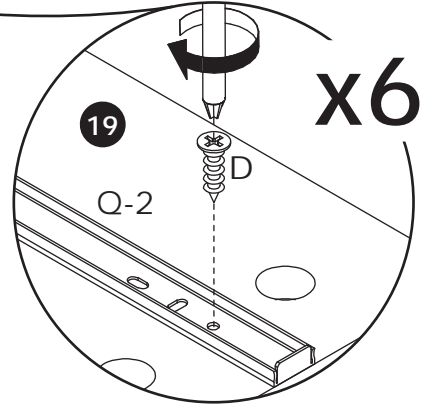
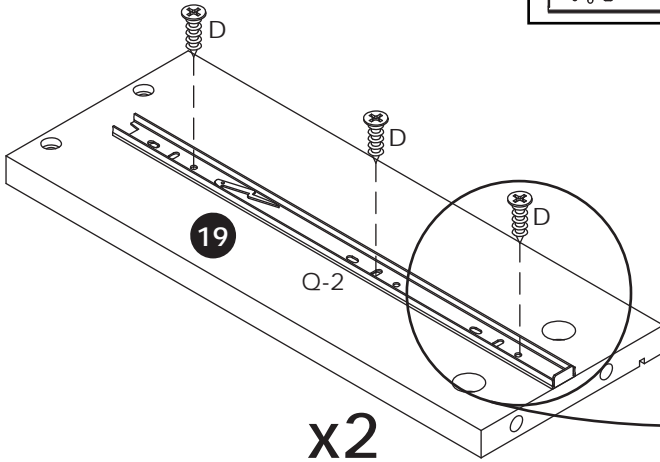
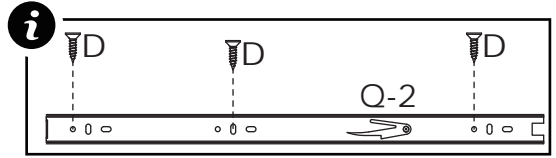
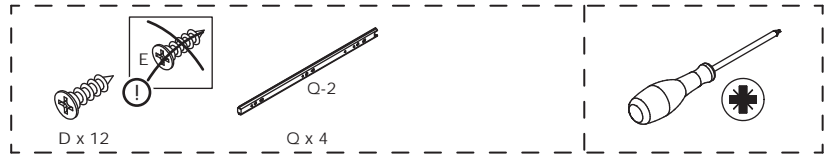

30

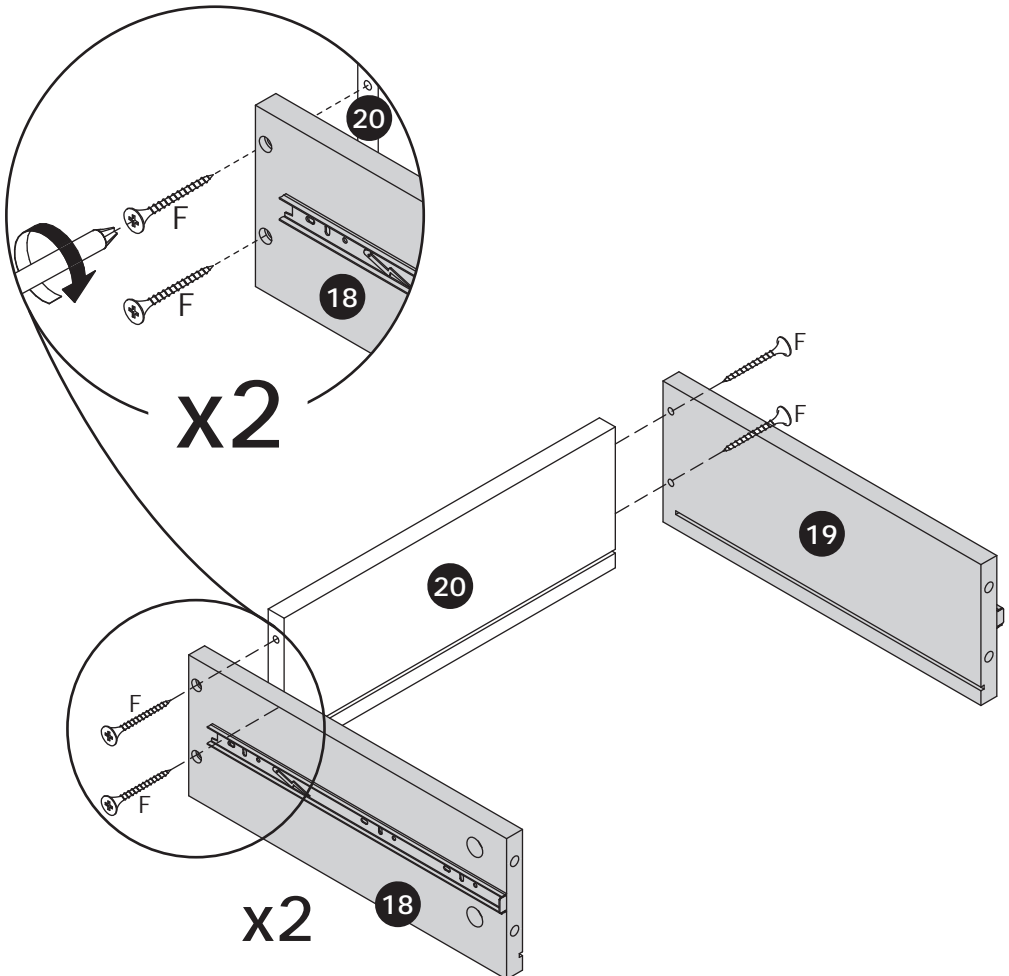

31

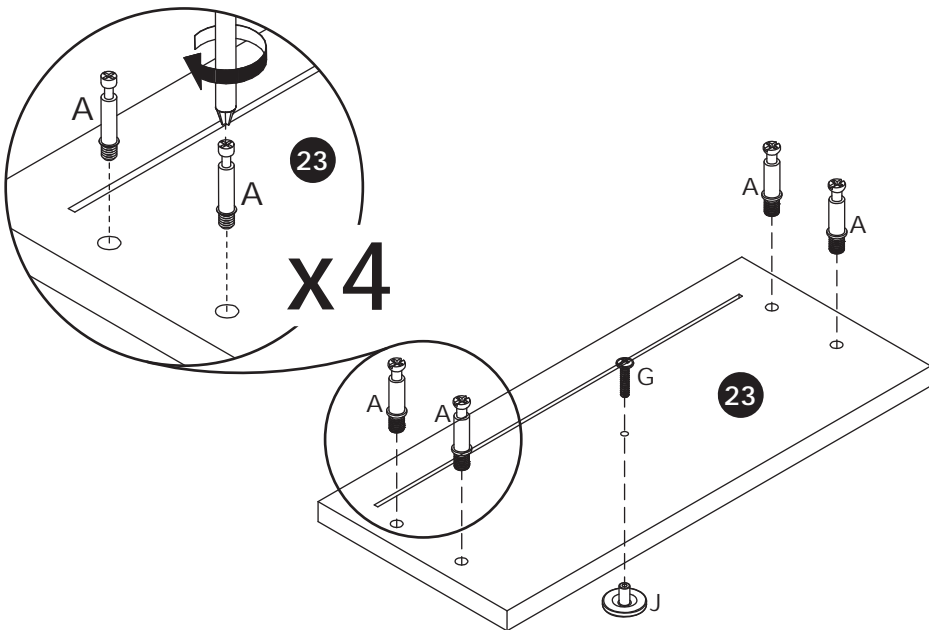
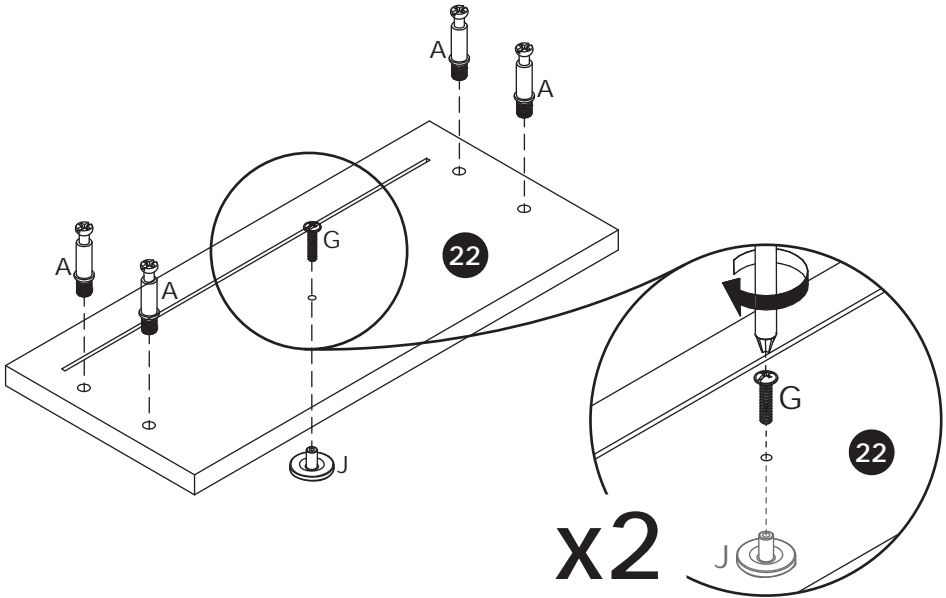
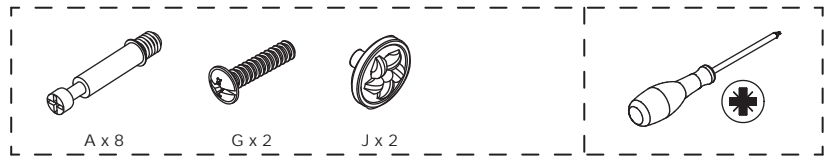

32



[EN] Slide panel 21 into the grooves.
Connect panels 22 and 23 to panels 18 and 19 respectively, and turn cam lock (B) to lock.

[ES] Deslice el panel 21 en las ranuras.
Conecte los paneles 22 y 23 a los paneles 18 y 19 respectivamente,
y gire el cierre excéntrico (B) para bloquearlo.

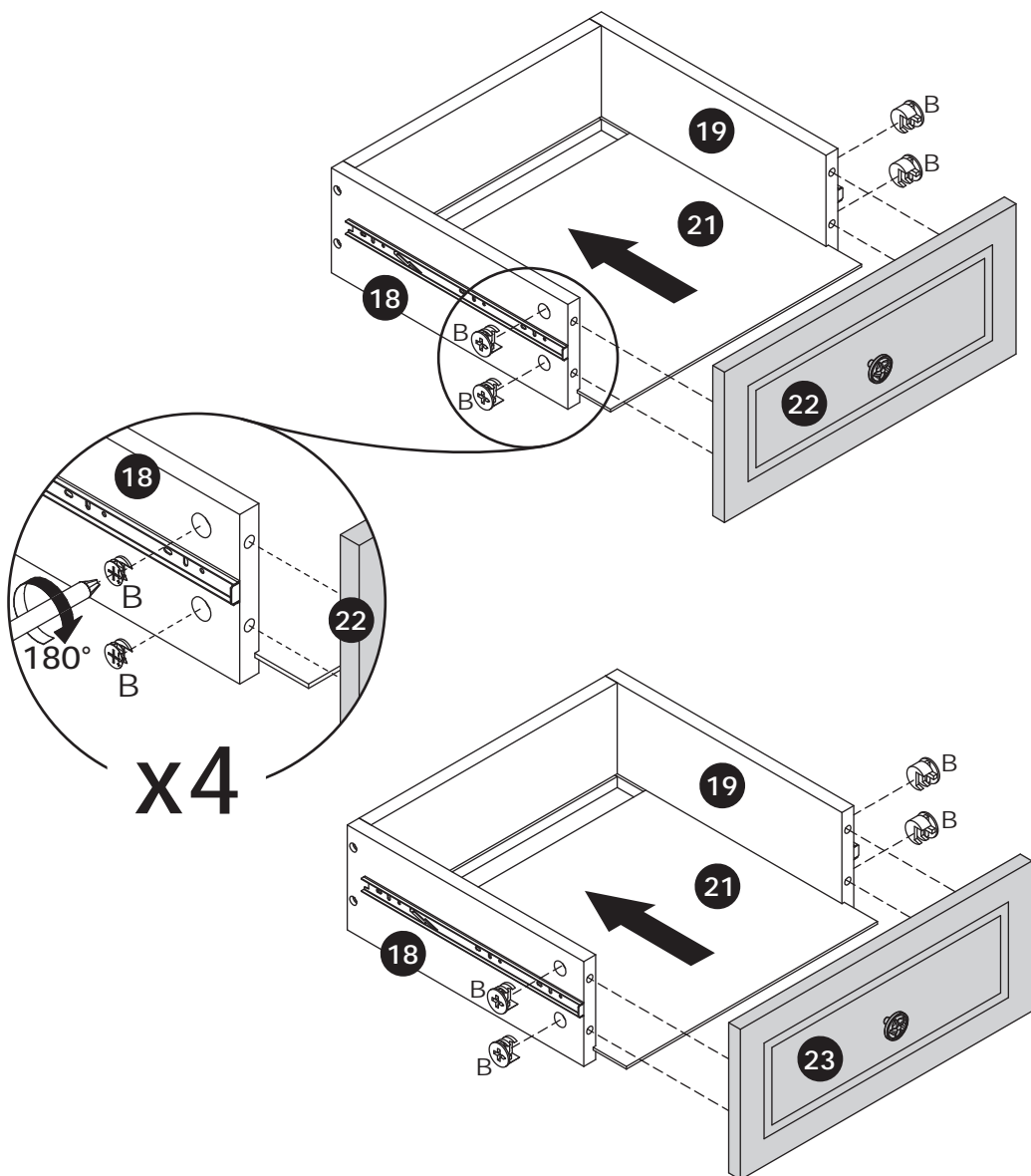

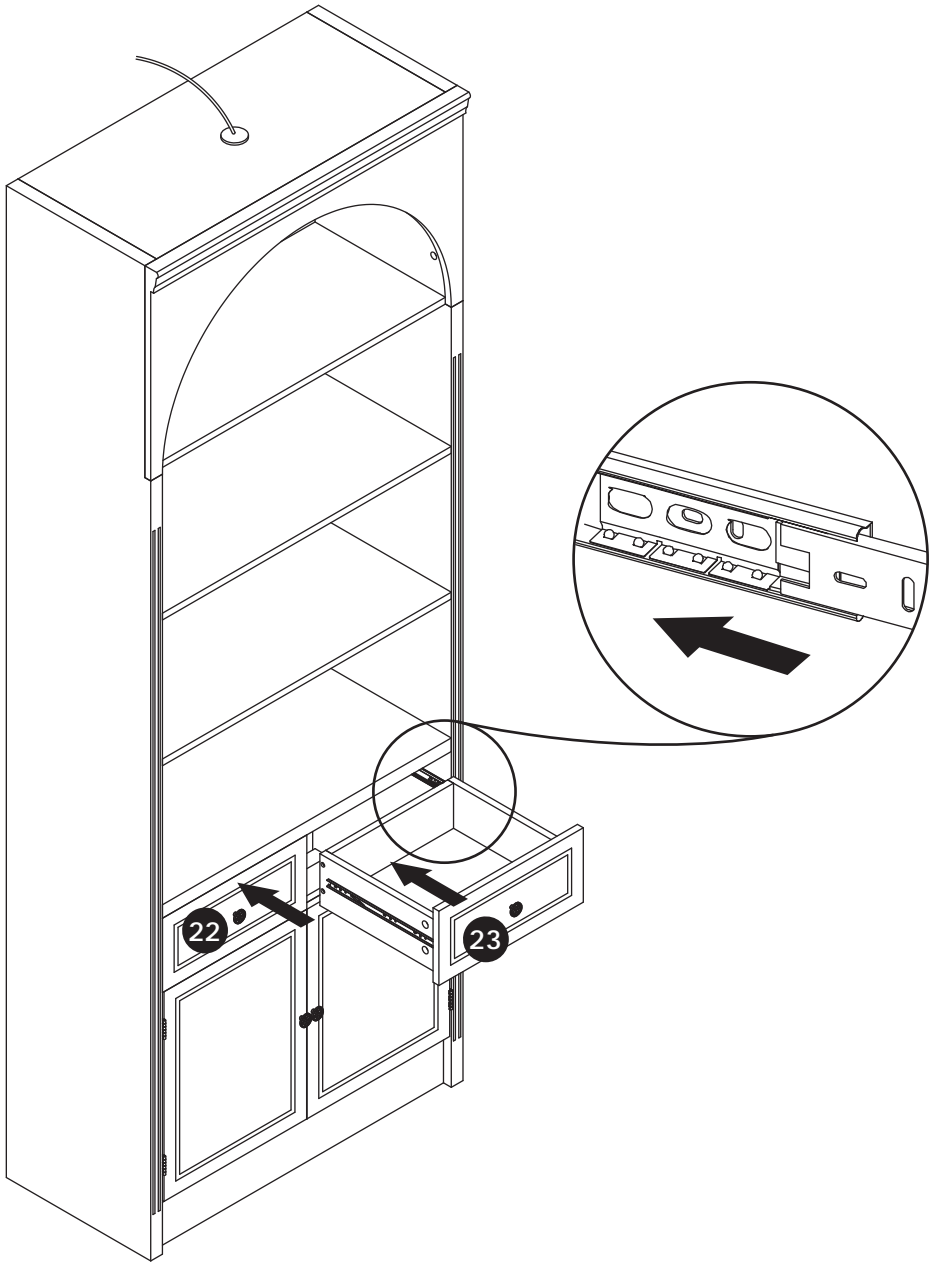

34

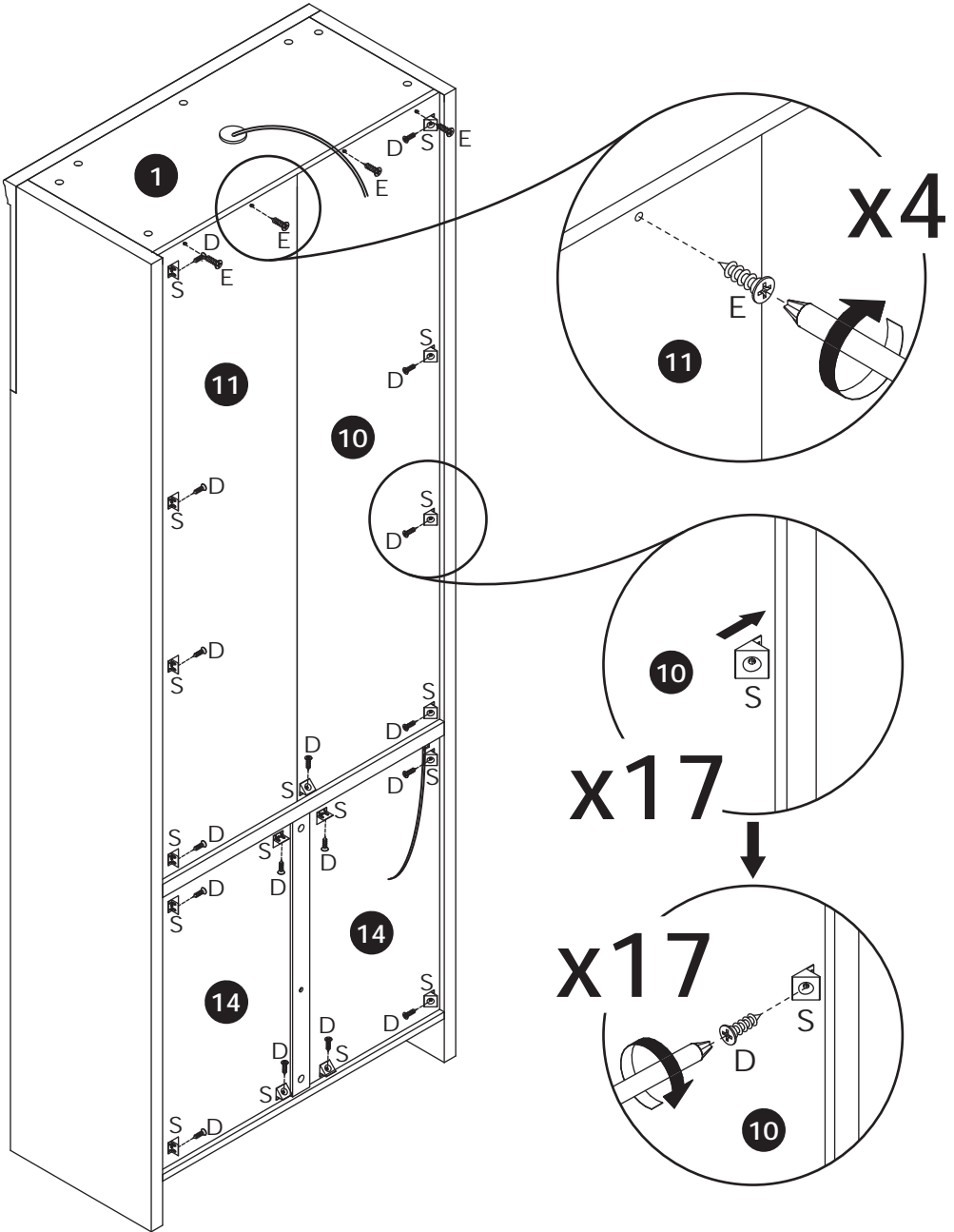
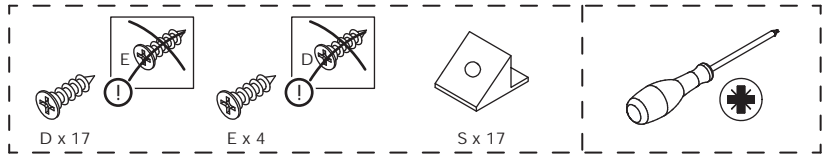

35

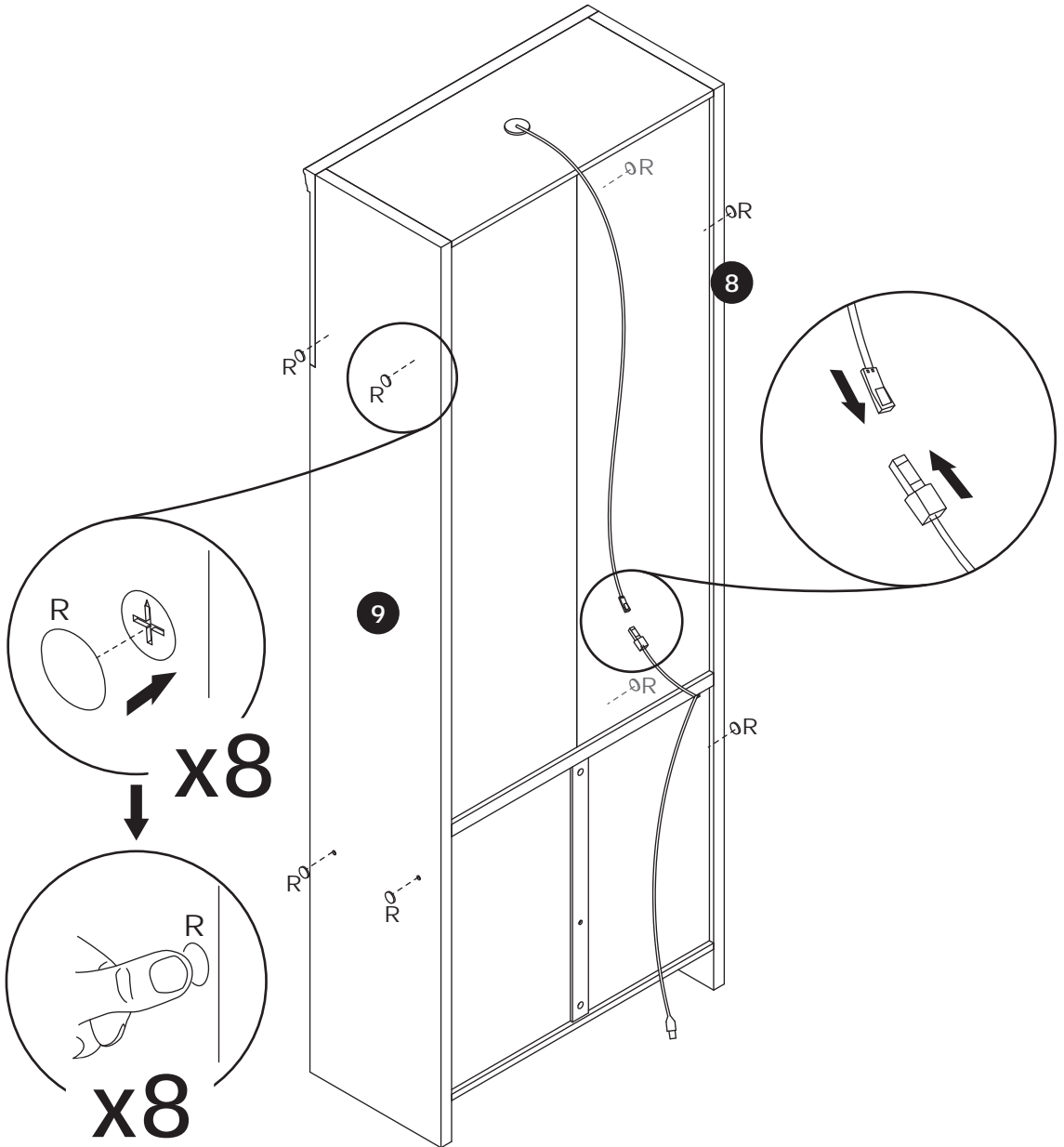

36



[EN] Install anti-tipping device as shown.

[ES] Instale el dispositivo antivuelco como se muestra.

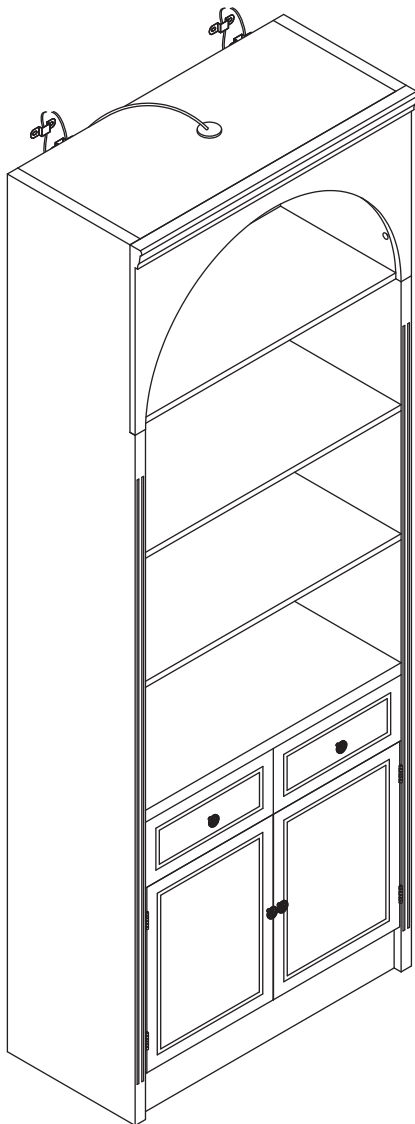
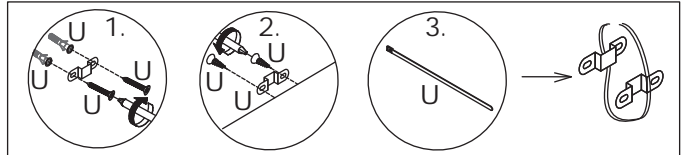

2 ADULTS

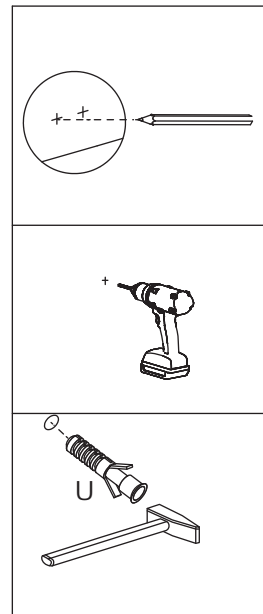

37

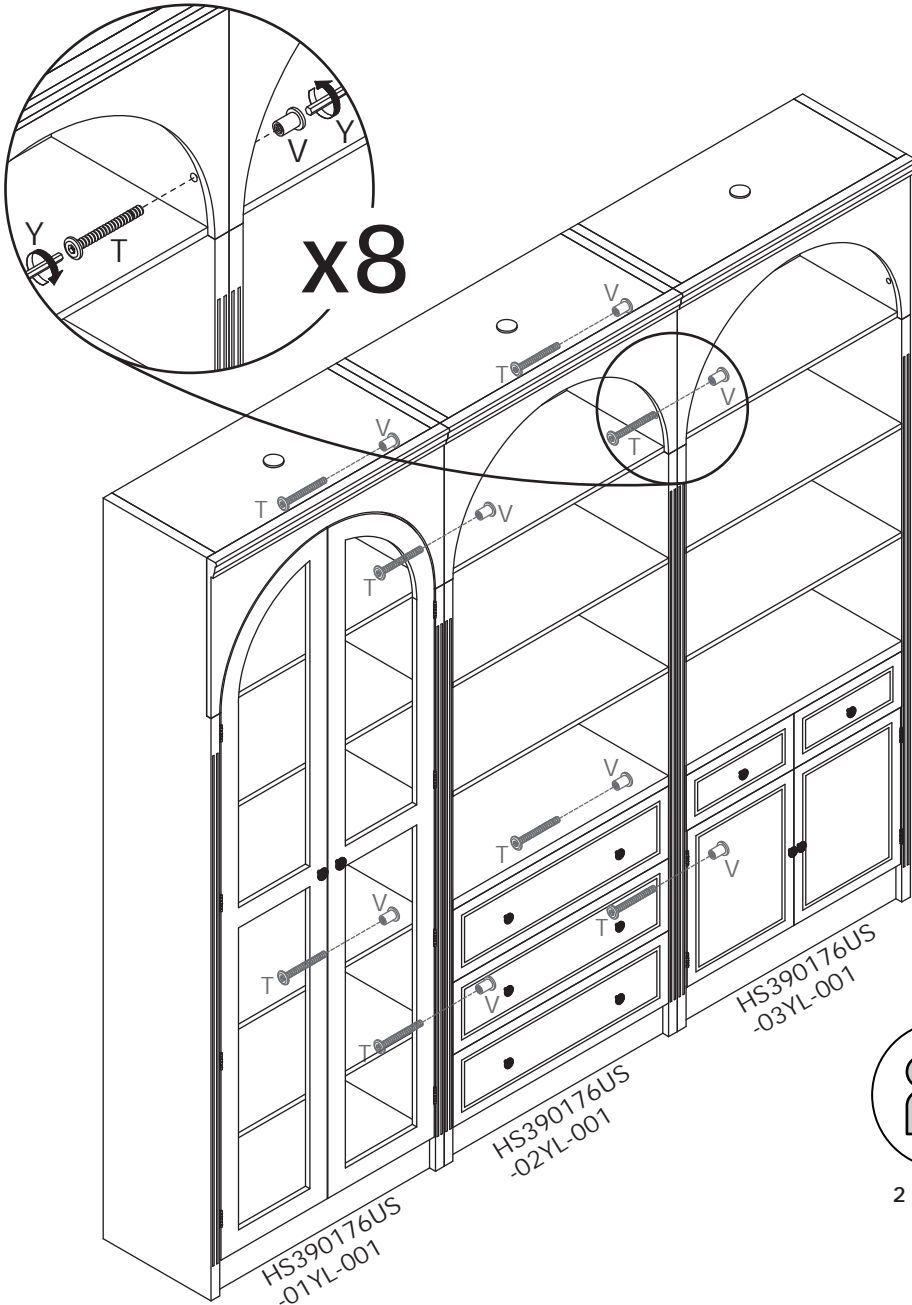

2 ADULTS

Should you have any problems assembling your product, contact us at customerservice@homsee.com. We're always happy to help! We have carefully selected the materials used in this product, and ask you to treat it responsibly too. Please recycle all packaging according to your local disposal rules.

Si tienes algún problema al ensamblar tu producto, contáctanos a customerservice@homsee.com. Siempre estaremos encantados de ayudarte. Hemos seleccionado cuidadosamente los materiales utilizados en este producto y te pedimos que también lo trates de manera responsable. Por favor, recicla todo el embalaje de acuerdo con las normas locales de eliminación de residuos.

