

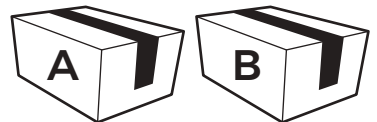

ASSEMBLY INSTRUCTIONS

DESIGN BY HOMSEE
VERSION: HS390172US-YQ-001



i This product comes in 2 packages



One of the unique features of Homsee furniture is its versatility. Designed with the idea of customization in mind, our products can be easily linked together to create seamless, personalized setups that fit your specific needs.

For instance, if you purchase a couple of our shelves, you can effortlessly combine them to form a larger, unified structure. This modular approach allows you to expand, rearrange, and adapt your furniture as your space and style evolve. Whether you're looking to create a vast shelving system, or a continuous storage solution, the possibilities are endless.

At Homsee, we empower you to create a space that is truly yours—one that grows with you, all while maintaining a sleek, cohesive look.



Una de las características distintivas del mobiliario Homsee es su versatilidad. Diseñados pensando en la personalización, nuestros productos pueden conectarse fácilmente entre sí para crear configuraciones continuas y personalizadas que se ajusten a tus necesidades específicas.

Por ejemplo, si compras un par de nuestras estanterías, puedes combinarlas sin esfuerzo para formar una estructura más grande y unificada. Este enfoque modular te permite ampliar, reorganizar y adaptar tus muebles a medida que evolucionan tu espacio y tu estilo. Ya sea que busques crear un amplio sistema de estanterías o una solución de almacenamiento continua, las posibilidades son infinitas.

En Homsee, te ayudamos a crear un espacio verdaderamente tuyo—uno que crece contigo, manteniendo a la vez un aspecto elegante y coherente.



IMPORTANT INFORMATION!

Please read the entire manual before starting to assembling or using this product. Follow the manual thoroughly and keep it for further reference.

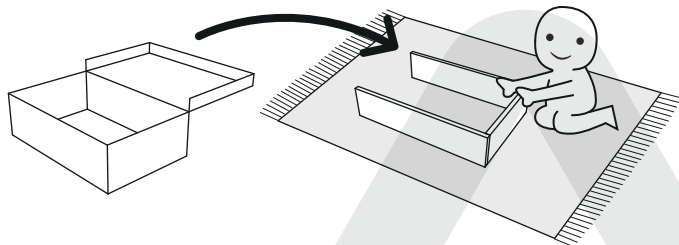

AVOID SCRATCHES!

In order to avoid scratching the furniture should be assembled on a soft layer—could be a rug.

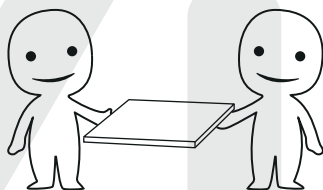

IMPROVE ASSEMBLY EFFICIENCY !

Try to find a partner to install with you, which can speed up the installation efficiency and shorten the time.

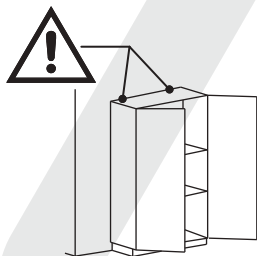

ANTI-TOPPLE WARNING !

Overturned furniture can cause serious or fatal crush injuries. To prevent tipping, be sure to use a wall-anchoring attachment. If one is not included with this product, please purchase a suitable attachment that fits your wall. If unsure, seek professional advice. Please read and follow all instructions carefully.

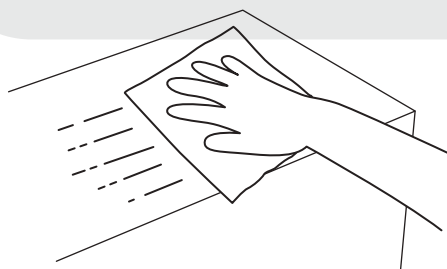

MAINTENANCE AND CLEANING !

For regular maintenance and cleaning, use a rag dipped in neutral detergent to wipe the frame thoroughly, and then dry it with a clean rag. For glass surfaces, wipe with a rag dampened with water or glass cleaner, and then dry with a clean, dry cloth.

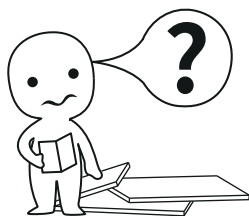

¡INFORMACIÓN IMPORTANTE!

Por favor, lee todo el manual antes de comenzar a ensamblar o usar este producto. Sigue las instrucciones detenidamente y consérvalo para futuras consultas.

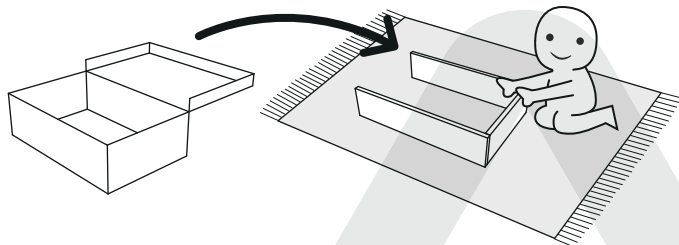

¡EVITA LOS RAYONES!

Para evitar que el mueble se raye, debe ensamblarse sobre una superficie suave, como una alfombra.

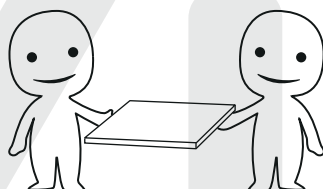

¡MEJORA LA EFICIENCIA!

Intenta encontrar a alguien que te ayude con la instalación; trabajar en pareja puede aumentar la eficiencia y reducir el tiempo de montaje.

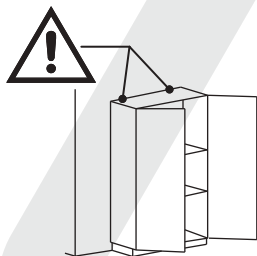

¡ADVERTENCIA ANTIVUELCO!

El mobiliario volcado puede causar lesiones graves o incluso mortales por aplastamiento. Para evitar que se vuelque, asegúrate de utilizar el sistema de anclaje a la pared. Si este producto no lo incluye, adquiere un anclaje compatible con tu pared. Si no estás seguro de cuál usar, busca asesoramiento profesional. Lee y sigue cuidadosamente cada paso de las instrucciones.

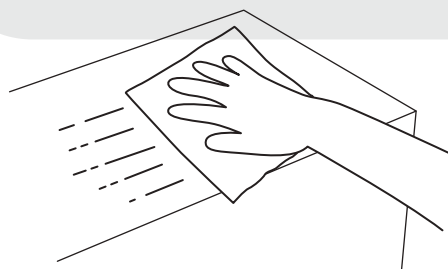

¡MANTENIMIENTO Y LIMPIEZA!

Para el mantenimiento y la limpieza regulares del producto, limpia el marco con un paño humedecido en un detergente neutro y luego sécalo con un paño limpio. Para los materiales de vidrio, límpialos con un paño humedecido en limpiador de vidrios con agua y luego sécalos con un paño seco.



The following are common installation steps. Correct operation is required to avoid product damage.

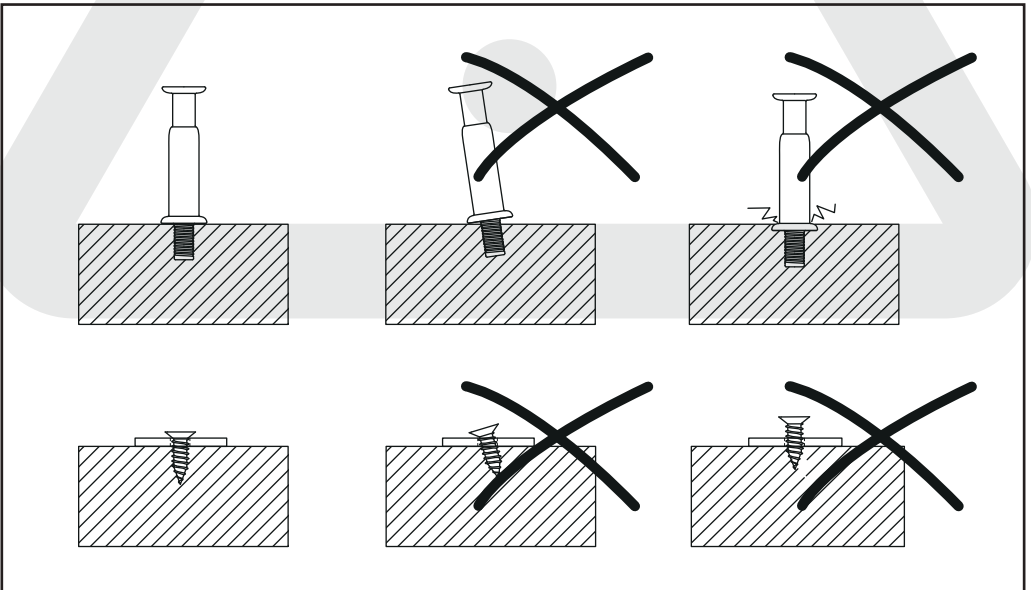
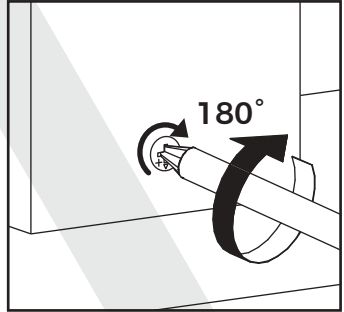
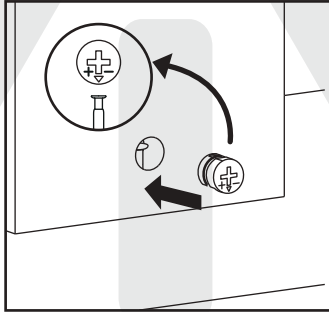
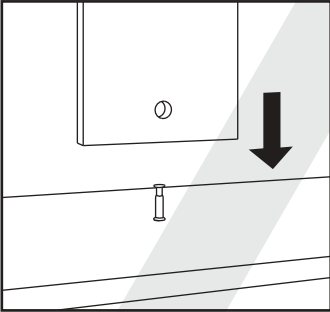
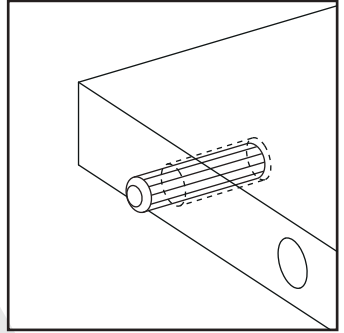
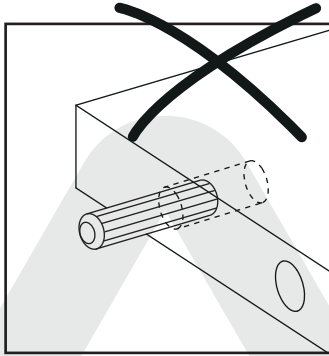
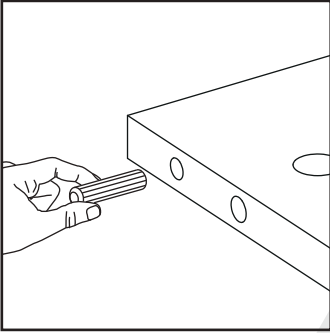



Los siguientes pasos de instalación son bastante comunes y requieren una operación correcta durante el proceso de montaje. El uso incorrecto puede dañar el mueble.

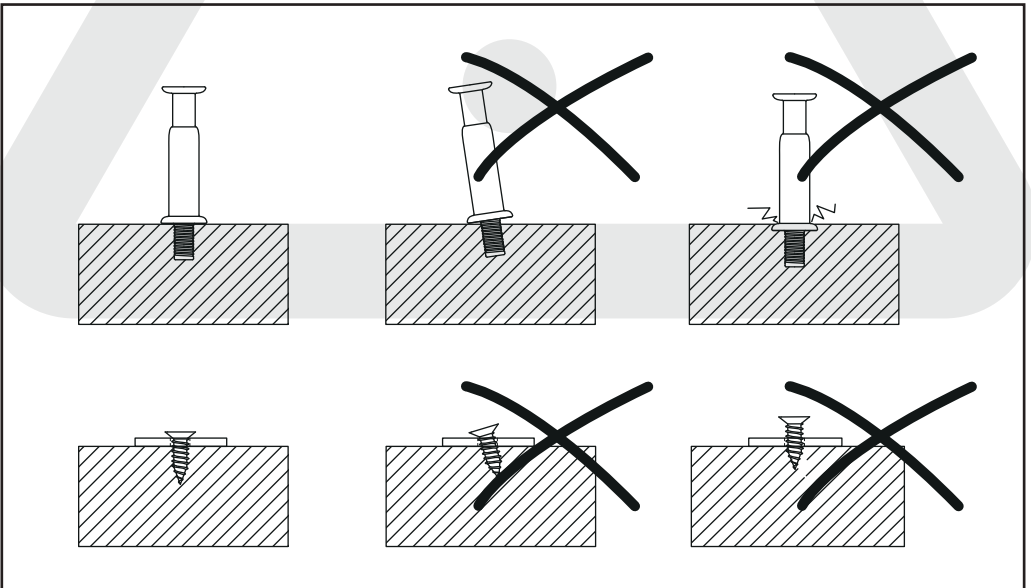
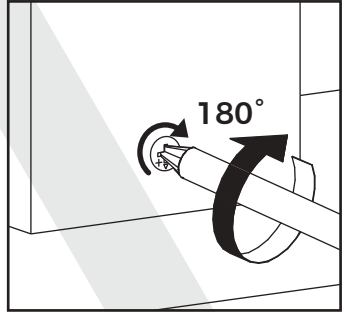
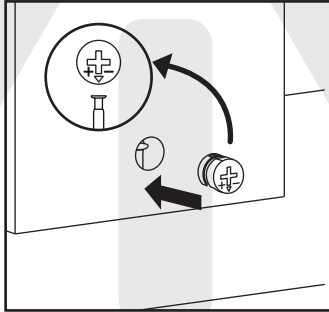
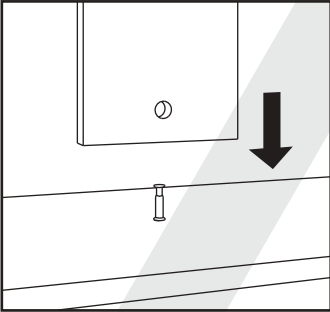
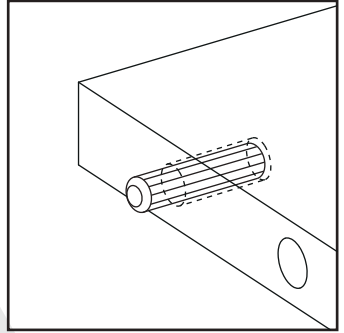
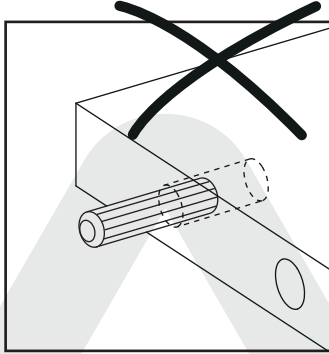
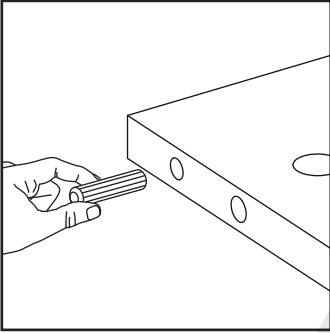



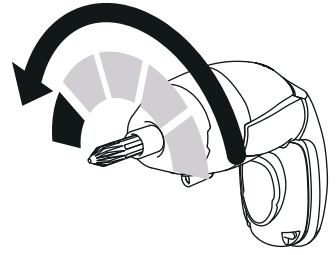
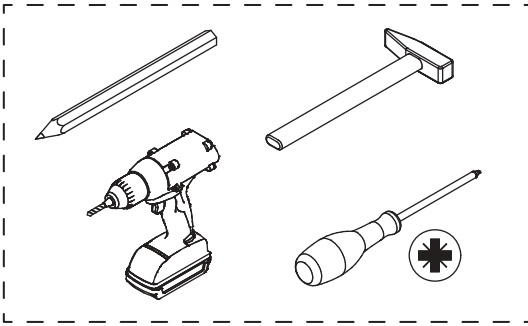









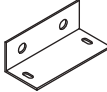
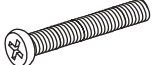

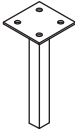

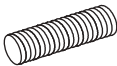
Please prepare the following tools



If you choose to use power tools, set them to a low-power setting. Use caution—power tools may crack or damage the furniture and can also harm the hardware.

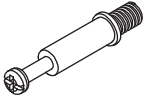

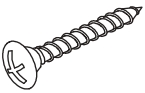
Some accessories have similar shapes, please distinguish them according to their numbers and sizes during installation.

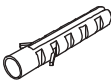
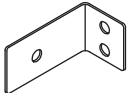
<p>A x 20</p>  <p>M5 x 10 mm</p>	<p>B x 4</p>  <p>M3 x 6 mm</p>	<p>C x 2</p> 	<p>D x 2</p> 	<p>E x 22</p>  <p>M6 x 30 mm</p>
<p>F x 18</p>  <p>M4 x 12 mm</p>	<p>G x 1</p> 	<p>H x 20</p>  <p>M6 x 10 mm</p>	<p>I x 4</p>  <p>M6 x 25 mm</p>	<p>J x 4</p> 
<p>K x 2</p>  <p>M6 x 30 mm</p>	<p>L x 4</p>  <p>M4 x 40 mm</p>	<p>M x 5</p>  <p>M6</p>	<p>N x 1</p> 	<p>O x 2</p>  <p>M6 x 35 mm</p>
<p>P x 2</p>  <p>∅15 x 10 mm</p>	<p>Q x 10</p>  <p>M5 x 30 mm</p>	<p>R x 16</p> 	<p>S x 2</p>  <p>∅6 x 35 mm</p>	<p>T x 2</p> 



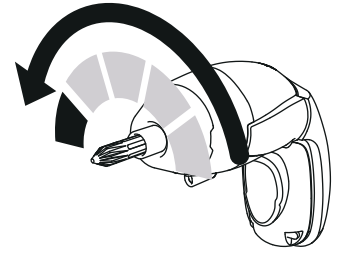
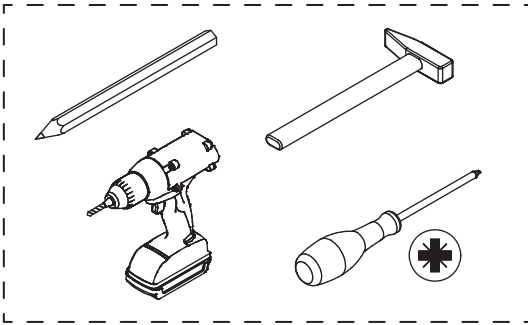









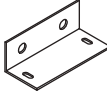
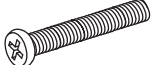

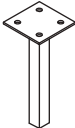
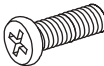
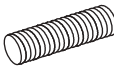
Por favor, prepara las siguientes herramientas



Si decides utilizar herramientas eléctricas, ajústalas a una velocidad baja. ¡Ten cuidado! Las herramientas eléctricas pueden causar grietas o daños en el mueble, y también pueden dañar los herrajes.

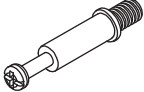

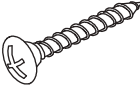
Algunos accesorios tienen la misma forma; por favor, distíngalos según sus números y tamaños durante la instalación.

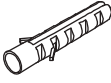
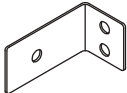
<p>A x 20</p>  <p>M5 x 10 mm</p>	<p>B x 4</p>  <p>M3 x 6 mm</p>	<p>C x 2</p> 	<p>D x 2</p> 	<p>E x 22</p>  <p>M6 x 30 mm</p>
<p>F x 18</p>  <p>M4 x 12 mm</p>	<p>G x 1</p> 	<p>H x 20</p>  <p>M6 x 10 mm</p>	<p>I x 4</p>  <p>M6 x 25 mm</p>	<p>J x 4</p> 
<p>K x 2</p>  <p>M6 x 30 mm</p>	<p>L x 4</p>  <p>M4 x 40 mm</p>	<p>M x 5</p>  <p>M6</p>	<p>N x 1</p> 	<p>O x 2</p>  <p>M6 x 35 mm</p>
<p>P x 2</p>  <p>Ø15 x 10 mm</p>	<p>Q x 10</p>  <p>M5 x 30 mm</p>	<p>R x 16</p> 	<p>S x 2</p>  <p>Ø6 x 35 mm</p>	<p>T x 2</p> 

Parts List

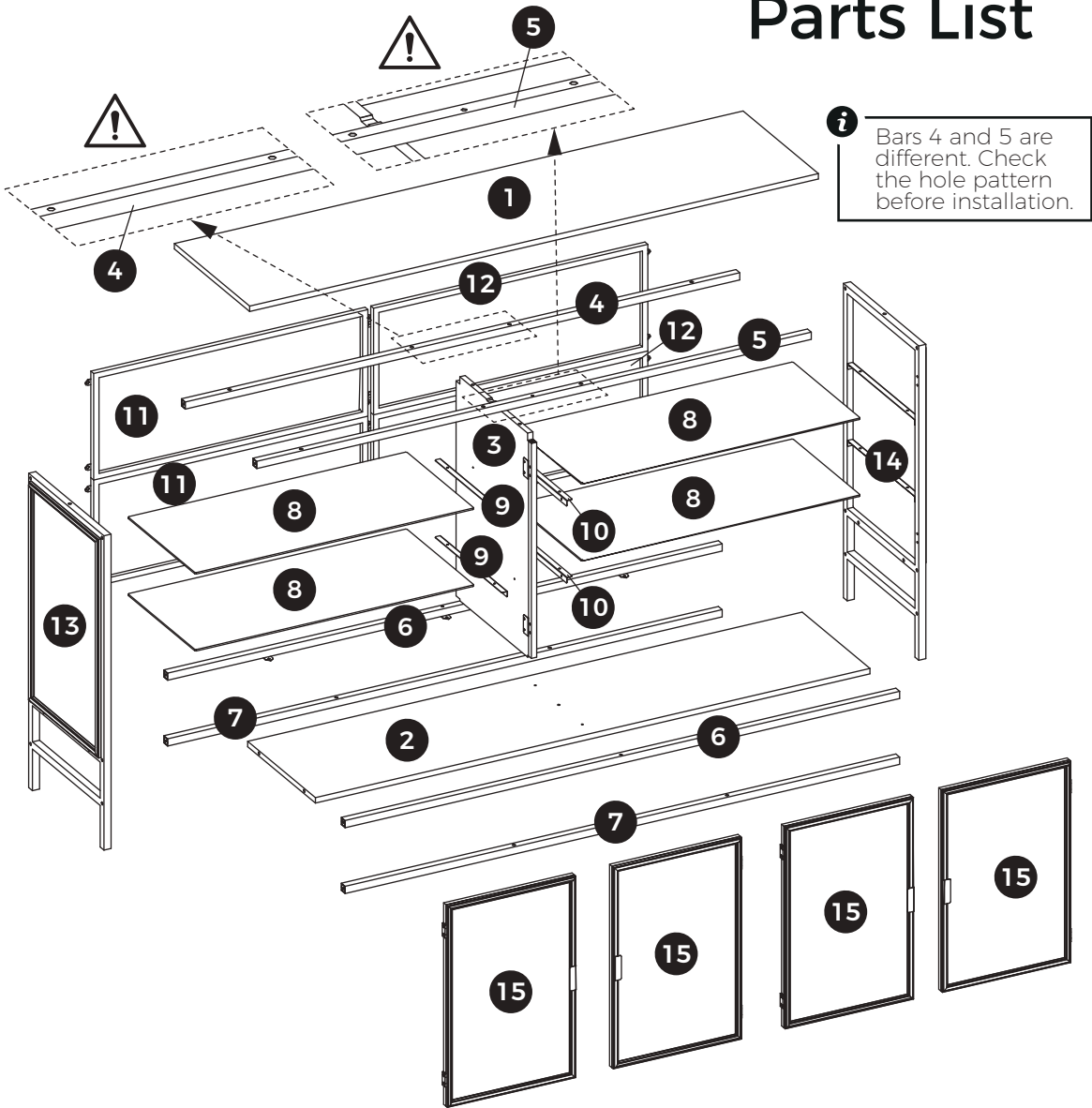

WARNING

Children have died from furniture tipover. To reduce the risk of furniture tipover:

- ALWAYS install Anti-tip device provided
- NEVER put a TV on this product.
- NEVER allow children to stand, climb or hang on drawers, doors, or shelves.
- NEVER open more than one drawer at a time.
- Place heaviest items in the lowest drawers.

This is a permanent label. Do not remove!



60 MINUTES



2 ADULTS



INTERMEDIATE

The parts listed above are required for proper assembly. If there are any issues. Contact us: customerservice@homsee.com

Lista de Piezas

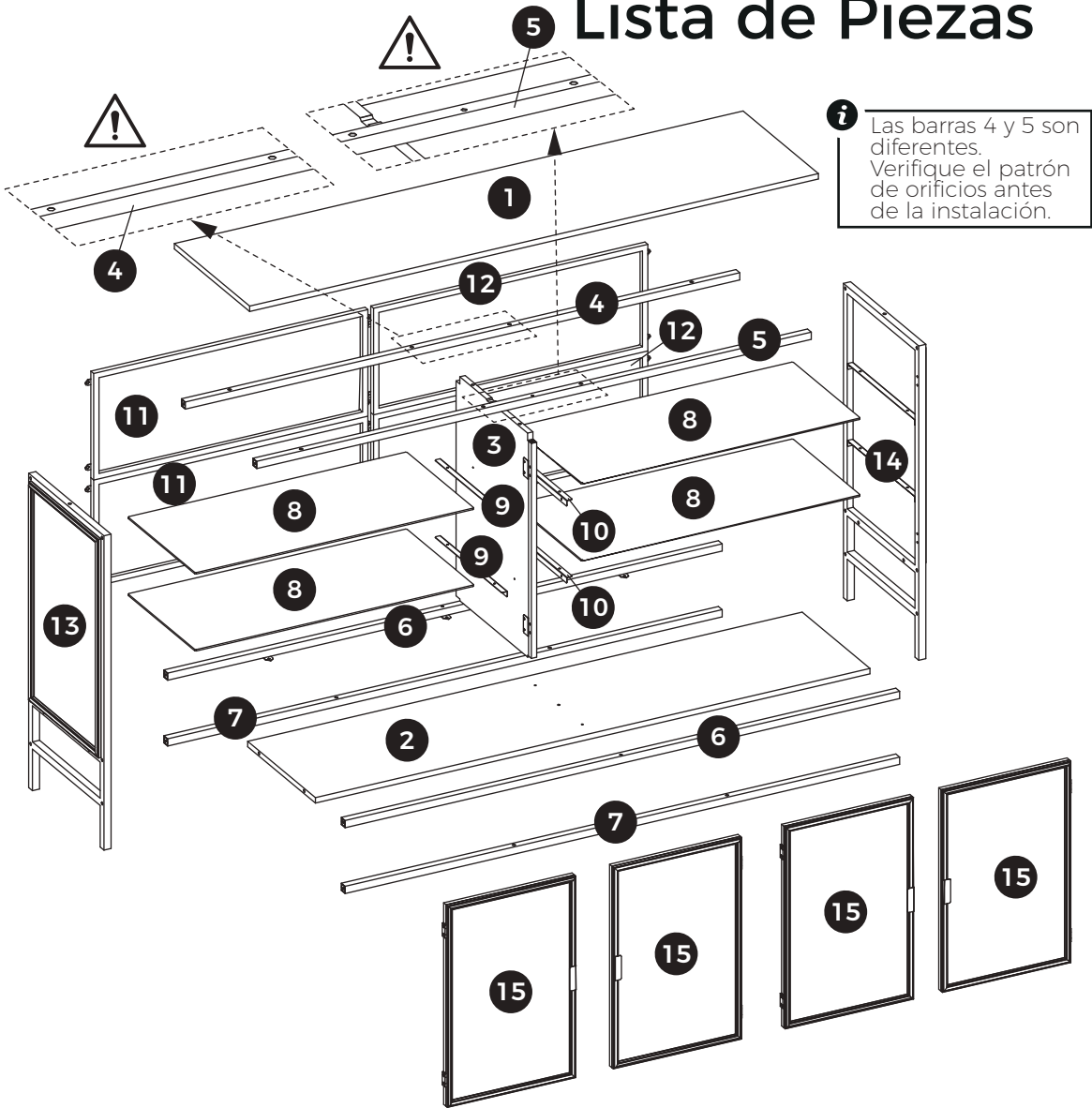

i Las barras 4 y 5 son diferentes. Verifique el patrón de orificios antes de la instalación.

⚠ ADVERTENCIA

Los niños han muerto por el vuelco de muebles. Para reducir el riesgo de que el mueble se vuelque:

- SIEMPRE instala el dispositivo antivuelco incluido.
- NUNCA coloques un televisor sobre este producto.
- NUNCA permitas que los niños se suban, trepen o cuelguen de los cajones, puertas o estantes.
- NUNCA abras más de un cajón a la vez.
- Coloca los objetos más pesados en los cajones inferiores.

Esta es una etiqueta permanente. ¡No la retires!



60 MINUTOS



2 ADULTOS



INTERMEDIO

Las piezas enumeradas arriba son necesarias para un montaje correcto. Si tienes algún problema, contáctanos en: customerservice@homsee.com



Cut out this page for easy viewing during subsequent installation.

Recorte esta página para poder consultarla fácilmente durante la instalación posterior.

Parts List

Lista de Piezas



BOX 1/2
CAJA 1/2

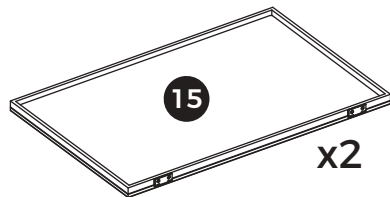
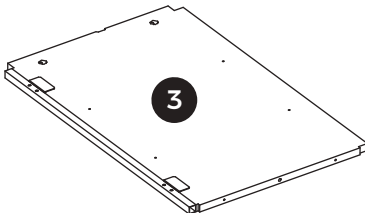
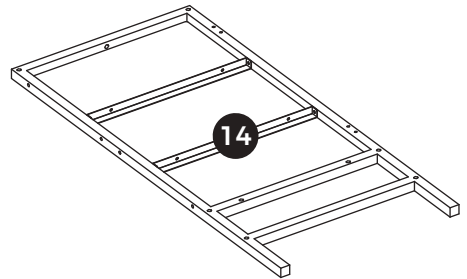
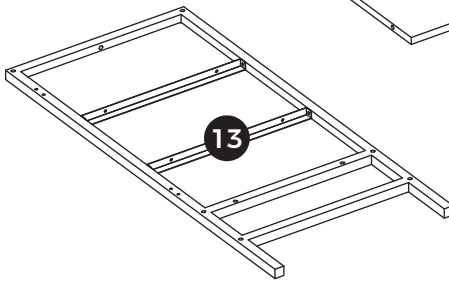
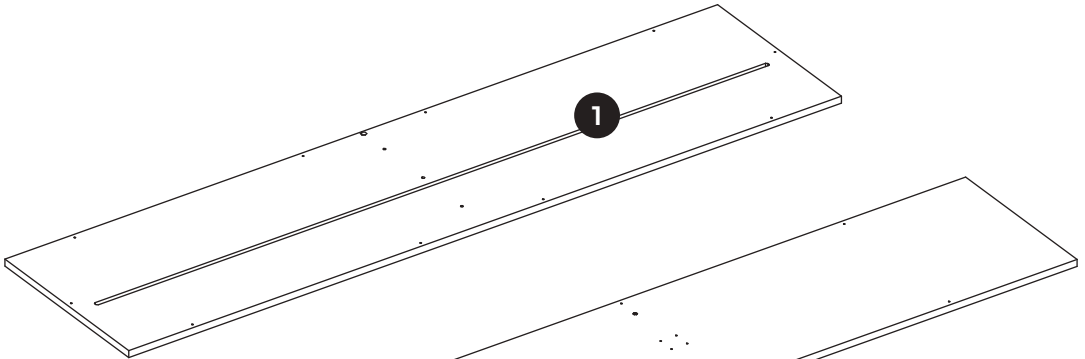

x2

Parts List

Lista de Piezas

Cut out this page for easy viewing during subsequent installation.

Recorte esta página para poder consultarla fácilmente durante la instalación posterior.

BOX 2/2
CAJA 2/2

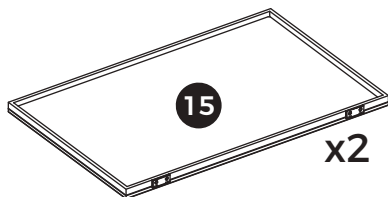
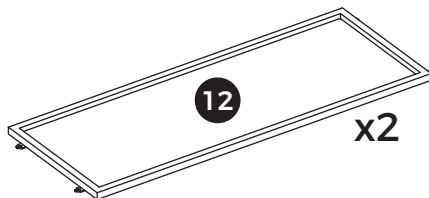
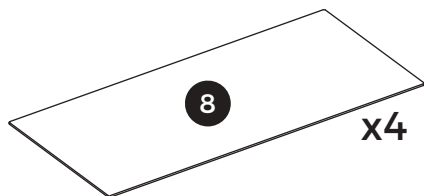
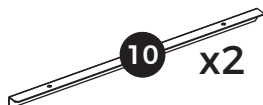
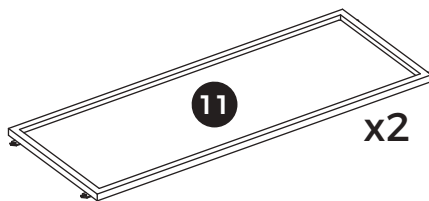
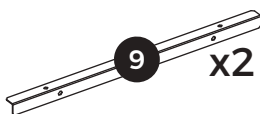
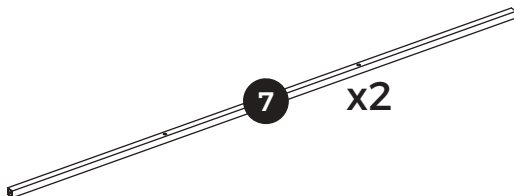
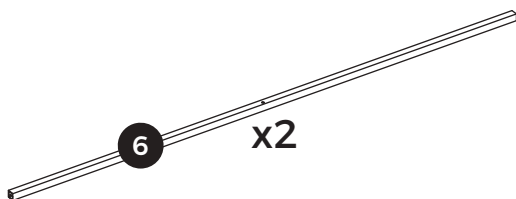
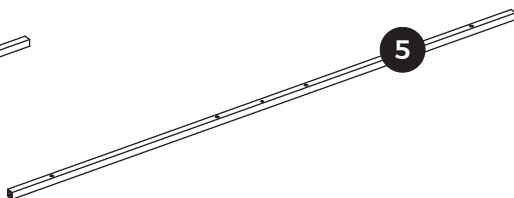
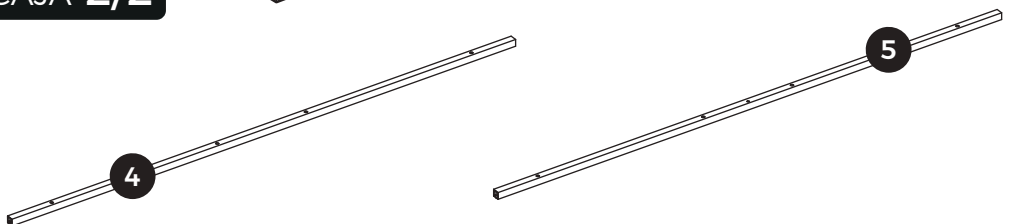
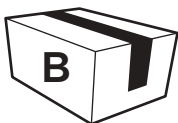

01

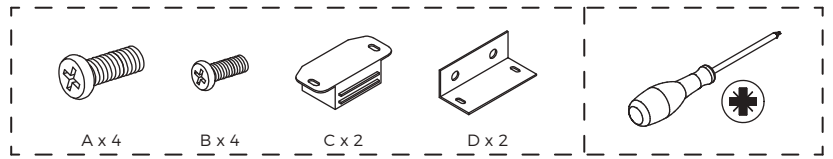

[EN] Secure angle brackets (D) to metal bar 5 using screws (A).
Then secure magnets (C) to angle brackets using screws (B).

[ES] Fije los soportes angulares (D) a la barra metálica 5 utilizando los tornillos (A). Luego fije los imanes (C) a los soportes angulares utilizando los tornillos (B).

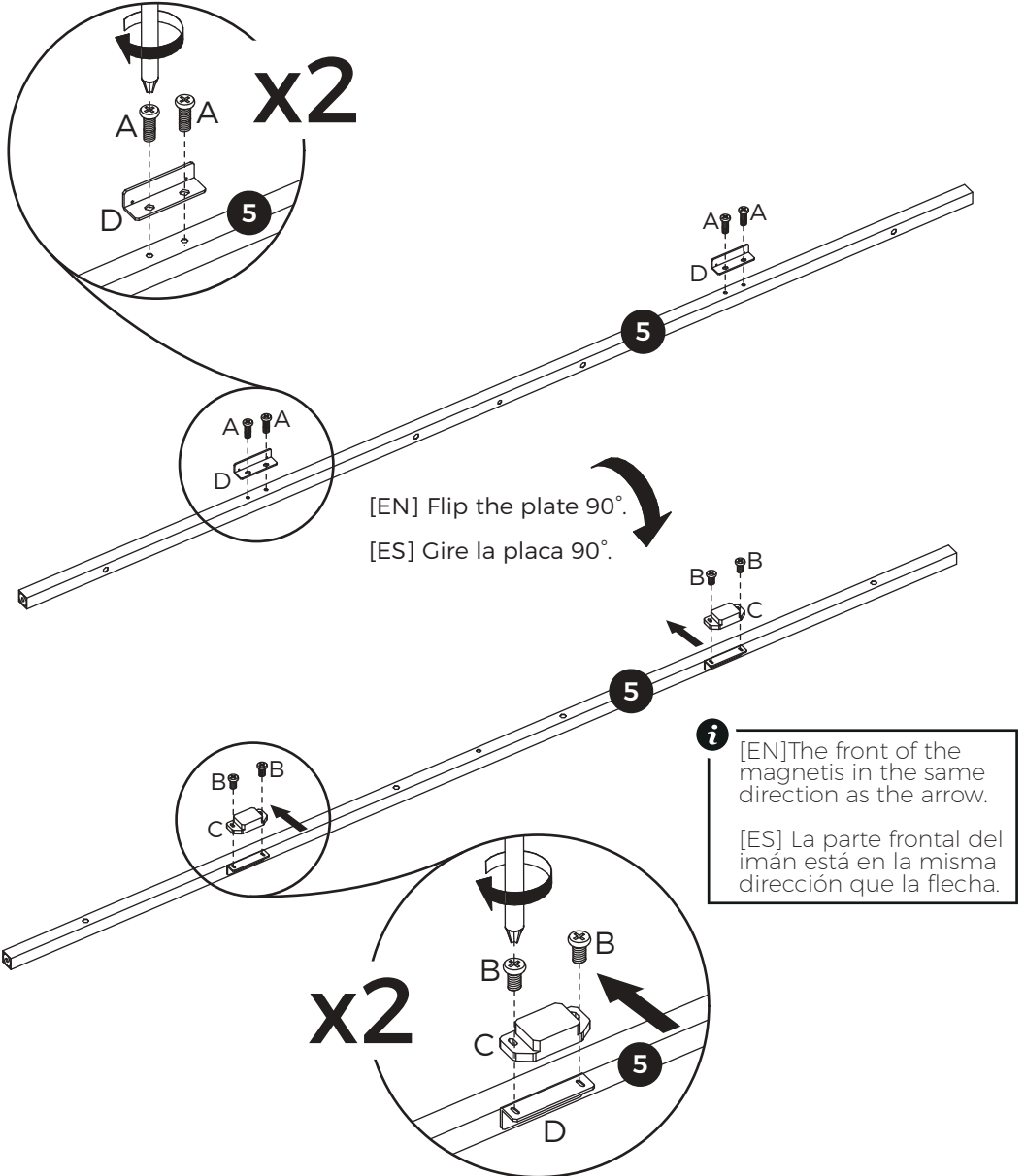

02



Ex 4

[EN] Connect metal frames 13 and 14 to metal bars 4 and 5 using screws (E).

[ES] Conecte los marcos metálicos 13 y 14 a las barras metálicas 4 y 5 utilizando los tornillos (E).

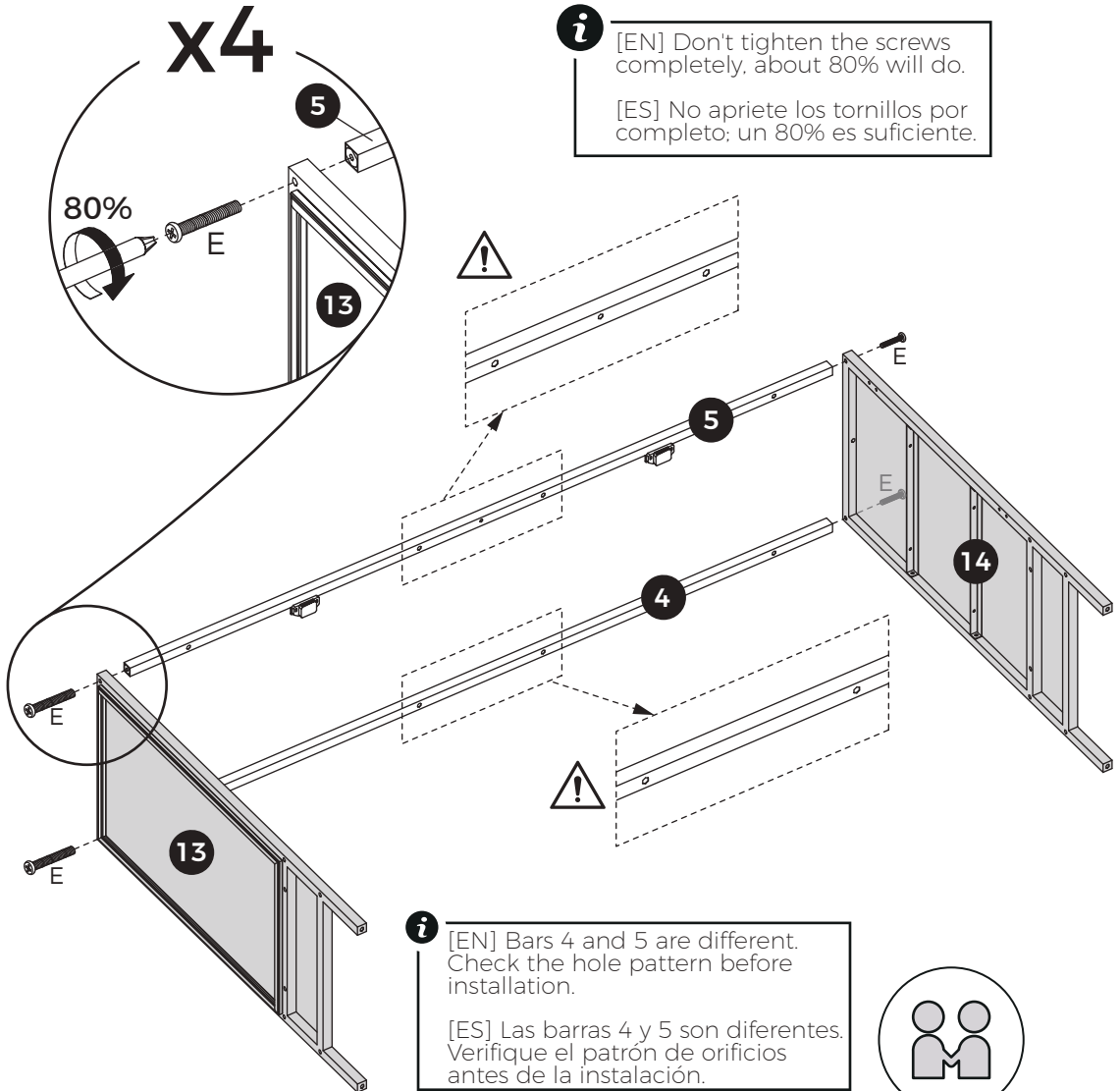

2 ADULTS

03



[EN] Secure angle brackets 9 and 10 to plate 3 using screws (F).

[ES] Fije los soportes angulares 9 y 10 al panel 3 utilizando los tornillos (F).

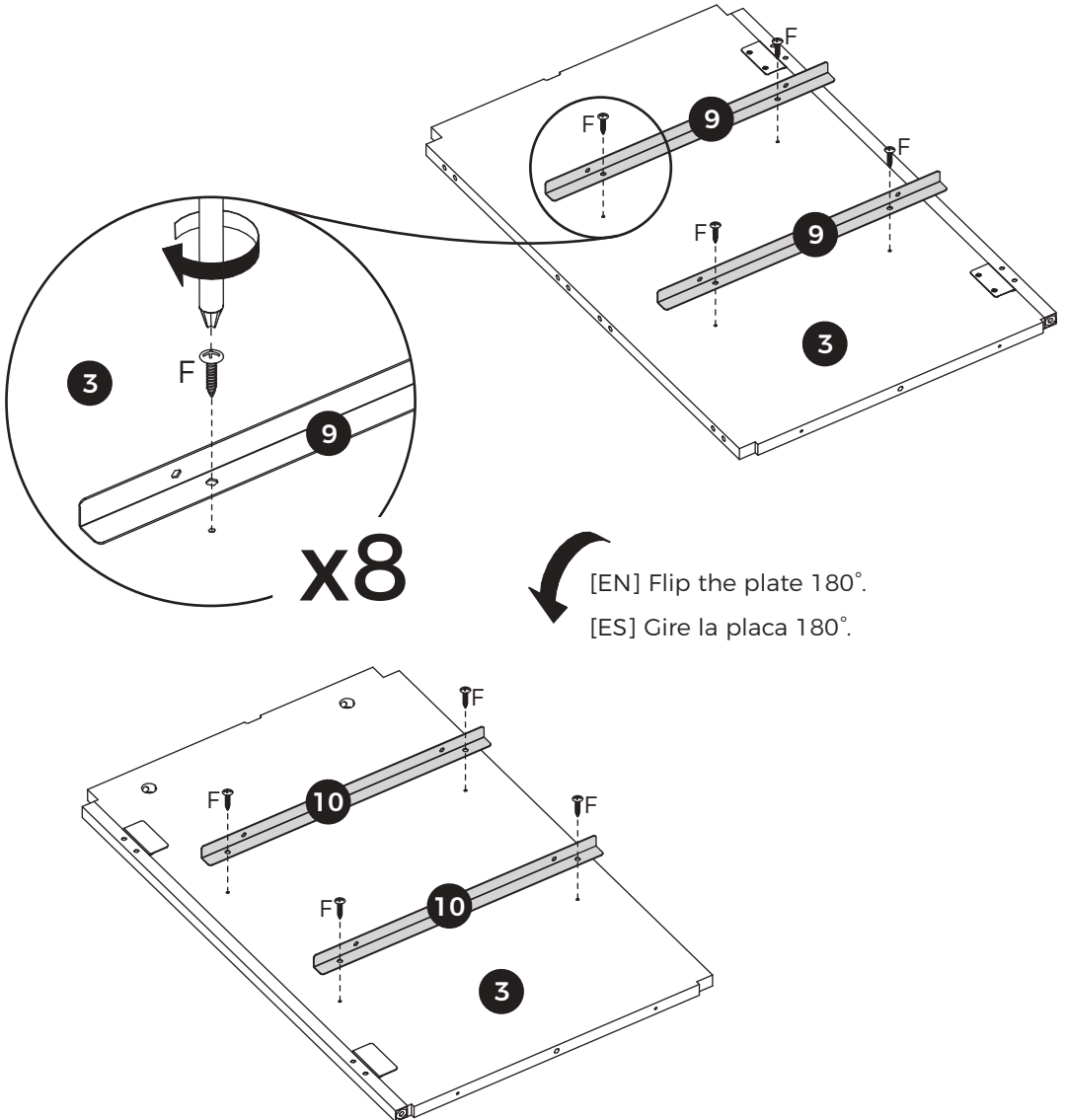

04



[EN] Secure metal bar 5 to plate 3 using screw (E).

[ES] Fije la barra metálica 5 a la placa 3 utilizando el tornillo (E).

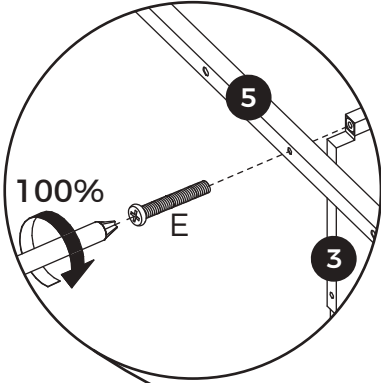

[EN] Tighten this screw to 100%.

[ES] Apriete este tornillo al 100%.

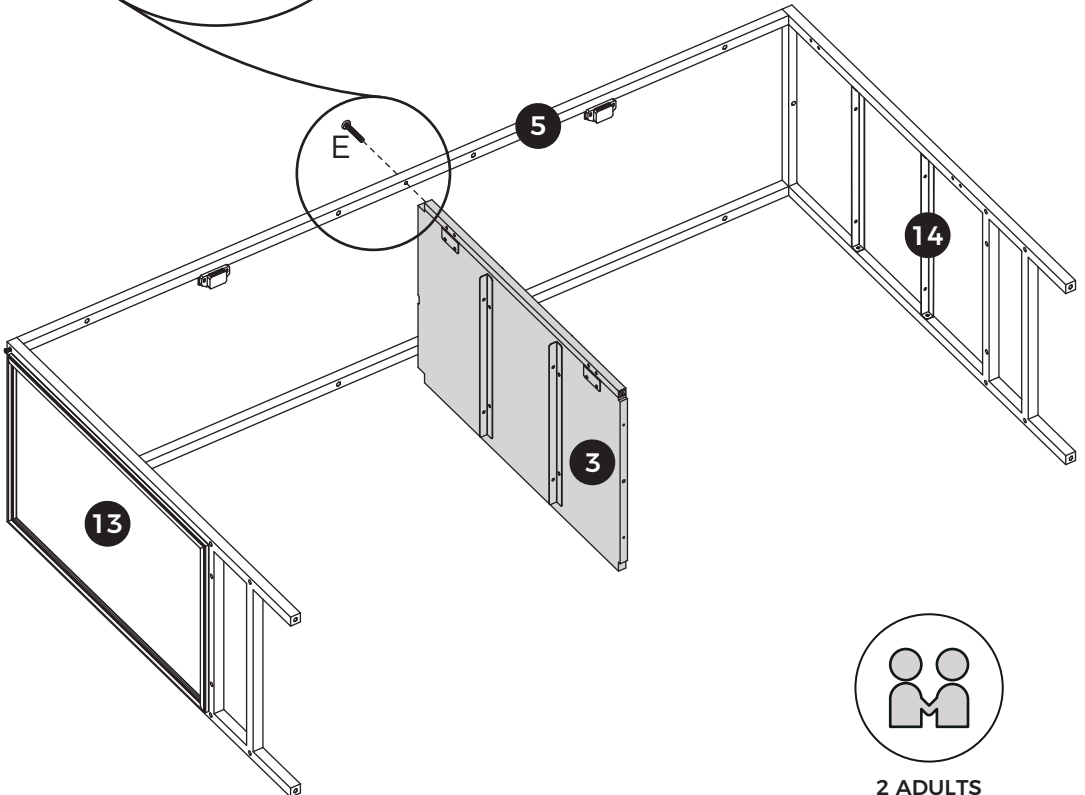

2 ADULTS

05



[EN] Secure metal bars 6 to plate 2 using screws (F).

[ES] Fije las barras metálicas 6 al panel 2 usando los tornillos (F).

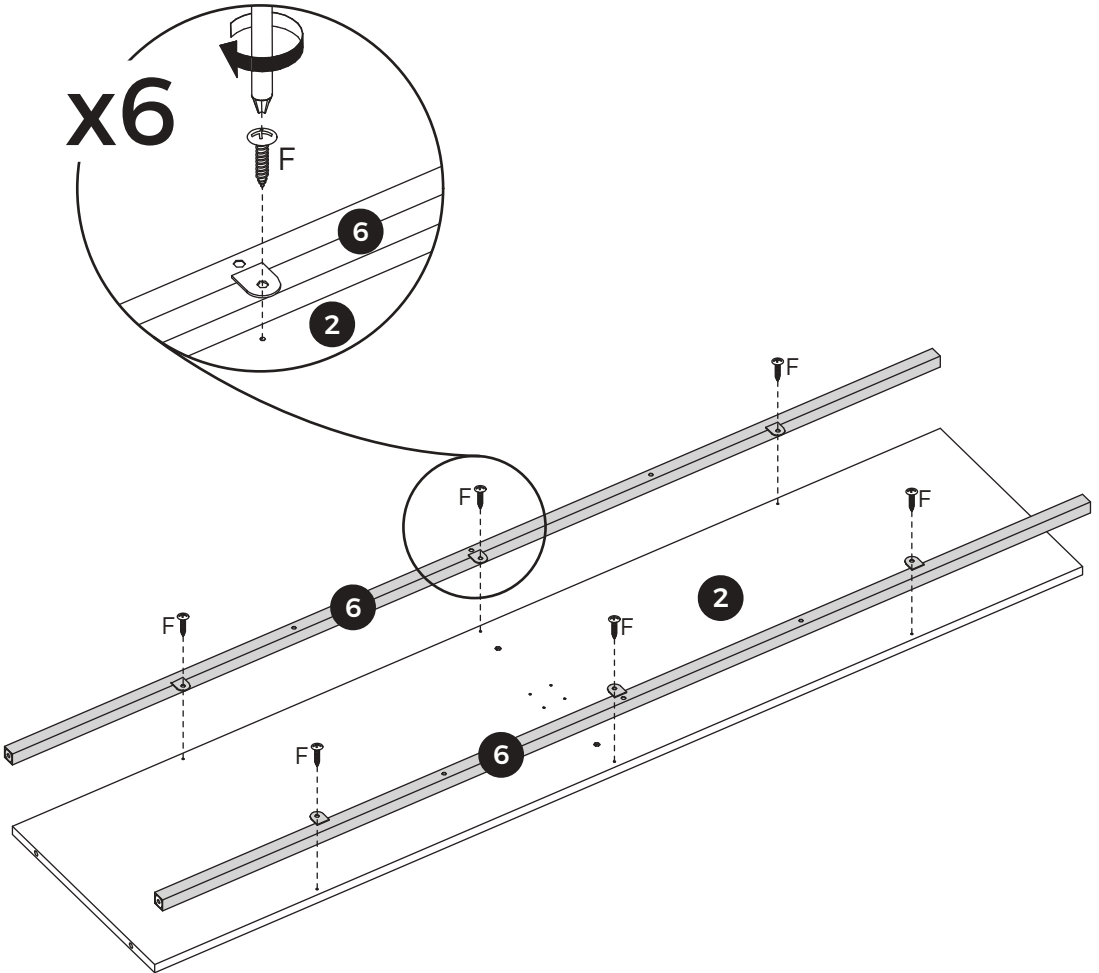

06



[EN] Secure leg support (G) to plate 2 using screws (H).

[ES] Fije el soporte de pata (G) al panel 2 usando los tornillos (H).

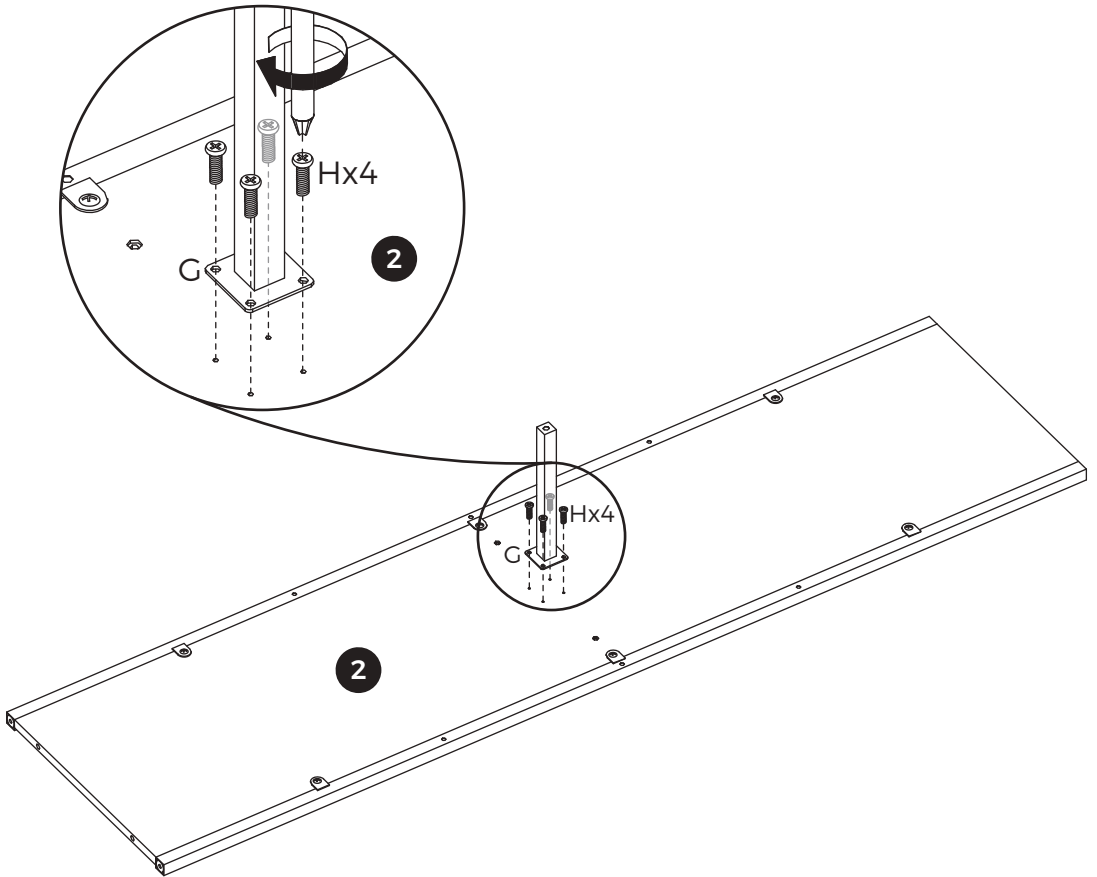

07



[EN] Twist screws (l) into plate 2.

[ES] Enrosque los tornillos (l) en el panel 2.

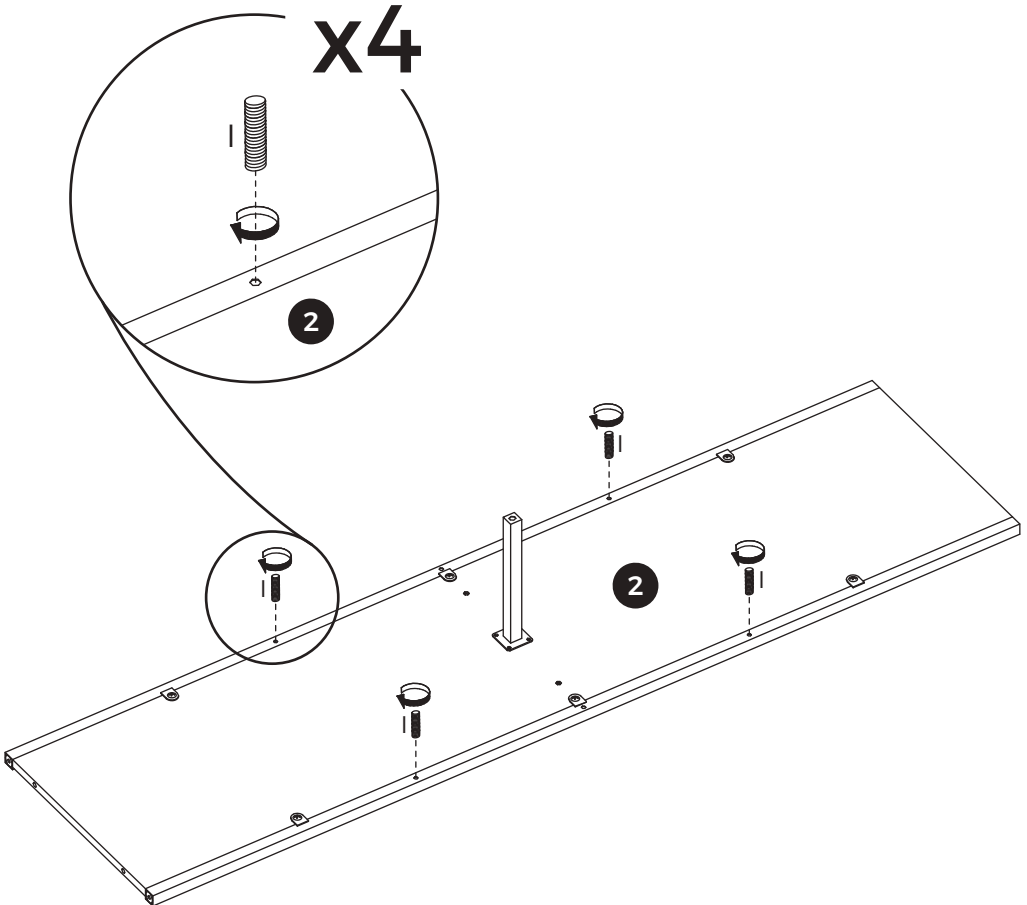

08



[EN]Screw metal bars (J) onto screws (I).

[ES]Enrosque las barras metálicas (J) en los tornillos (I).

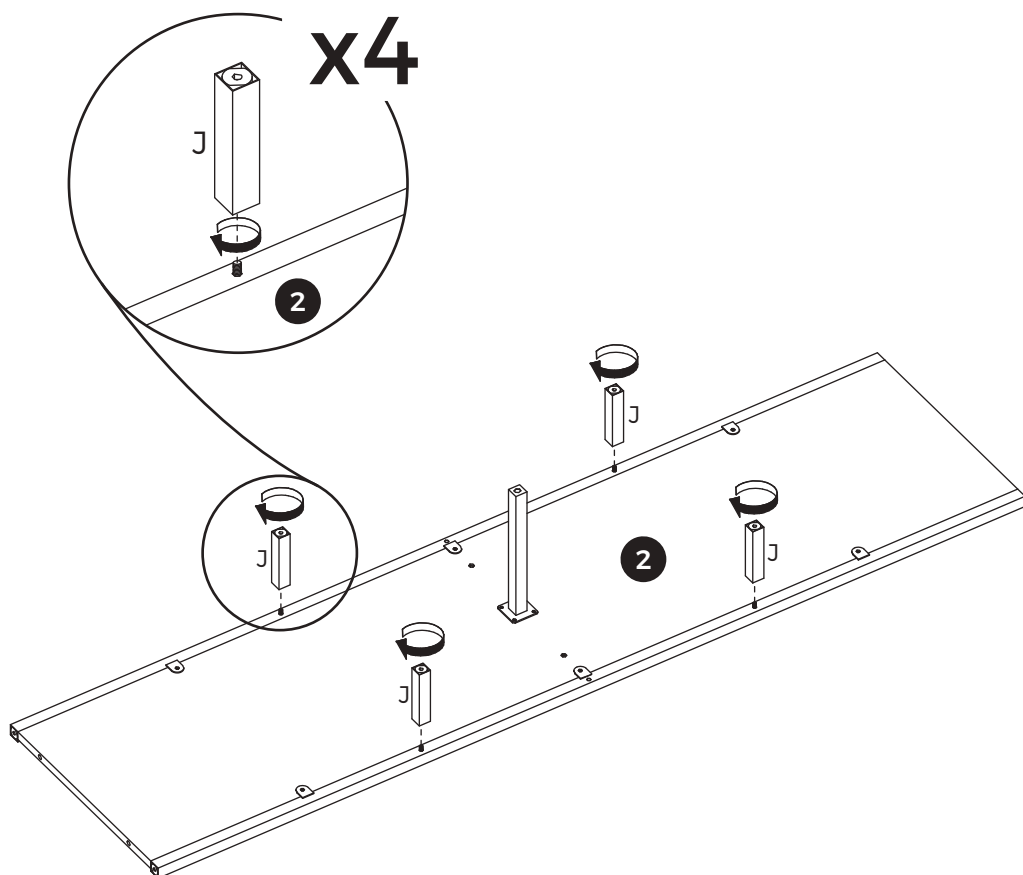

09



[EN] Connect plate 2 to plate 3 using wooden dowel (K).

[ES] Conecte el panel 2 con el panel 3 usando la espiga de madera (K).

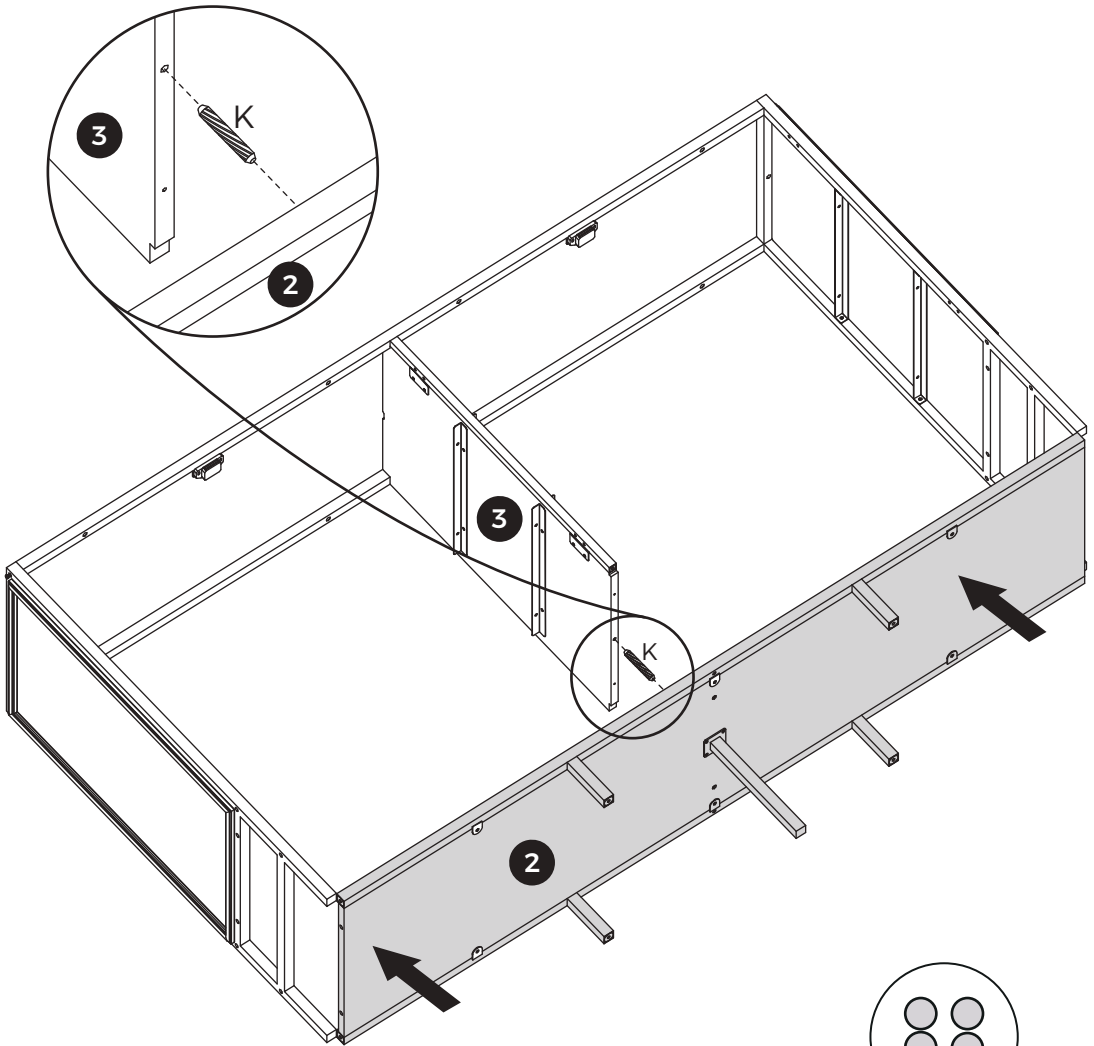

2 ADULTS

10



[EN] Secure metal bar 6 to plate 3 using screw (E).

[ES] Fije la barra metálica 6 al panel 3 usando el tornillo (E).

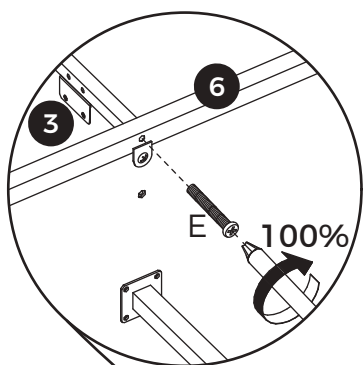

i [EN] Fully tighten this screw.
[ES] Apriete completamente este tornillo.

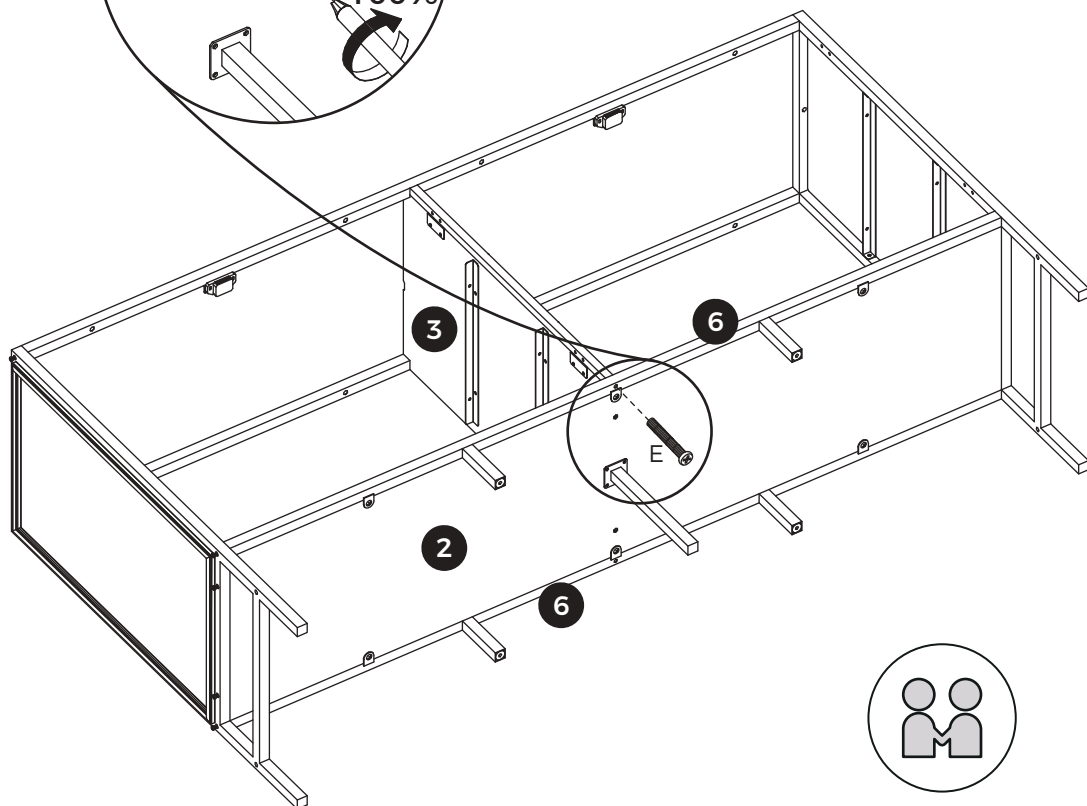

2 ADULTS

11



[EN] Connect metal frames 13 and 14 to plate 2 and the metal bar using screws (E).

[ES] Conecte los marcos metálicos 13 y 14 al panel 2 y a la barra metálica usando los tornillos (E).

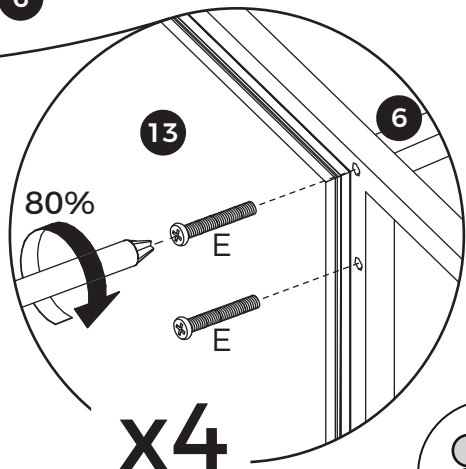
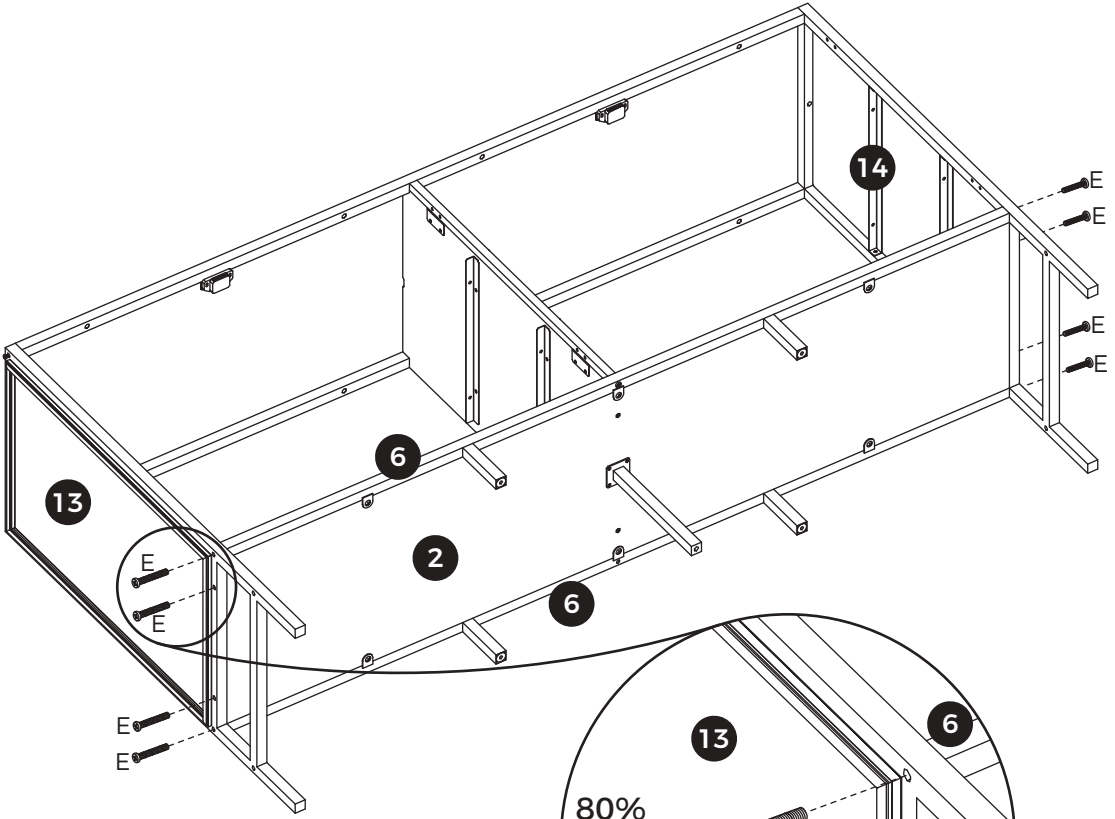

i [EN] Don't tighten the screws completely, about 80% will do.
[ES] No apriete los tornillos por completo; un 80% es suficiente.



2 ADULTS

12



[EN] Secure plate 2 to plate 3 using screws (L).

[ES] Fije el panel 2 al panel 3 usando los tornillos (L).

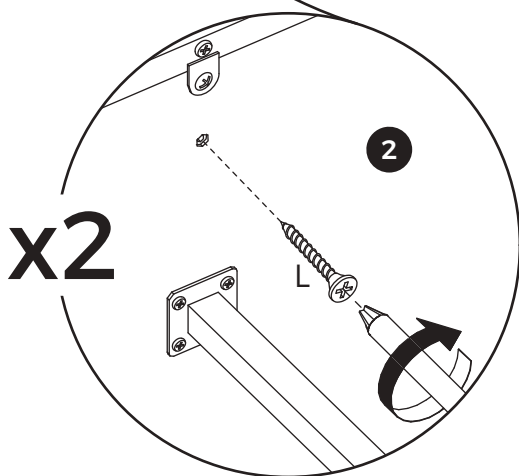
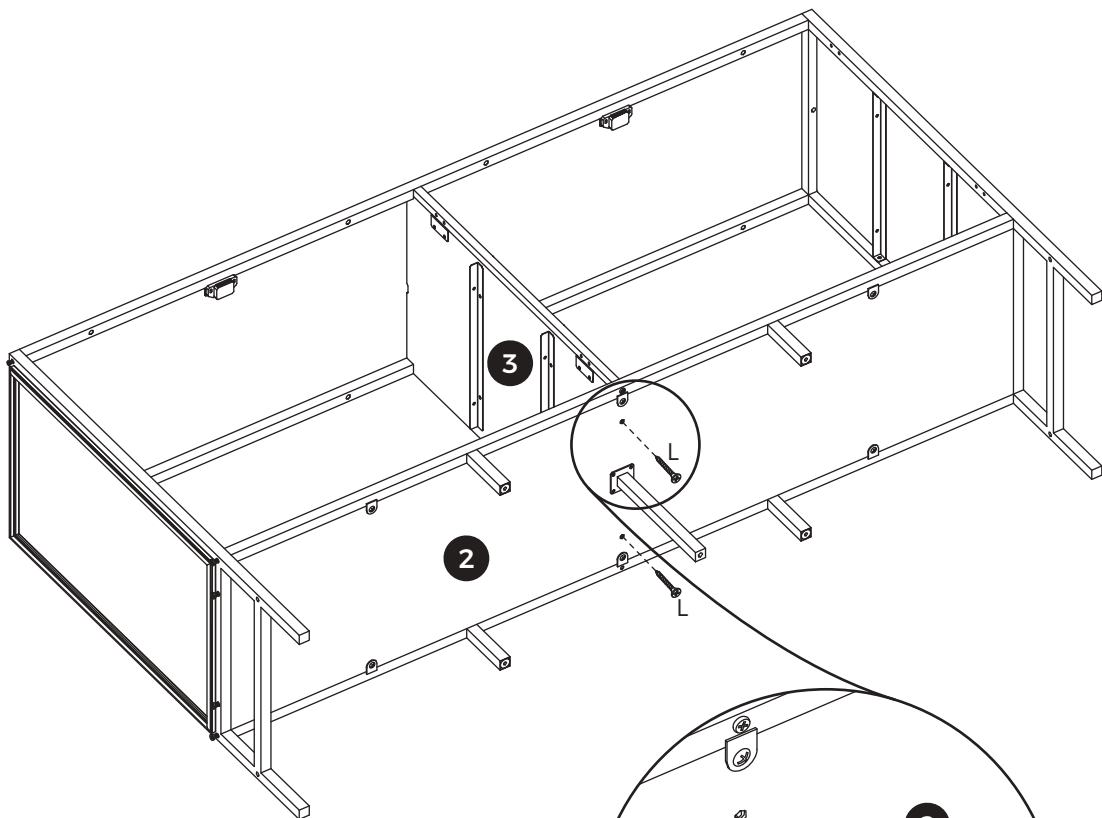

2 ADULTS

13



[EN] Secure metal bars 7 to the support bars using screws (E).

[ES] Fije las barras metálicas 7 a las barras de soporte usando los tornillos (E).

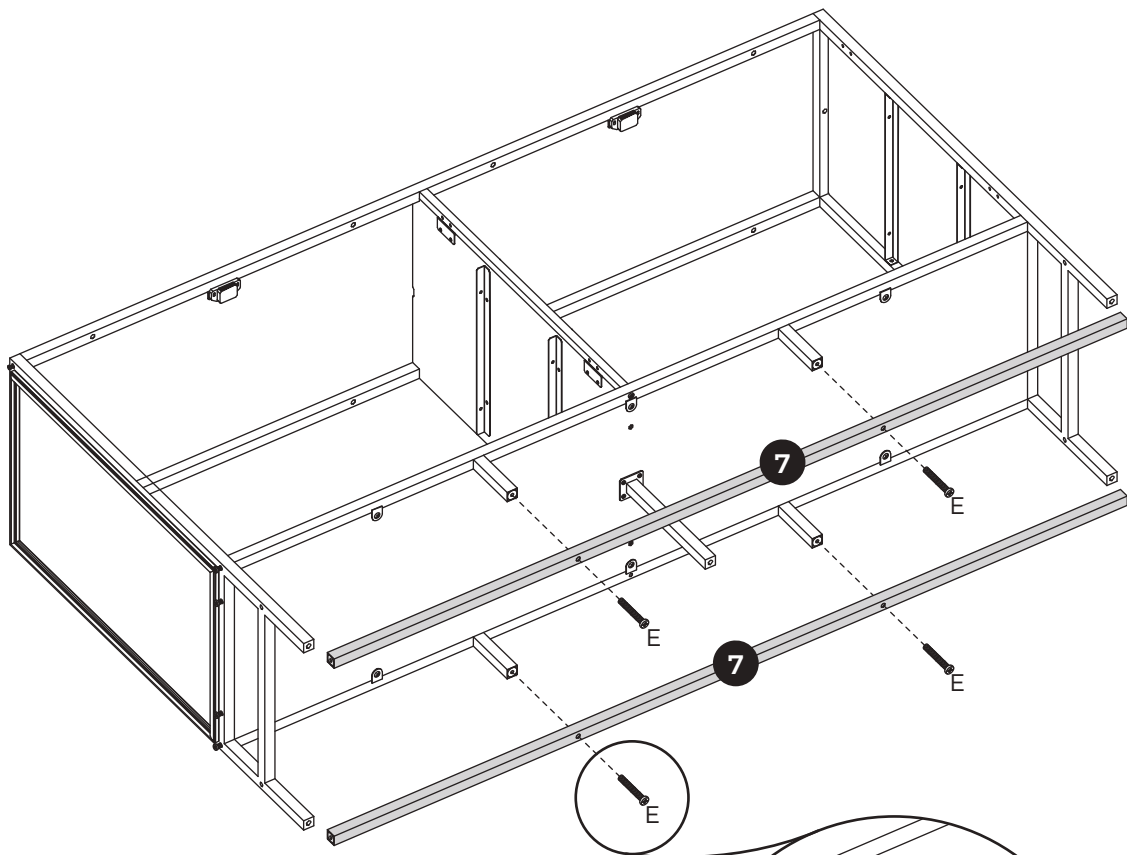

i [EN] Fully tighten these screws.
[ES] Apriete completamente estos tornillos.



2 ADULTS

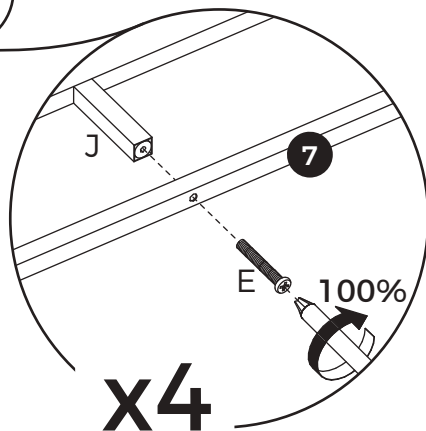

x4

14



[EN] Secure metal bars 7 to metal frames 13 and 14 using screws (E).

[ES] Fije las barras metálicas 7 a los marcos metálicos 13 y 14 usando los tornillos (E).

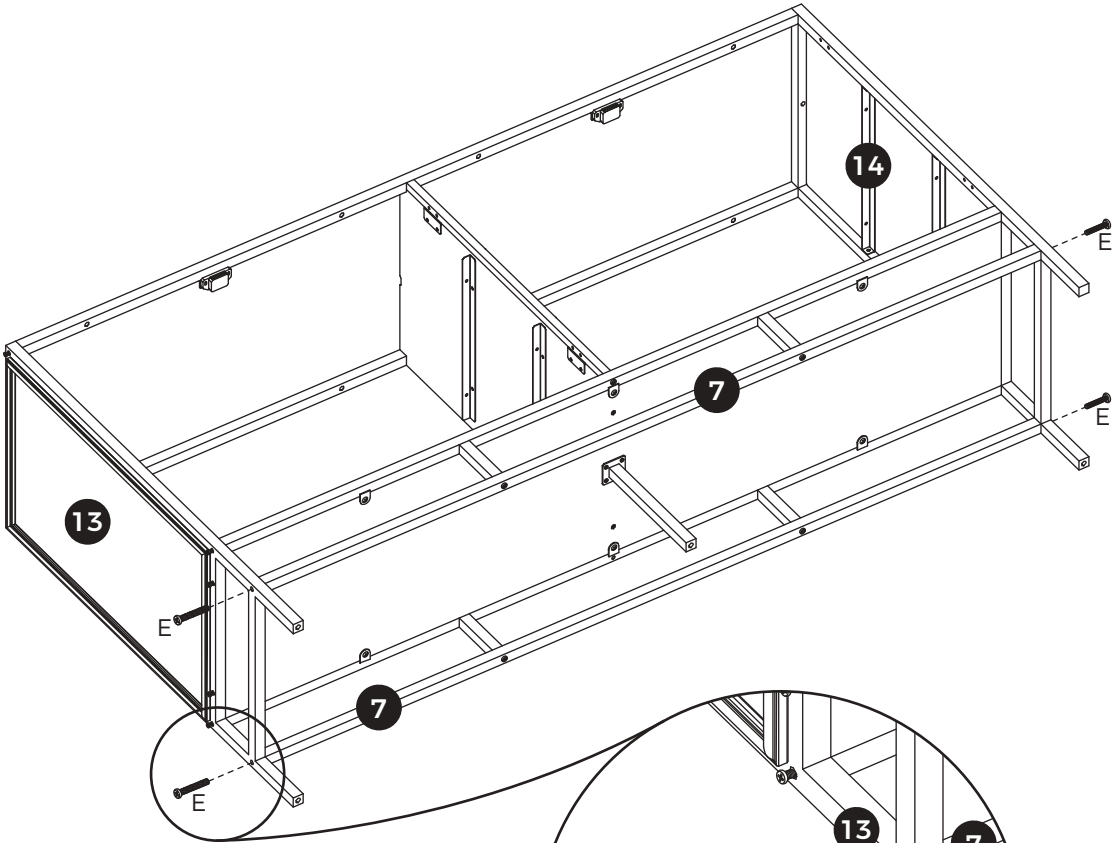

i [EN] Don't tighten the screws completely, about 80% will do.
[ES] No apriete los tornillos por completo; un 80% es suficiente.

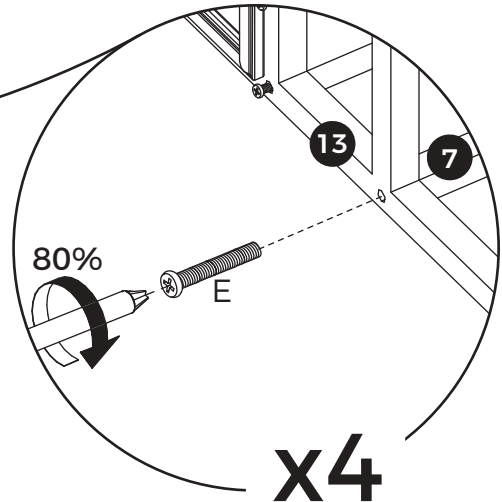

2 ADULTS

15



M x 5

[EN] Attach foot pads (M) to the metal frames and leg support; turn clockwise to tighten.

[ES] Coloque las almohadillas (M) en los marcos metálicos y el soporte de la pata; gírelas en sentido horario para apretarlas.

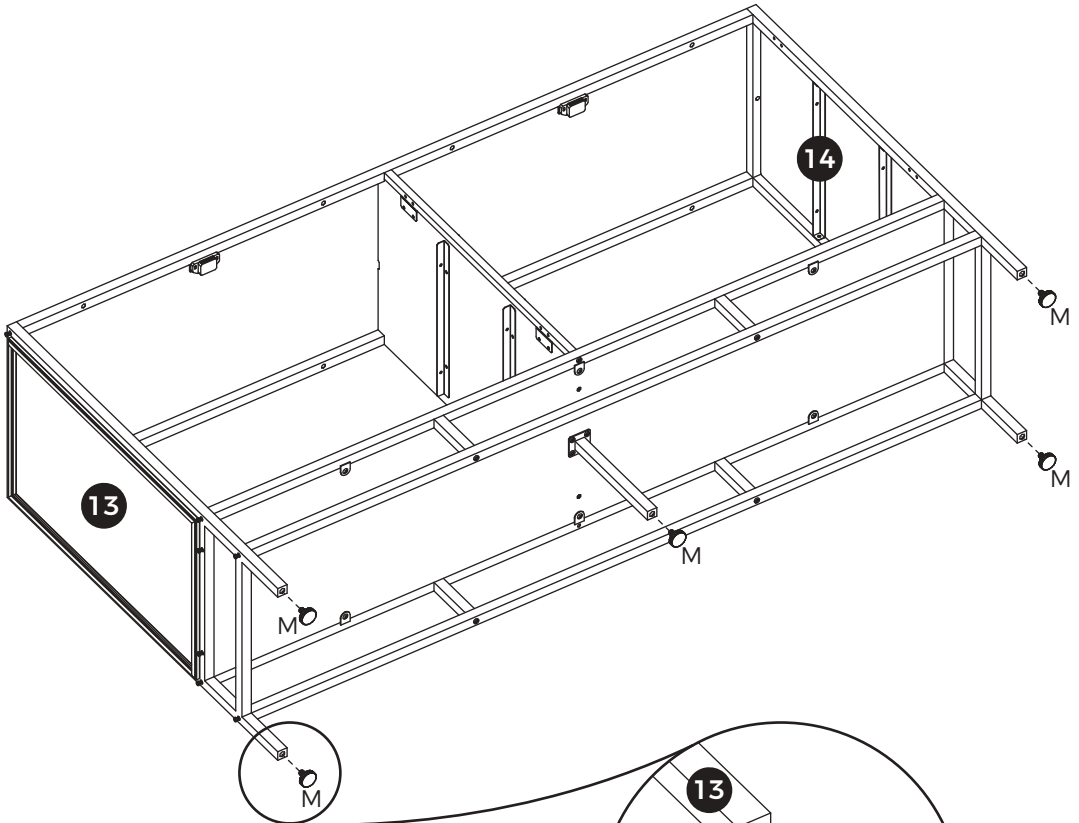

2 ADULTS

x5

16

[EN] Remove the plastic lamp cover.

[ES] Retire la cubierta plástica de la lámpara.

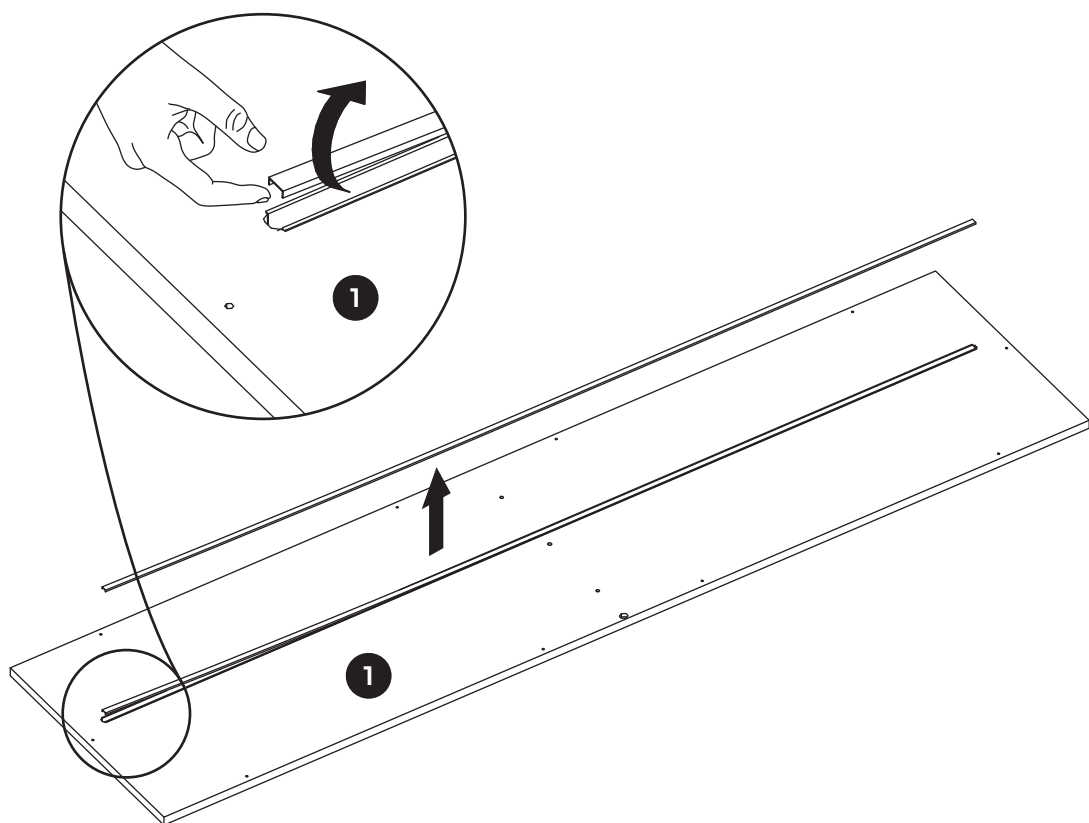

17



[EN] Peel off the backing and attach the light belt (N) to the cover.

[ES] Retire el papel protector y fije la tira de luz (N) a la cubierta.

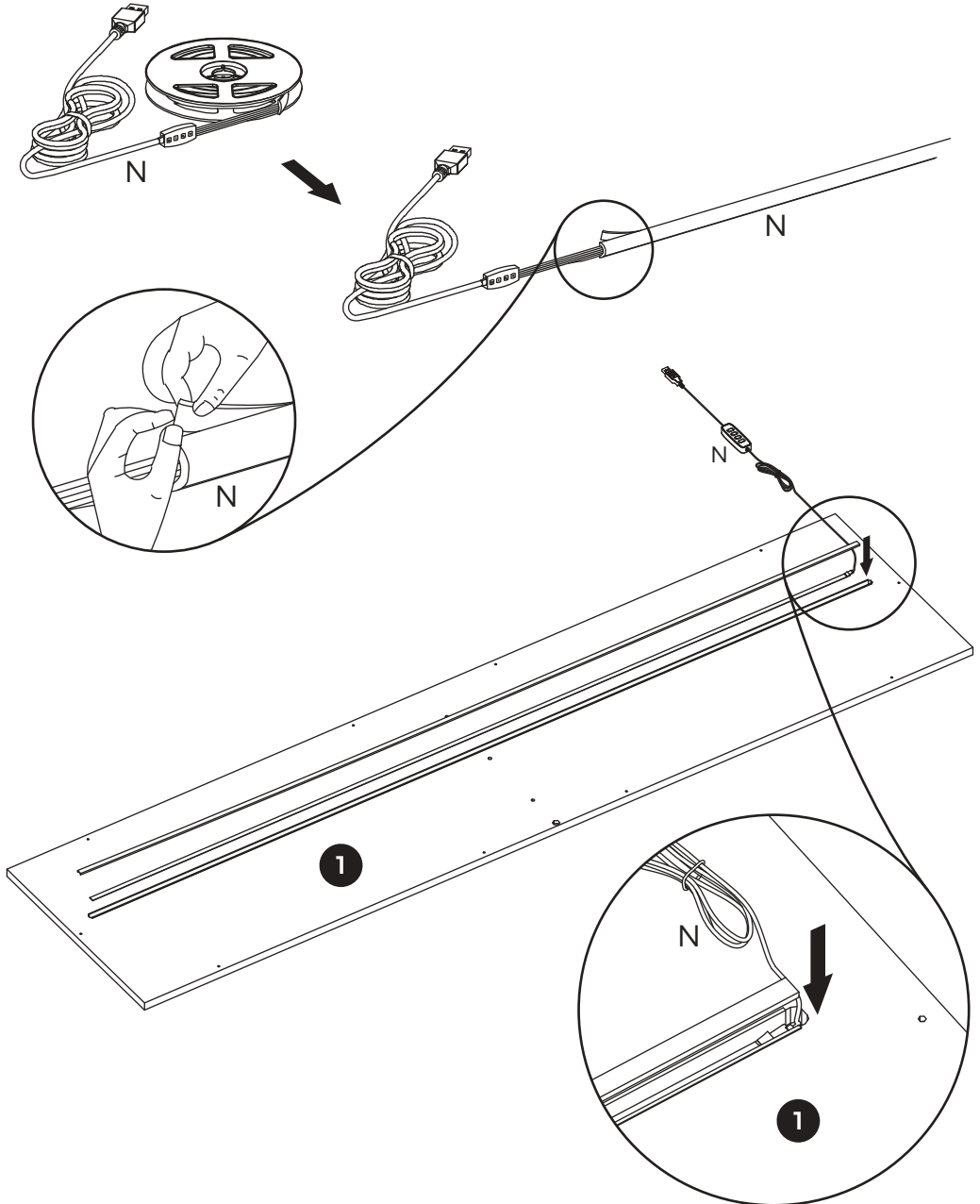

18



[EN] Screw eccentric rods (O) onto plate 1.

[ES] Enrosque las varillas excéntricas (O) en el panel 1.

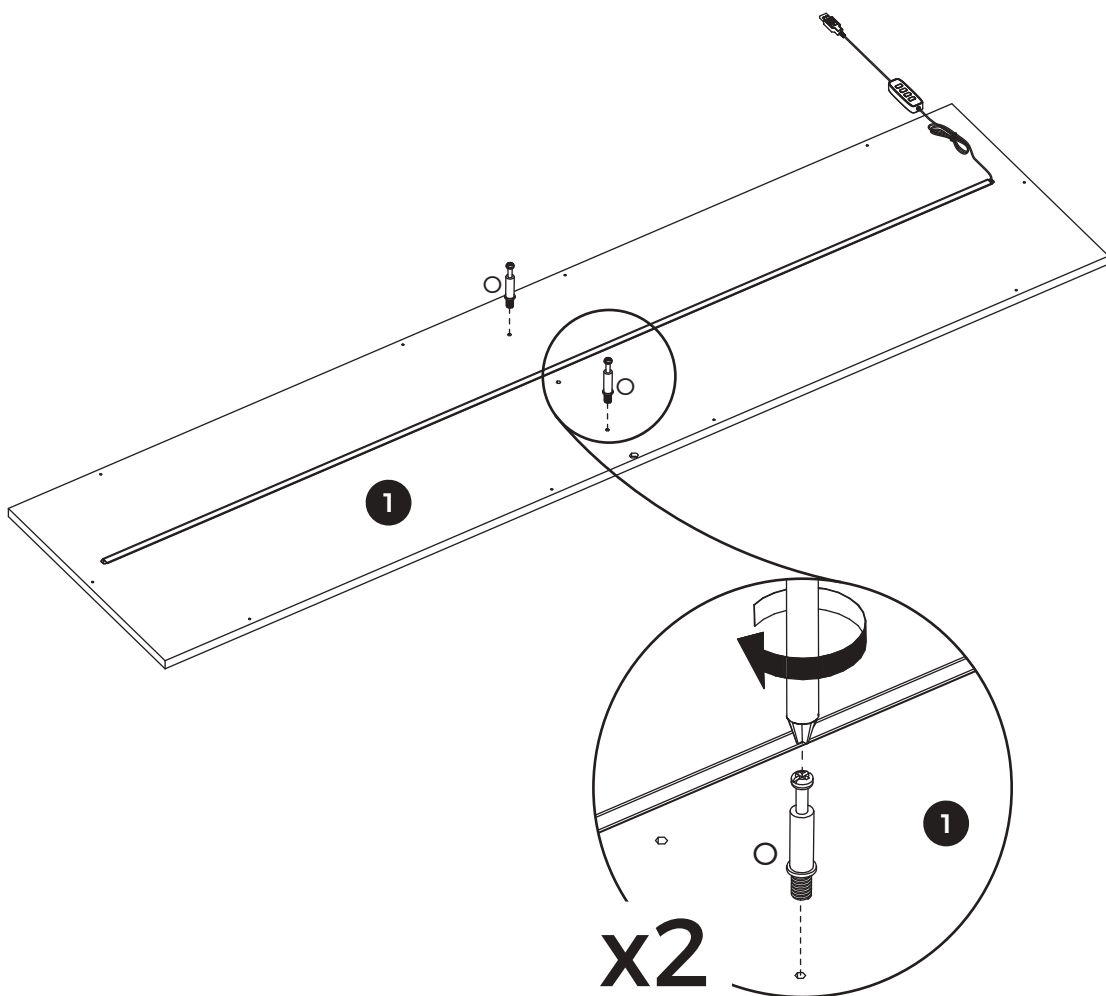

19

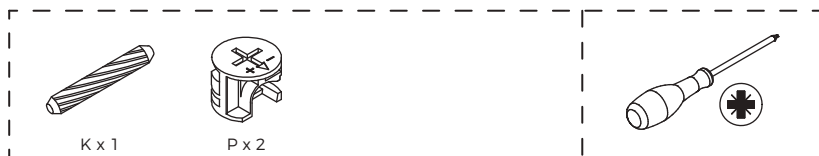

[EN] Connect plate 1 to plate 3 using wooden dowel (K); then tighten by turning the cam locks (P) clockwise.

[ES] Conecte el panel 1 con el panel 3 usando la espiga de madera (K); luego apriete girando las cerraduras excéntricas (P) en sentido horario.

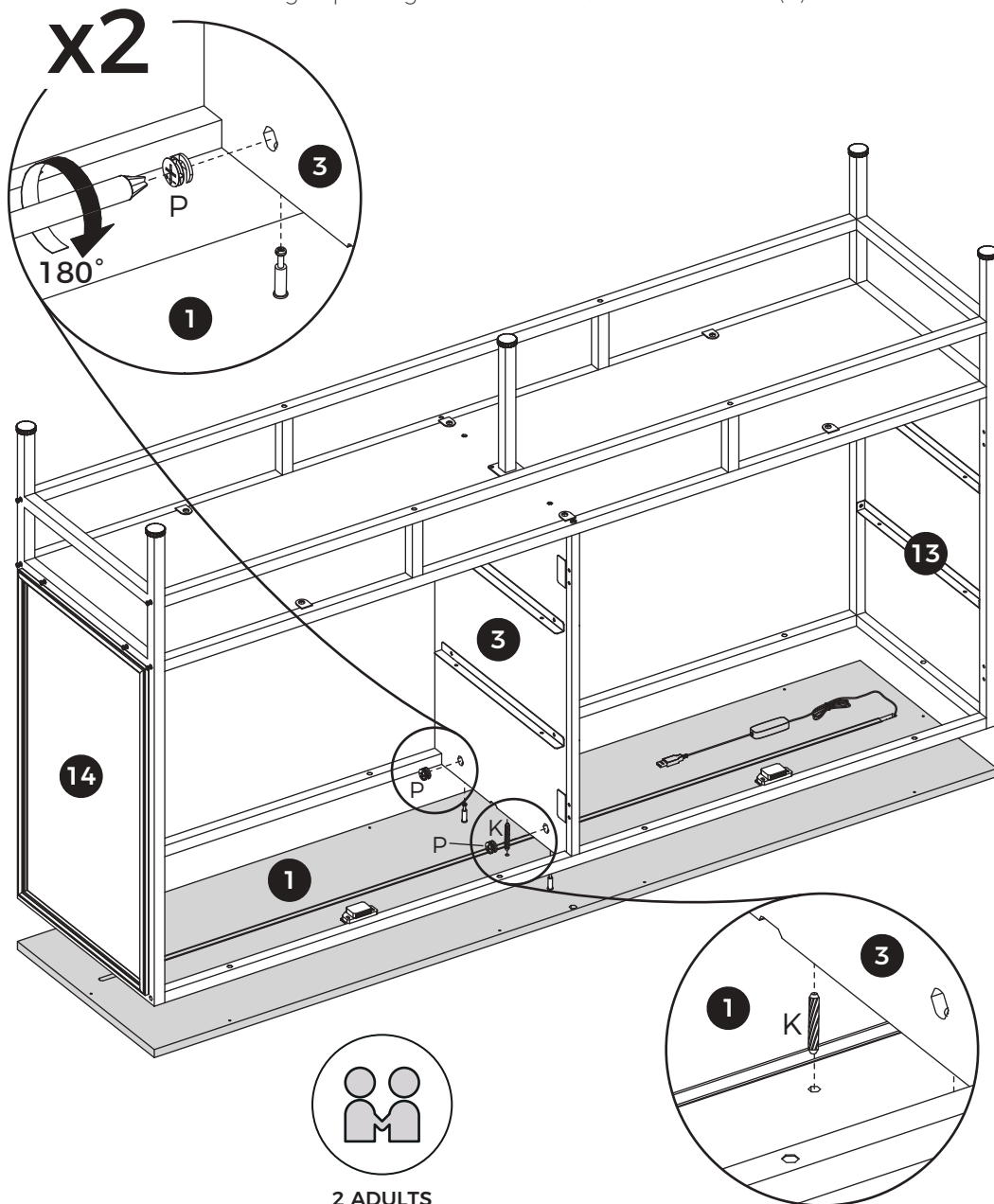

20



[EN] Secure plate 1 to the metal bars using screws (Q).

[ES] Fije el panel 1 a las barras metálicas usando los tornillos (Q).

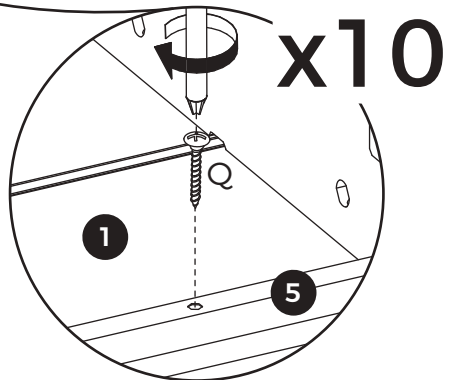
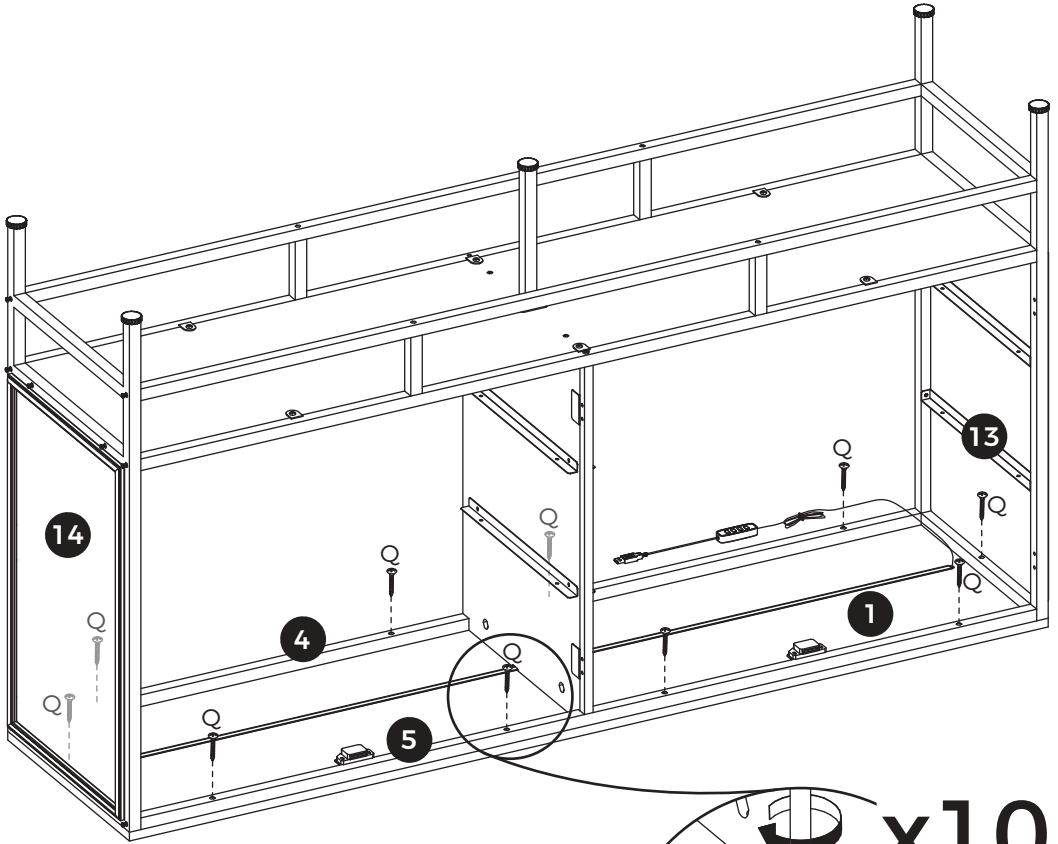

2 ADULTS

21



H x 16

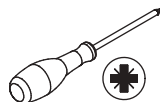

[EN] Secure backplates 11 and 12 to the unit using screws (H).

[ES] Fije las placas traseras 11 y 12 a la unidad usando los tornillos (H).



[EN] First, remove the switch from the light belt; then install the backplates.

[ES] Primero, retire el interruptor de la tira de luz; luego instale las placas traseras.

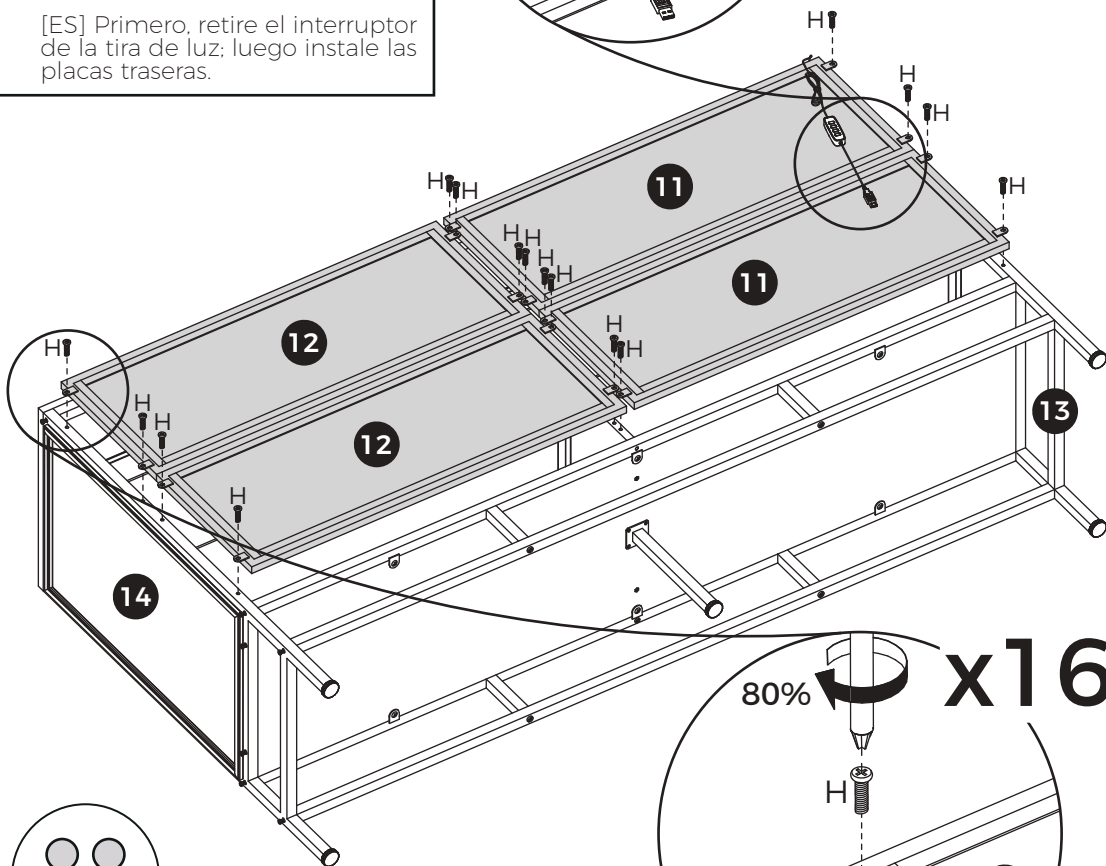
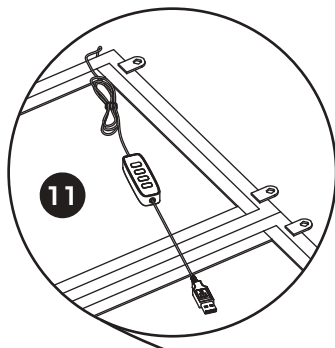

2 ADULTS



[EN] Don't tighten the screws completely, about 80% will do.

[ES] No apriete los tornillos por completo; un 80% es suficiente.

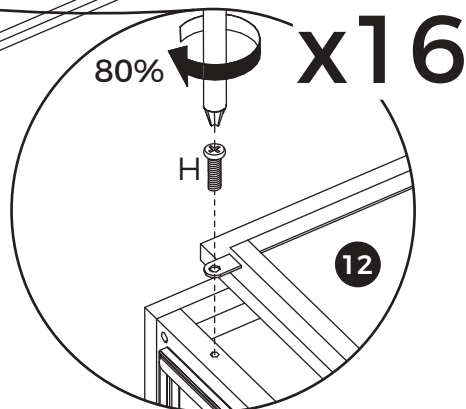

22



R x 16

[EN] Install suction cups (R) on the unit.

[ES] Instale las ventosas (R) en la unidad.

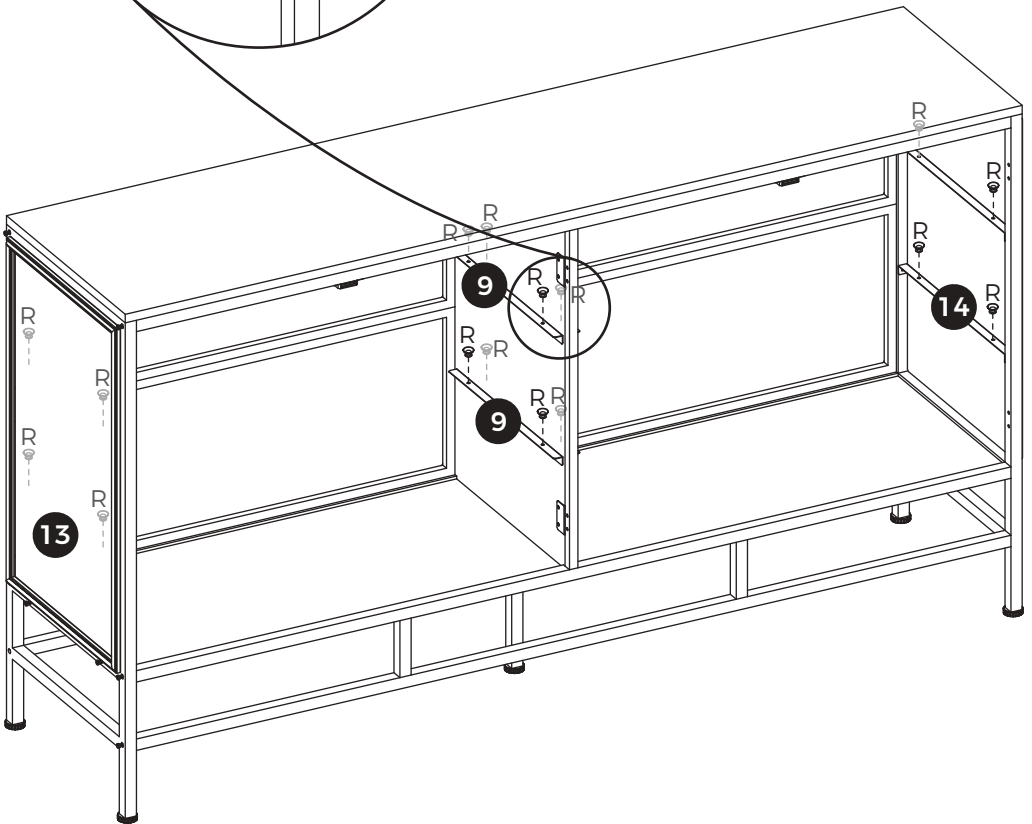
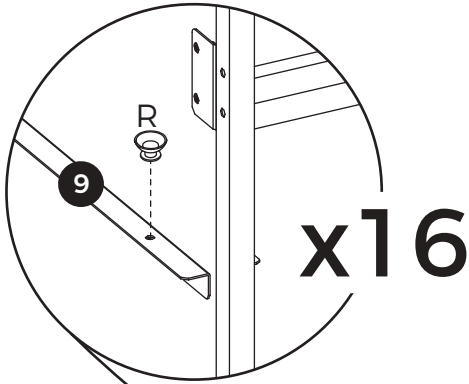

23

[EN] Place glass plates 8 on the suction cups.

[ES] Coloque las placas de vidrio 8 sobre las ventosas.

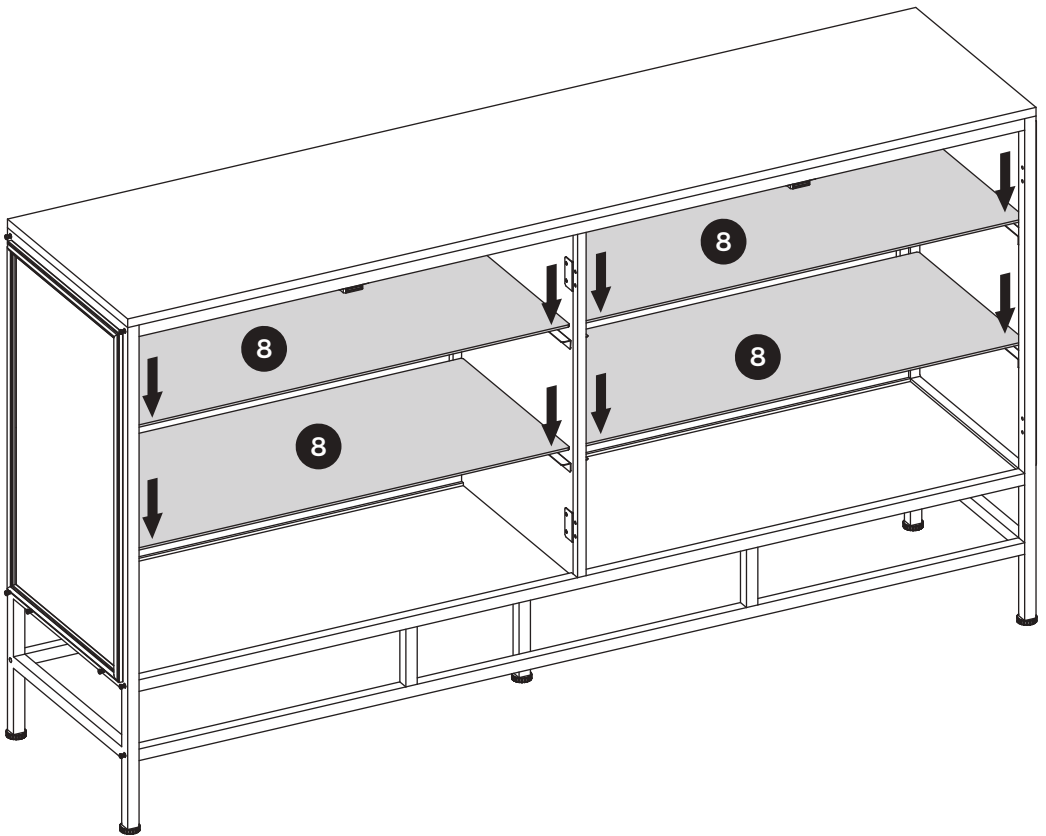

2 ADULTS

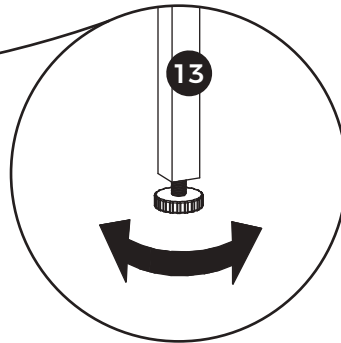
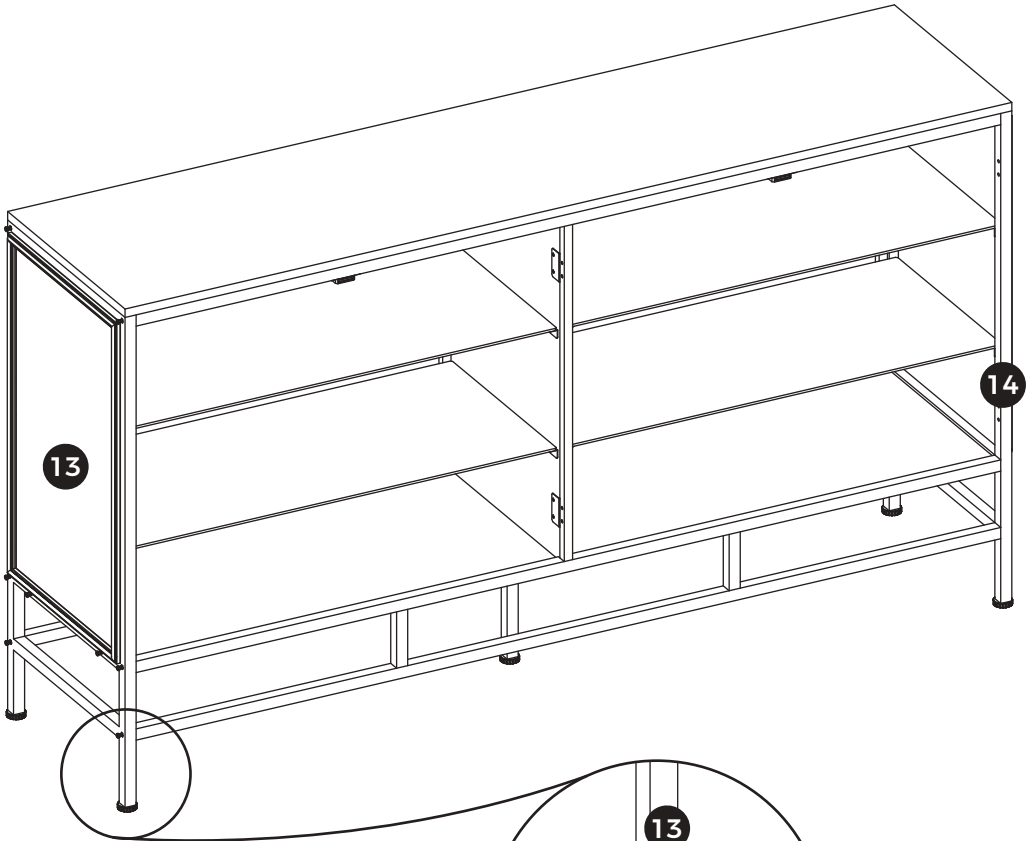

[EN] If the unit looks uneven after assembly, you can improve it by adjusting the foot pads as shown in the picture.

[ES] Si la unidad se ve desnivelada después del montaje, puede corregirla ajustando las patas niveladoras según se muestra en la imagen.



2 ADULTS

25

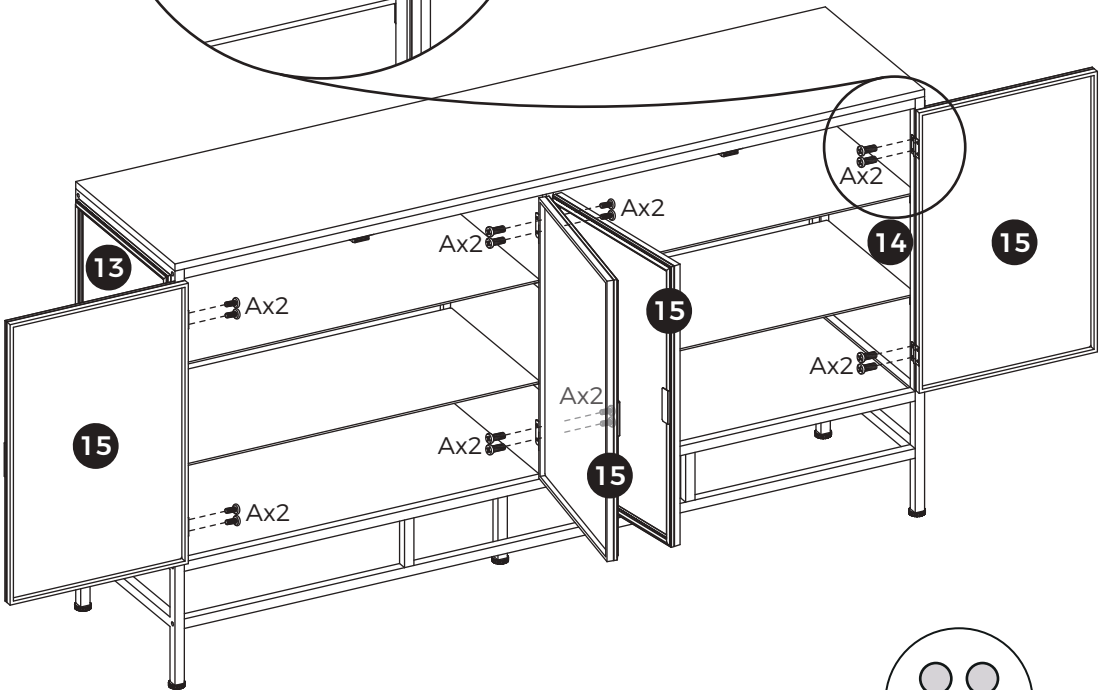
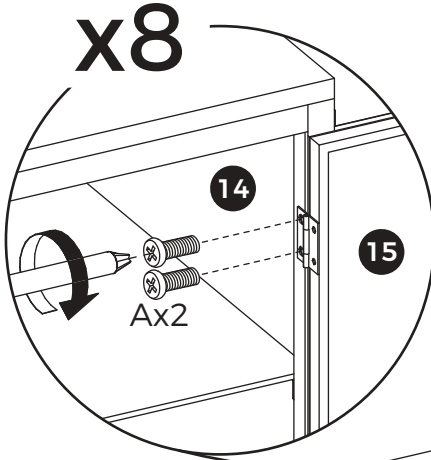

2 ADULTS

26

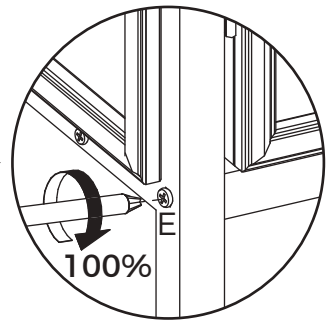
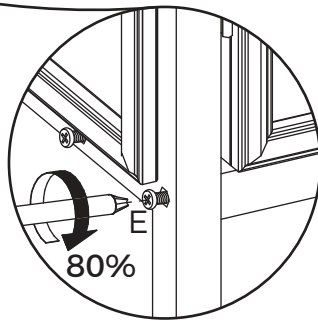
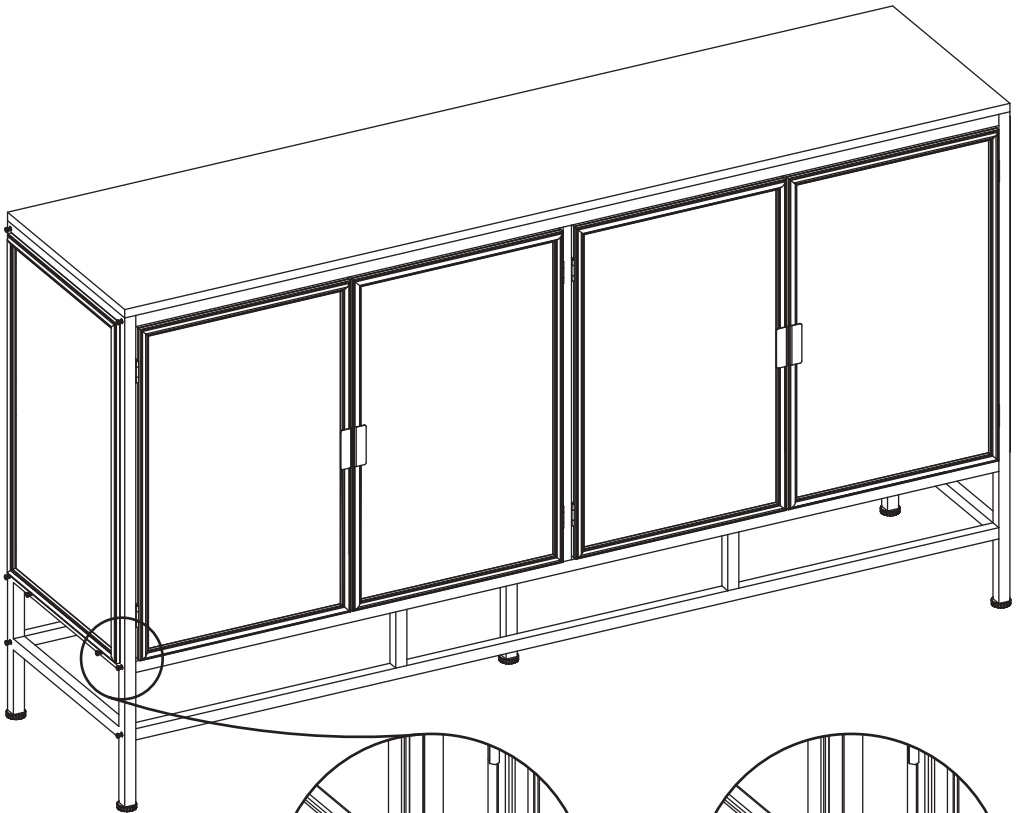

[EN] Fully tighten all screws (E) and (H).

[ES] Apriete completamente todos los tornillos (E) y (H).



2 ADULTS

27



[EN] Fix sheets (T) to the top of the unit using screws (F).

[ES] Fije las láminas (T) a la parte superior de la unidad usando los tornillos (F).

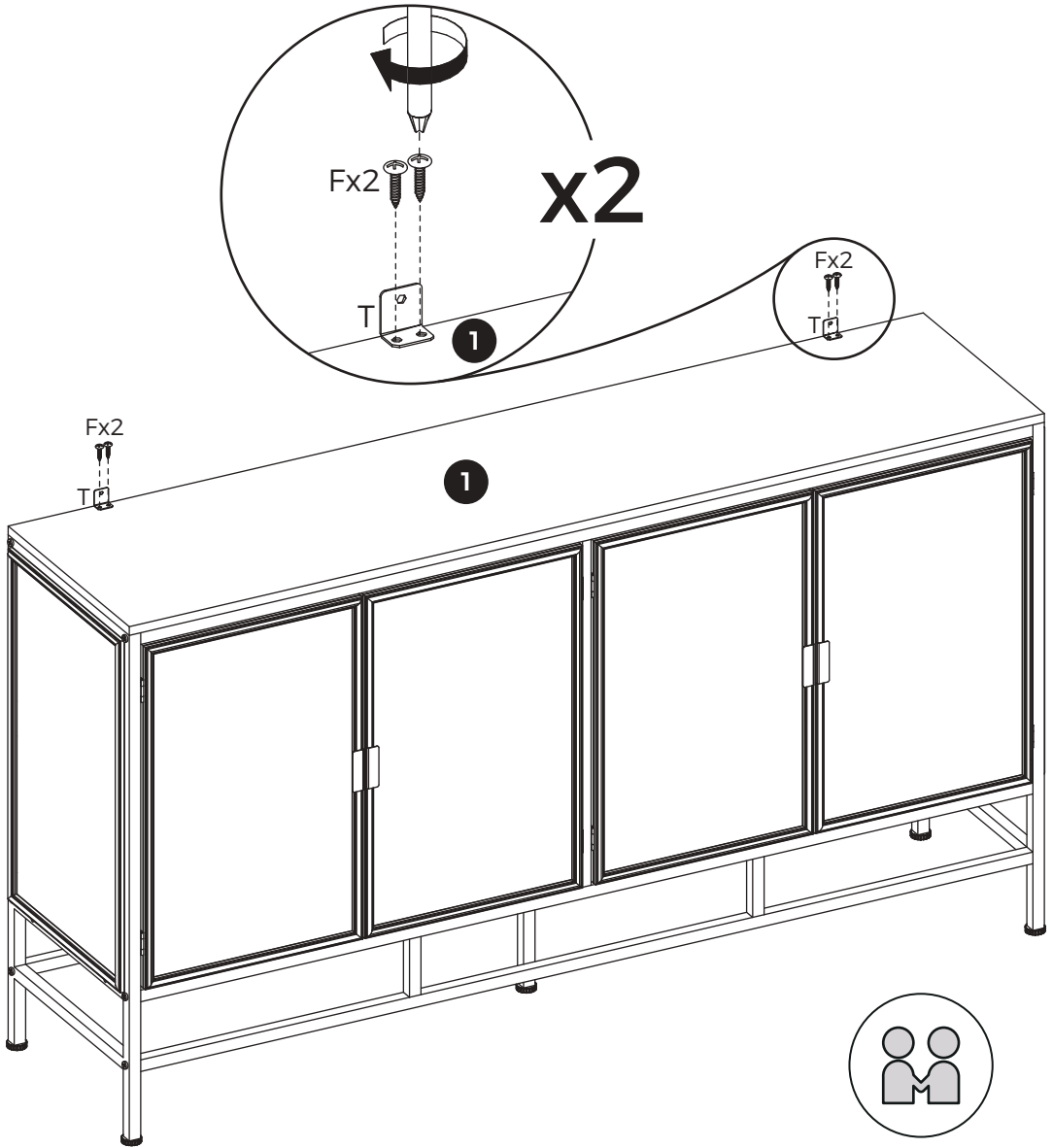

28



[EN] Install anti-tipping device as shown.

[ES] Instale el dispositivo anti-vuelco según se muestra.

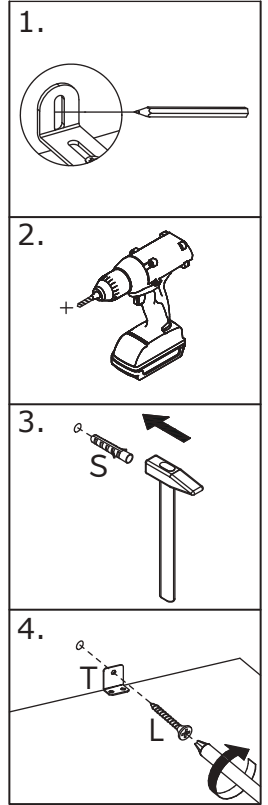
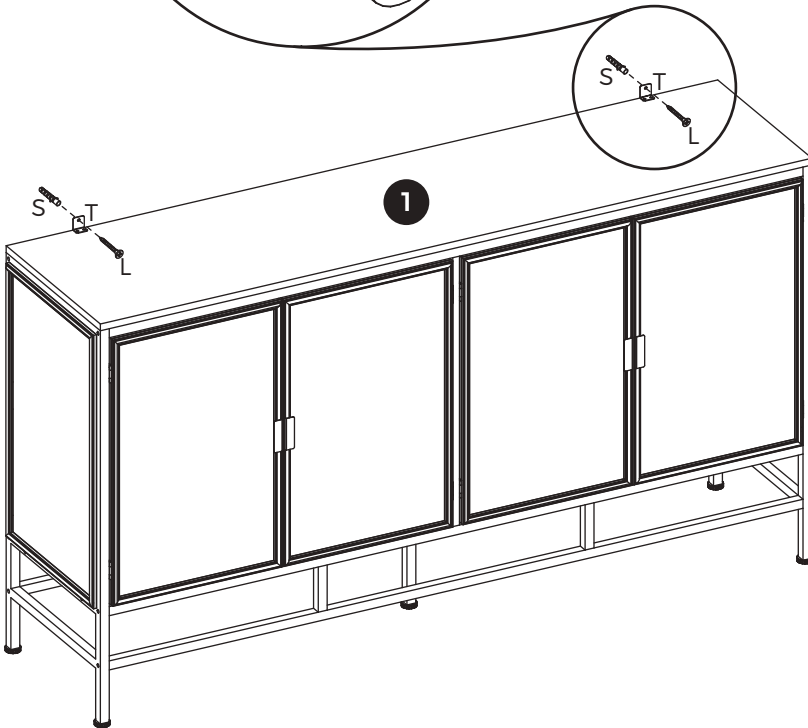
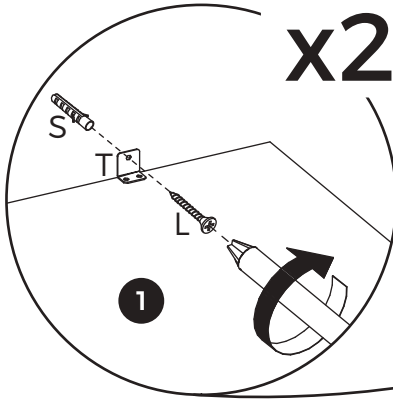

2 ADULTS

Should you have any problems assembling your product, contact us at **customerservice@homsee.com**. We're always happy to help! We have carefully selected the materials used in this product, and ask you to treat it responsibly too. Please recycle all packaging according to your local disposal rules.

Si tienes algún problema al ensamblar tu producto, contáctanos a **customerservice@homsee.com**. Siempre estaremos encantados de ayudarte. Hemos seleccionado cuidadosamente los materiales utilizados en este producto y te pedimos que también lo trates de manera responsable. Por favor, recicla todo el embalaje de acuerdo con las normas locales de eliminación de residuos.

