



# ASSEMBLY INSTRUCTIONS





---

One of the unique features of Homsee furniture is its versatility. Designed with the idea of customization in mind, our products can be easily linked together to create seamless, personalized setups that fit your specific needs.

For instance, if you purchase a couple of our shelves, you can effortlessly combine them to form a larger, unified structure. This modular approach allows you to expand, rearrange, and adapt your furniture as your space and style evolve. Whether you're looking to create a vast shelving system, or a continuous storage solution, the possibilities are endless.

At Homsee, we empower you to create a space that is truly yours—one that grows with you, all while maintaining a sleek, cohesive look.



---

Una de las características distintivas del mobiliario Homsee es su versatilidad. Diseñados pensando en la personalización, nuestros productos pueden conectarse fácilmente entre sí para crear configuraciones continuas y personalizadas que se ajusten a tus necesidades específicas.

Por ejemplo, si compras un par de nuestras estanterías, puedes combinarlas sin esfuerzo para formar una estructura más grande y unificada. Este enfoque modular te permite ampliar, reorganizar y adaptar tus muebles a medida que evolucionan tu espacio y tu estilo. Ya sea que busques crear un amplio sistema de estanterías o una solución de almacenamiento continua, las posibilidades son infinitas.

En Homsee, te ayudamos a crear un espacio verdaderamente tuyo—uno que crece contigo, manteniendo a la vez un aspecto elegante y coherente.

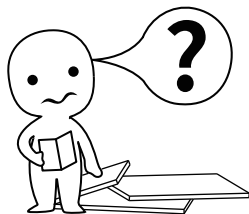

## IMPORTANT INFORMATION!

Please read the entire manual before starting to assembling or using this product. Follow the manual thoroughly and keep it for further reference.

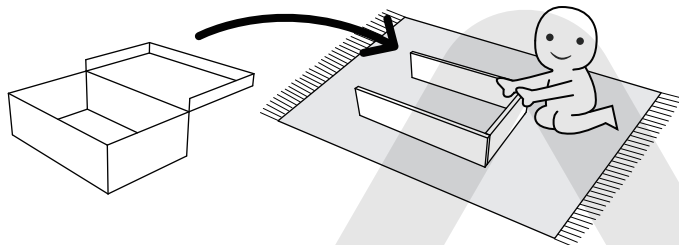

## AVOID SCRATCHES!

In order to avoid scratching the furniture should be assembled on a soft layer—could be a rug.

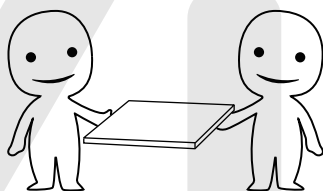

## IMPROVE ASSEMBLY EFFICIENCY !

Try to find a partner to install with you, which can speed up the installation efficiency and shorten the time.

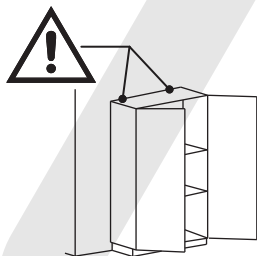

## ANTI-TOPPLE WARNING !

Overturned furniture can cause serious or fatal crush injuries. To prevent tipping, be sure to use a wall-anchoring attachment. If one is not included with this product, please purchase a suitable attachment that fits your wall. If unsure, seek professional advice. Please read and follow all instructions carefully.

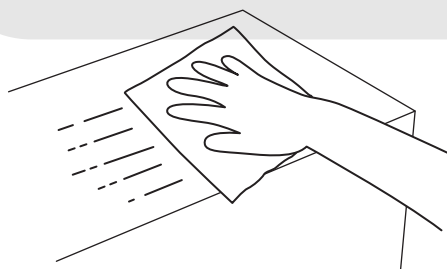

## MAINTENANCE AND CLEANING !

For regular maintenance and cleaning, use a rag dipped in neutral detergent to wipe the frame thoroughly, and then dry it with a clean rag. For glass surfaces, wipe with a rag dampened with water or glass cleaner, and then dry with a clean, dry cloth.



## ¡INFORMACIÓN IMPORTANTE!

Por favor, lee todo el manual antes de comenzar a ensamblar o usar este producto. Sigue las instrucciones detenidamente y consérvalo para futuras consultas.

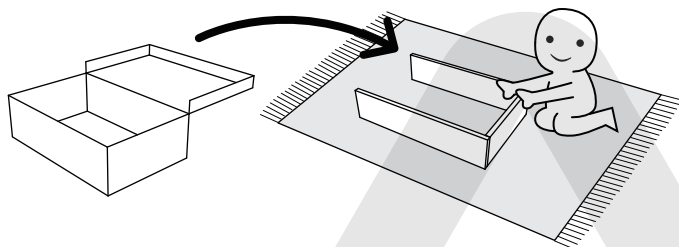

## ¡EVITA LOS RAYONES!

Para evitar que el mueble se raye, debe ensamblarse sobre una superficie suave, como una alfombra.

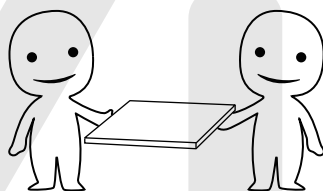

## ¡MEJORA LA EFICIENCIA!

Intenta encontrar a alguien que te ayude con la instalación; trabajar en pareja puede aumentar la eficiencia y reducir el tiempo de montaje.

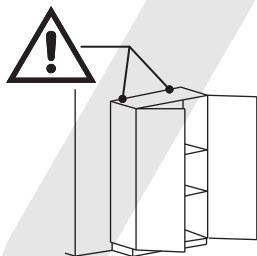

## ¡ADVERTENCIA ANTIVUELCO!

El mobiliario volcado puede causar lesiones graves o incluso mortales por aplastamiento. Para evitar que se vuelque, asegúrate de utilizar el sistema de anclaje a la pared. Si este producto no lo incluye, adquiere un anclaje compatible con tu pared. Si no estás seguro de cuál usar, busca asesoramiento profesional. Lee y sigue cuidadosamente cada paso de las instrucciones.

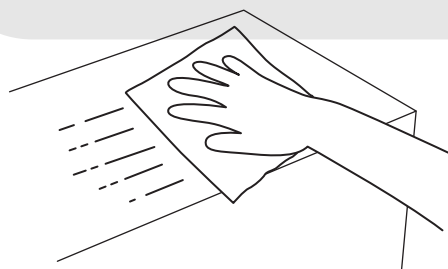

## ¡MANTENIMIENTO Y LIMPIEZA!

Para el mantenimiento y la limpieza regulares del producto, limpia el marco con un paño humedecido en un detergente neutro y luego sécalo con un paño limpio. Para los materiales de vidrio, límpialos con un paño humedecido en limpiador de vidrios con agua y luego sécalos con un paño seco.



The following are common installation steps. Correct operation is required to avoid product damage.

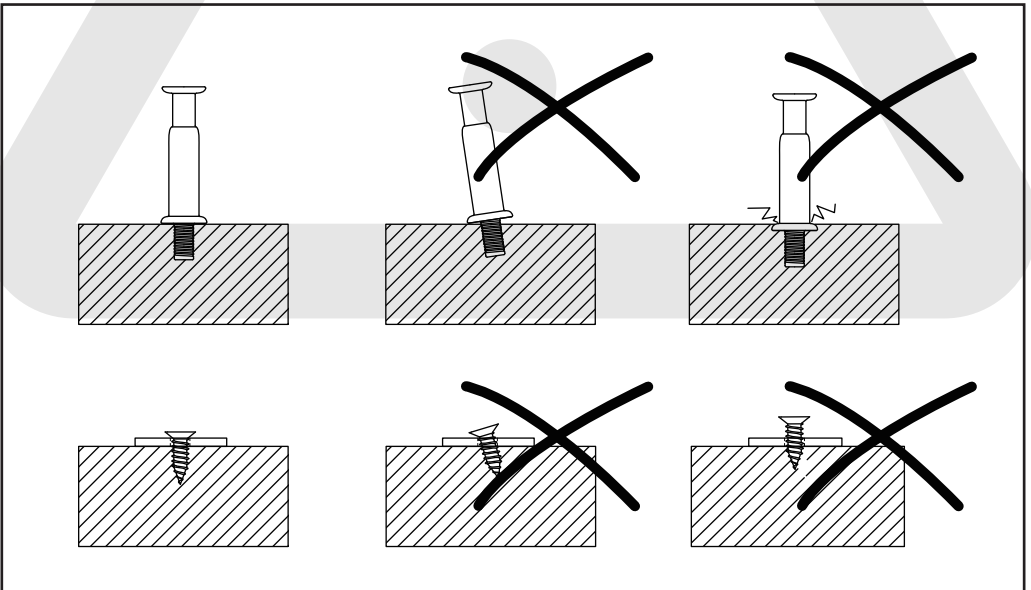
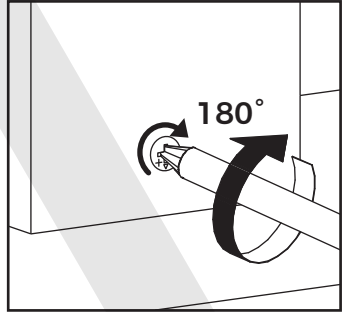
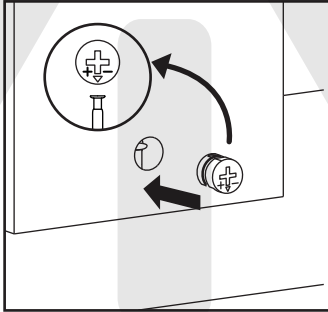
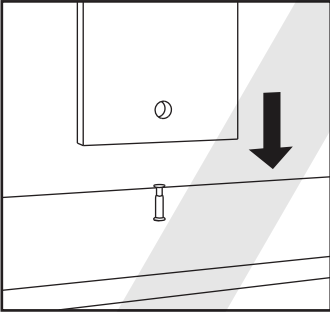
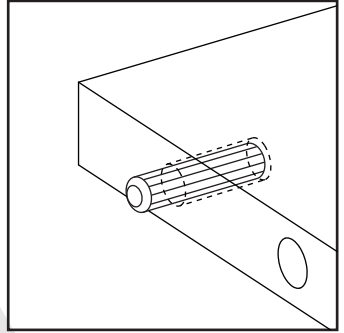
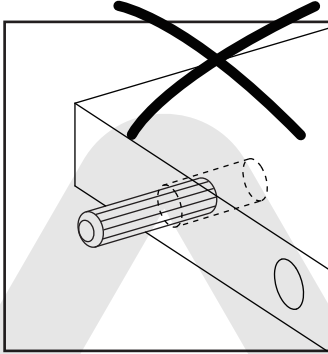
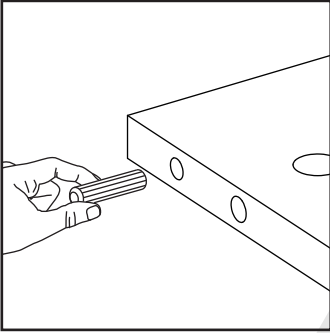



Los siguientes pasos de instalación son bastante comunes y requieren una operación correcta durante el proceso de montaje. El uso incorrecto puede dañar el mueble.

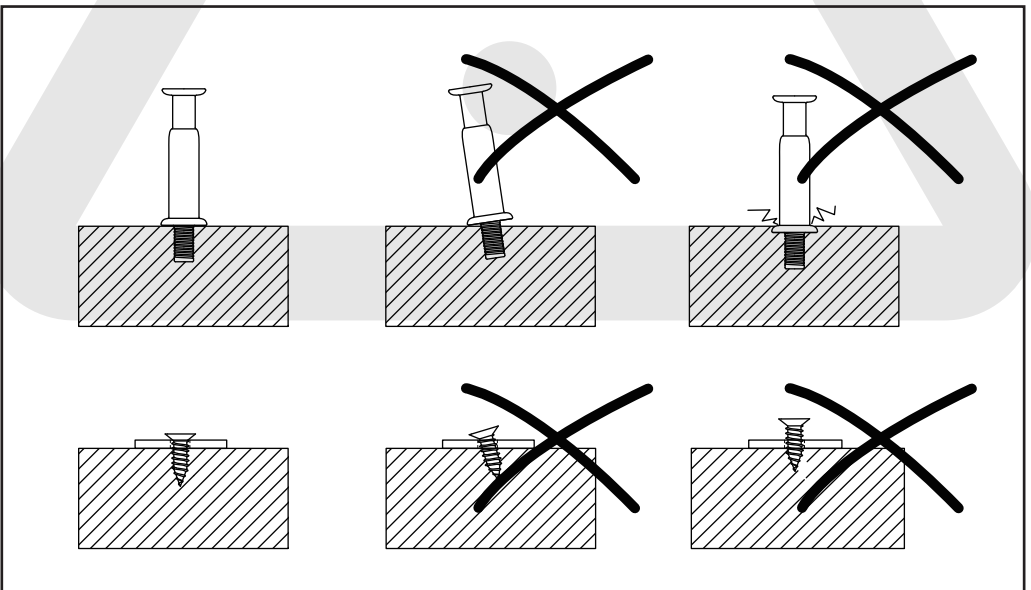
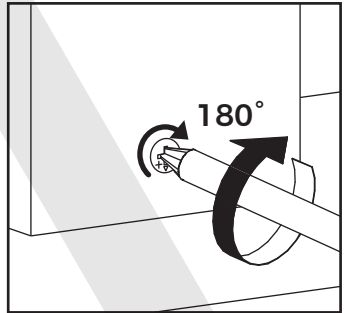
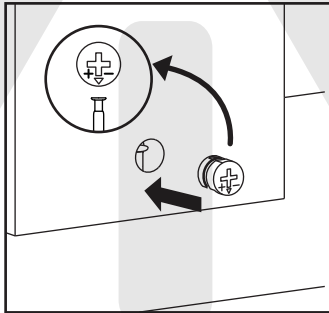
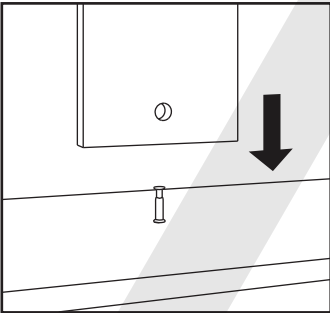
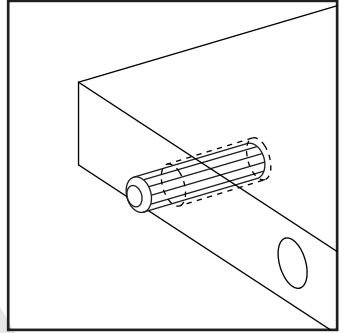
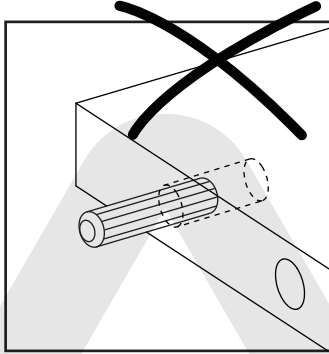
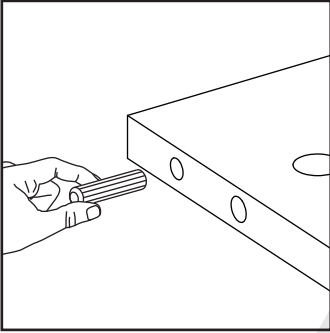



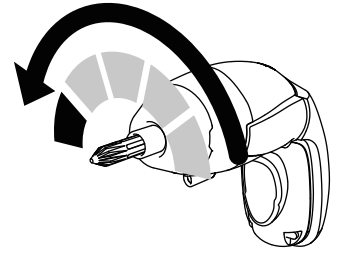
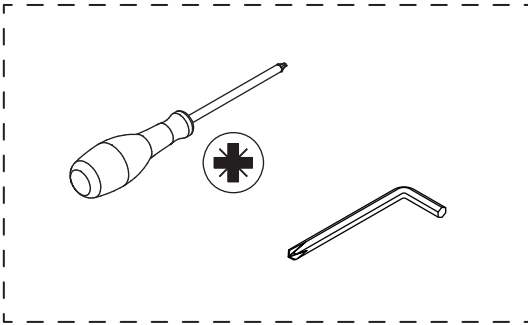





**Please prepare the following tools**

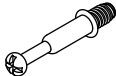

If you choose to use power tools, set it to the lower power setting. Be careful! Power tools can cause cracking or damage to the furniture, and damage the hardware.

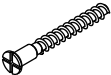

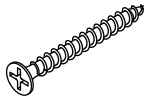
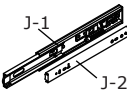
Some accessories have similar shape, please distinguish them according to their numbers and sizes during installation.

<p>A x 71</p>  <p>Ø15 x 10 mm</p>	<p>B x 71</p>  <p>Ø6 x 35 mm</p>	<p>C x 28</p>  <p>Ø6 x 30 mm</p>	<p>D x 4</p>  <p>Ø6 x 20 mm</p>	<p>E x 71</p> 
<p>F x 38</p>  <p>Ø5 x 40 mm</p>	<p>G x 32</p>  <p>Ø3.5 x 12 mm</p>	<p>H x 4</p>  <p>Ø4 x 25 mm</p>	<p>J x 8</p>  <p>250 mm</p>	<p>K x 1</p> 

**Por favor, prepara las siguientes herramientas**

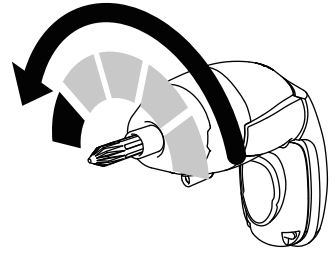
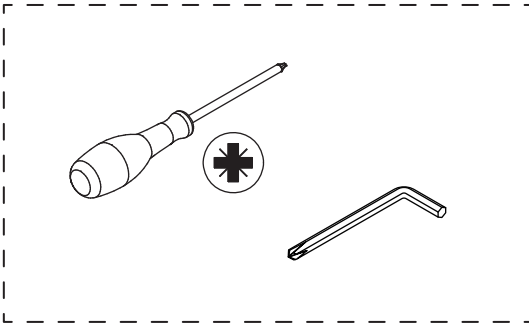

Si decides utilizar herramientas eléctricas, ajústalas a una velocidad baja. ¡Ten cuidado! Las herramientas eléctricas pueden causar grietas o daños en el mueble, y también pueden dañar los herrajes.



Algunos accesorios tienen la misma forma: por favor, distínguelos según sus números y tamaños durante la instalación.

<p>A x 71</p> <p>Ø15 x 10 mm</p>	<p>B x 71</p> <p>Ø6 x 35 mm</p>	<p>C x 28</p> <p>Ø6 x 30 mm</p>	<p>D x 4</p> <p>Ø6 x 20 mm</p>	<p>E x 71</p>
<p>F x 38</p> <p>Ø5 x 40 mm</p>	<p>G x 32</p> <p>Ø3.5 x 12 mm</p>	<p>H x 4</p> <p>Ø4 x 25 mm</p>	<p>J x 8</p> <p>250 mm</p>	<p>K x 1</p>

# Parts List

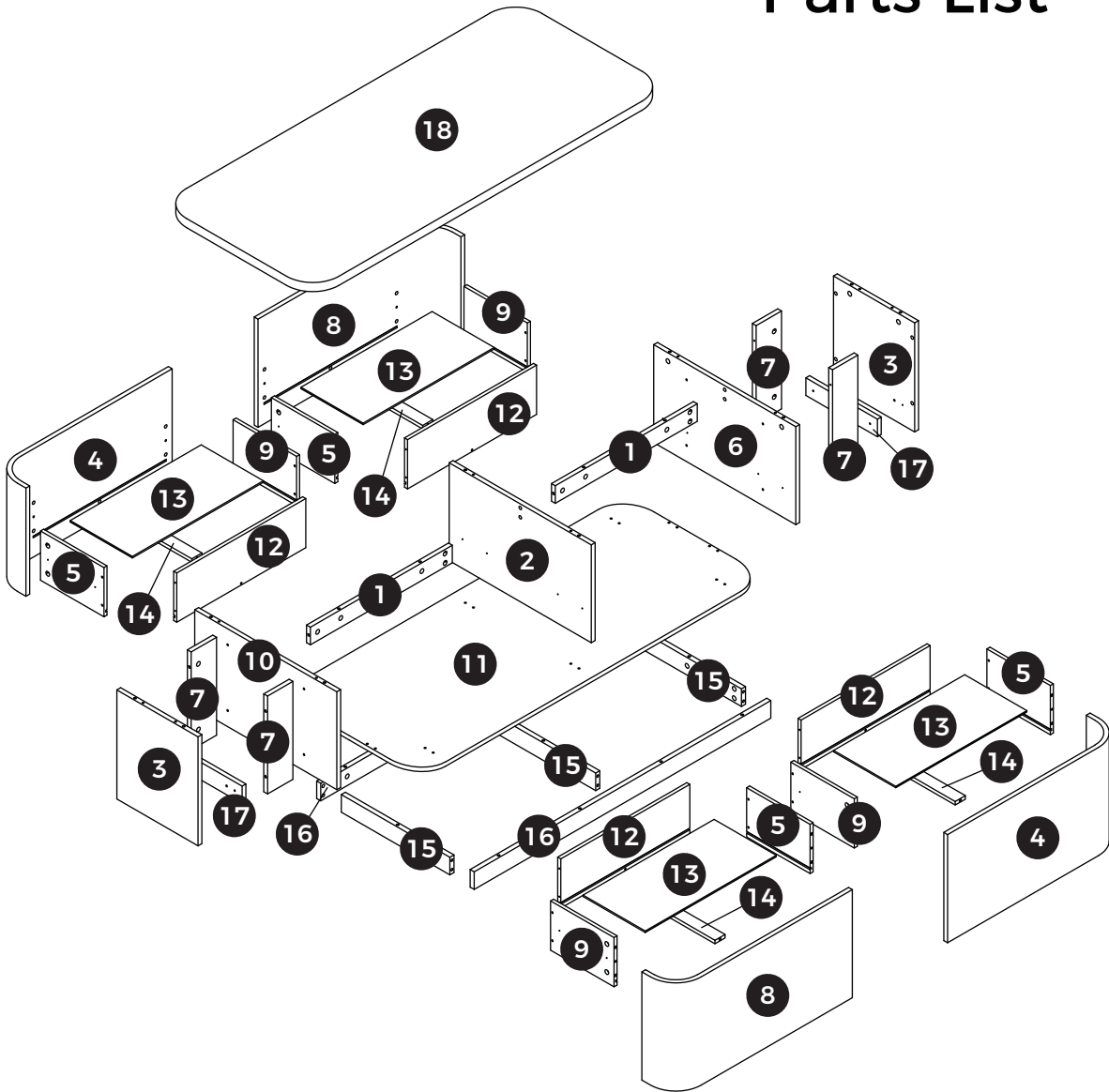

<b>WARNING</b>	
	<p><b>Children have died from furniture tipover. To reduce the risk of furniture tipover:</b></p> <ul style="list-style-type: none"> <li>• ALWAYS install Anti-tip device provided</li> <li>• NEVER put a TV on this product.</li> <li>• NEVER allow children to stand, climb or hang on drawers, doors, or shelves.</li> <li>• NEVER open more than one drawer at a time.</li> <li>• Place heaviest items in the lowest drawers.</li> </ul>
	<p style="text-align: center;"><b>This is a permanent label. Do not remove!</b></p>



**90 MINUTES**



**2 ADULTS**



**INTERMEDIATE**

The parts listed above are required for proper assembly. If there are any issues. Contact us: [customerservice@homsee.com](mailto:customerservice@homsee.com)

# Lista de Piezas

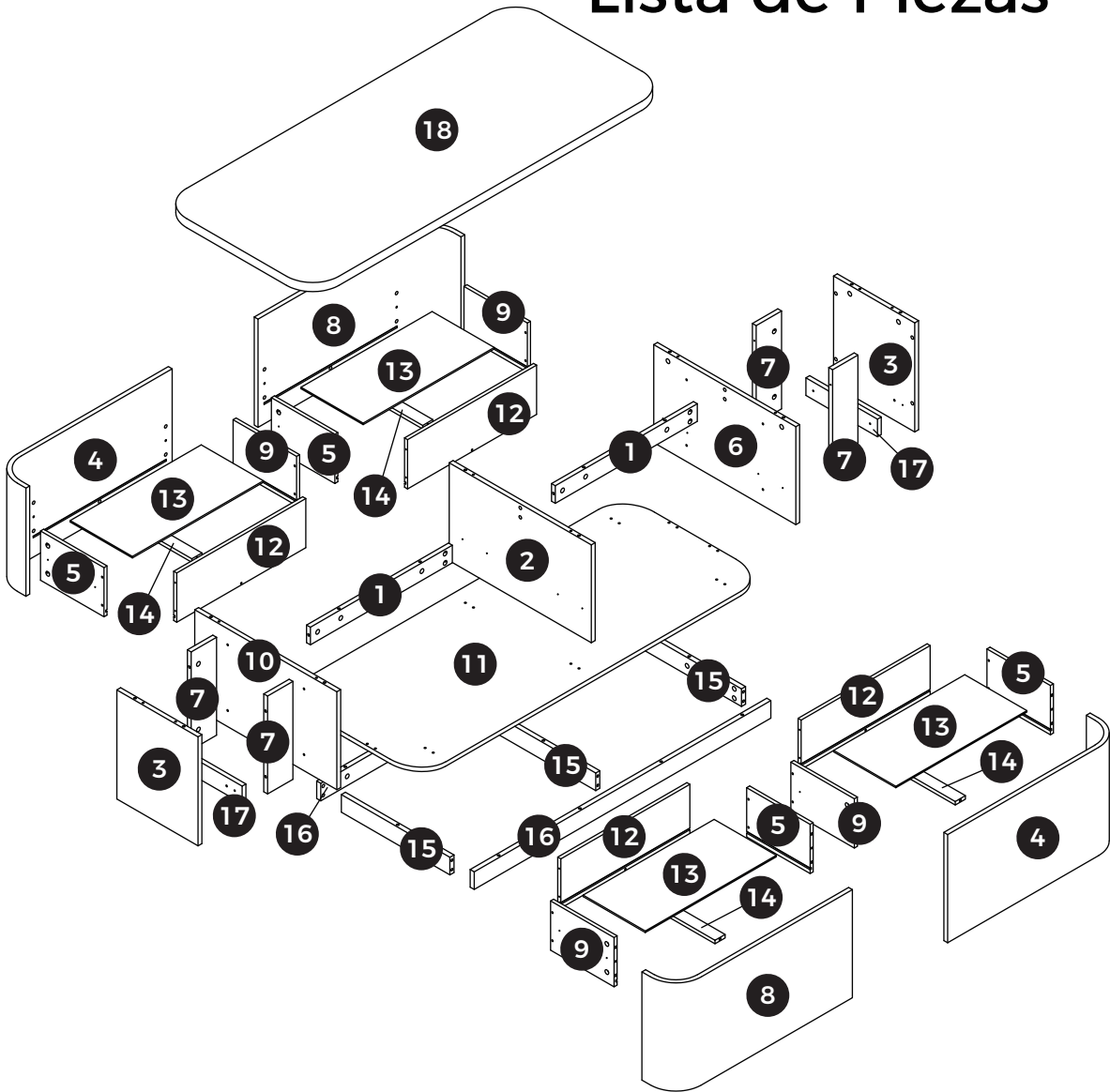

## ⚠ ADVERTENCIA



Los niños han muerto por el vuelco de muebles. Para reducir el riesgo de que el mueble se vuelque:

- SIEMPRE instala el dispositivo antivuelco incluido.
- NUNCA coloques un televisor sobre este producto.
- NUNCA permitas que los niños se suban, trepen o cuelguen de los cajones, puertas o estantes.
- NUNCA abras más de un cajón a la vez.
- Coloca los objetos más pesados en los cajones inferiores.

Esta es una etiqueta permanente.  
¡No la retires!



90 MINUTOS



2 ADULTOS



INTERMEDIO

Las piezas enumeradas arriba son necesarias para un montaje correcto. Si tienes algún problema, contáctanos en: [customerservice@homsee.com](mailto:customerservice@homsee.com)

# 01

[EN] Please note that this step is required for the following assembly steps.

Insert the pre-installed fitting (A) into the hole and ensure it is fully seated and flush with the panel surface.

Screw the cam bolt (B) vertically into fitting (A) and tighten clockwise.

[ES] Tenga en cuenta que este paso es necesario para los siguientes pasos de montaje.

Inserte el herraje (A) en el orificio y asegúrese de que esté completamente asentado y al ras de la superficie del panel.

Enrosque el perno excéntrico (B) verticalmente en el herraje (A) y apriételo en el sentido de las agujas del reloj.

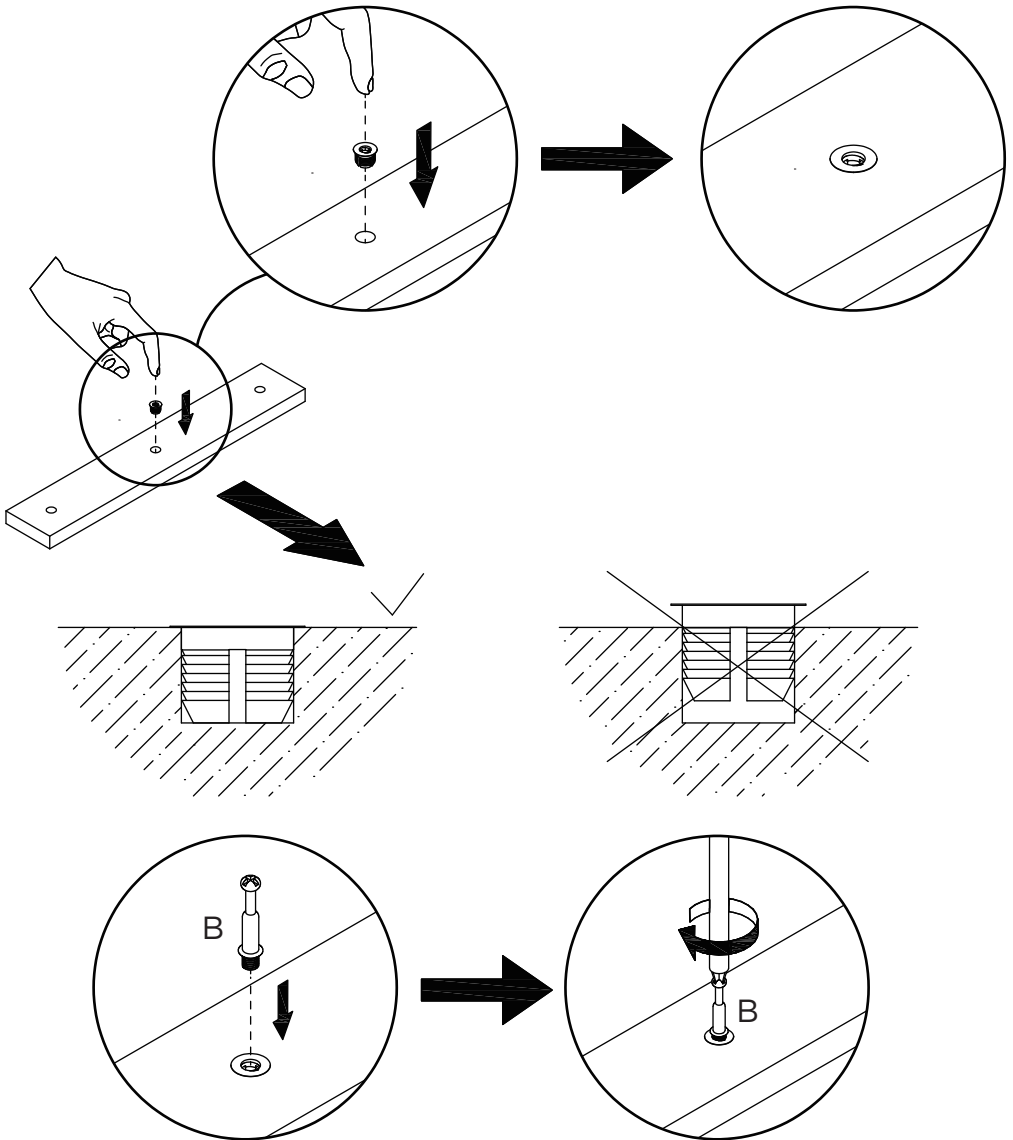

# 02

[EN] Locate the release lever on the inner side of slide rail **E1**. Push the **E1** lever inward or upward with your finger, then pull slide rail **E2** outward to detach it.

[ES] Localice la palanca de liberación en el lado interior de la guía **E1**. **E1** Empuje la palanca hacia adentro o hacia arriba con el dedo y luego tire de la guía **E2** hacia afuera para separarla.

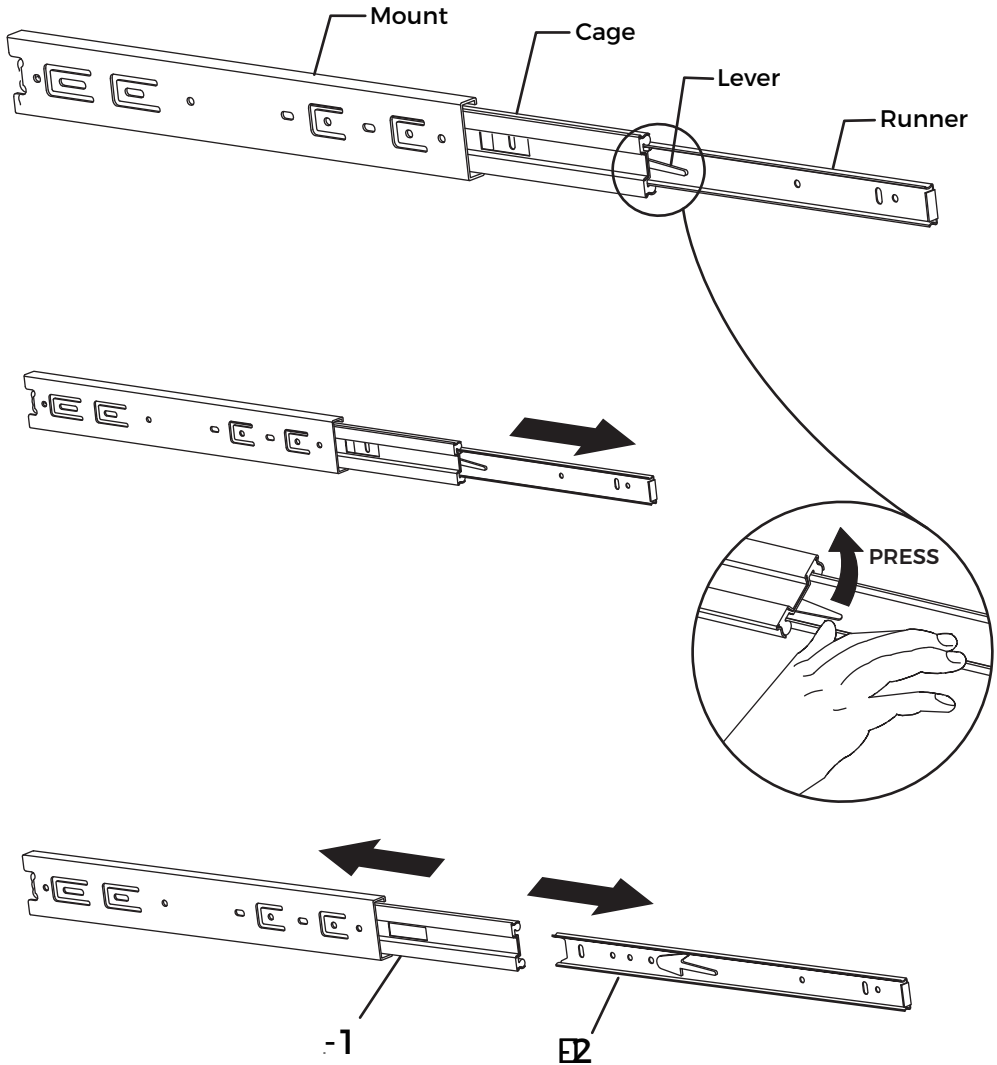

# 03

[EN] Push the damper release lever inward or upward to retract the damper.

[ES] Empuje la palanca de liberación del amortiguador hacia adentro o hacia arriba para retraer el amortiguador.

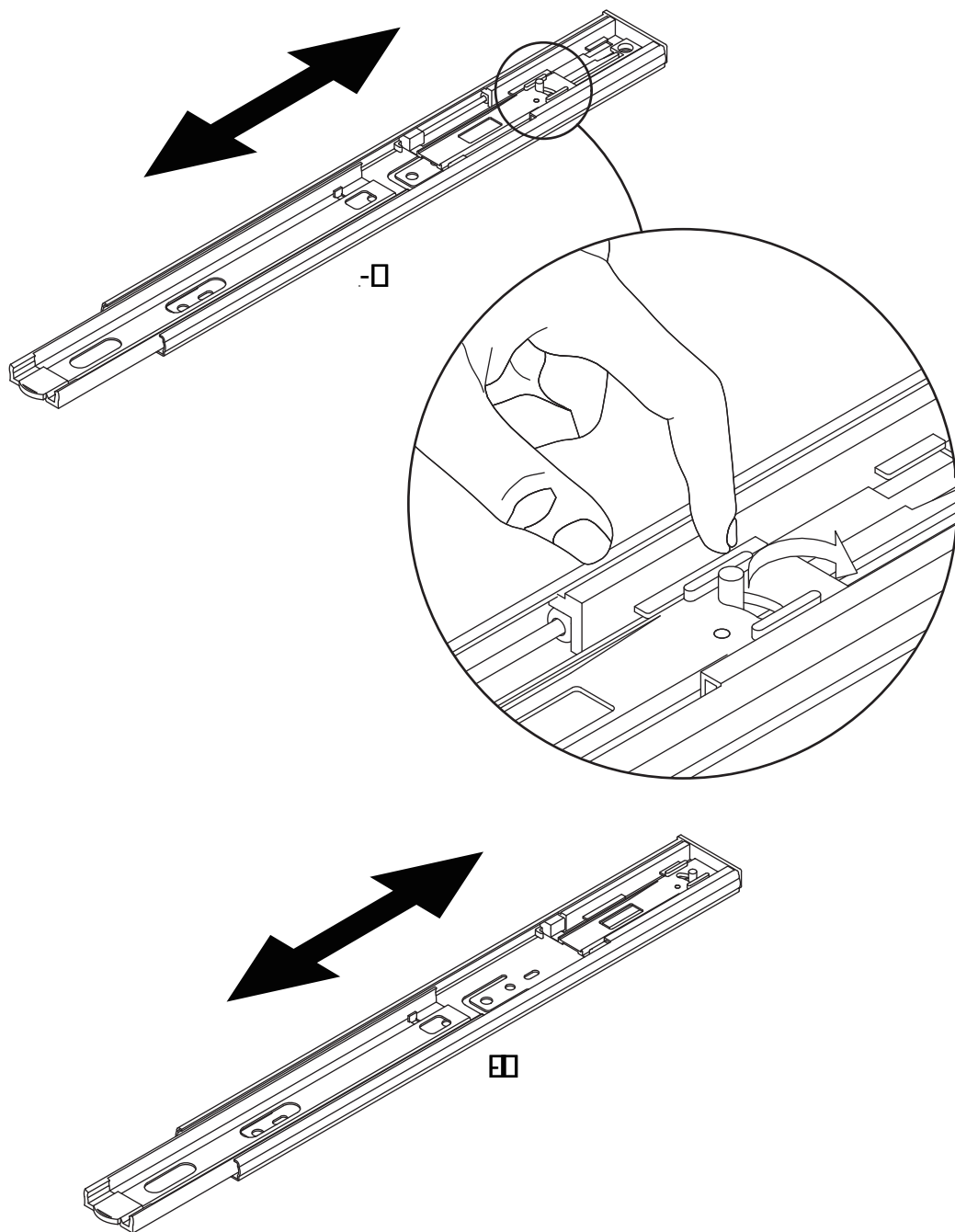

# 04



[EN] Connect panel 17 to panel 3 using wooden dowel (D), and secure with screws (H).

[ES] Conecta el panel 17 al panel 3 usando el espiga de madera (D) y asegúralo con los tornillos (H).

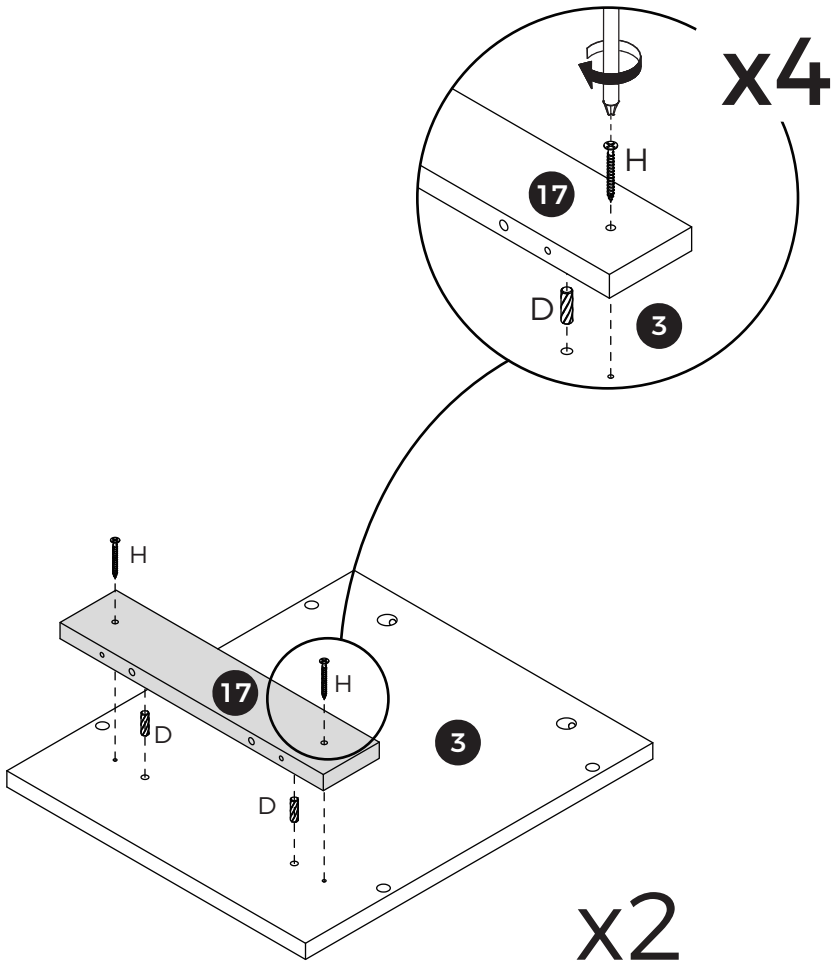

# 05



[EN] Install plug (E) onto panel 3, then screw the self-tapping rod (B) into panel 3.

[ES] Instala el tapón (E) en el panel 3 y luego atornilla la varilla autorroscante (B) en el panel 3.

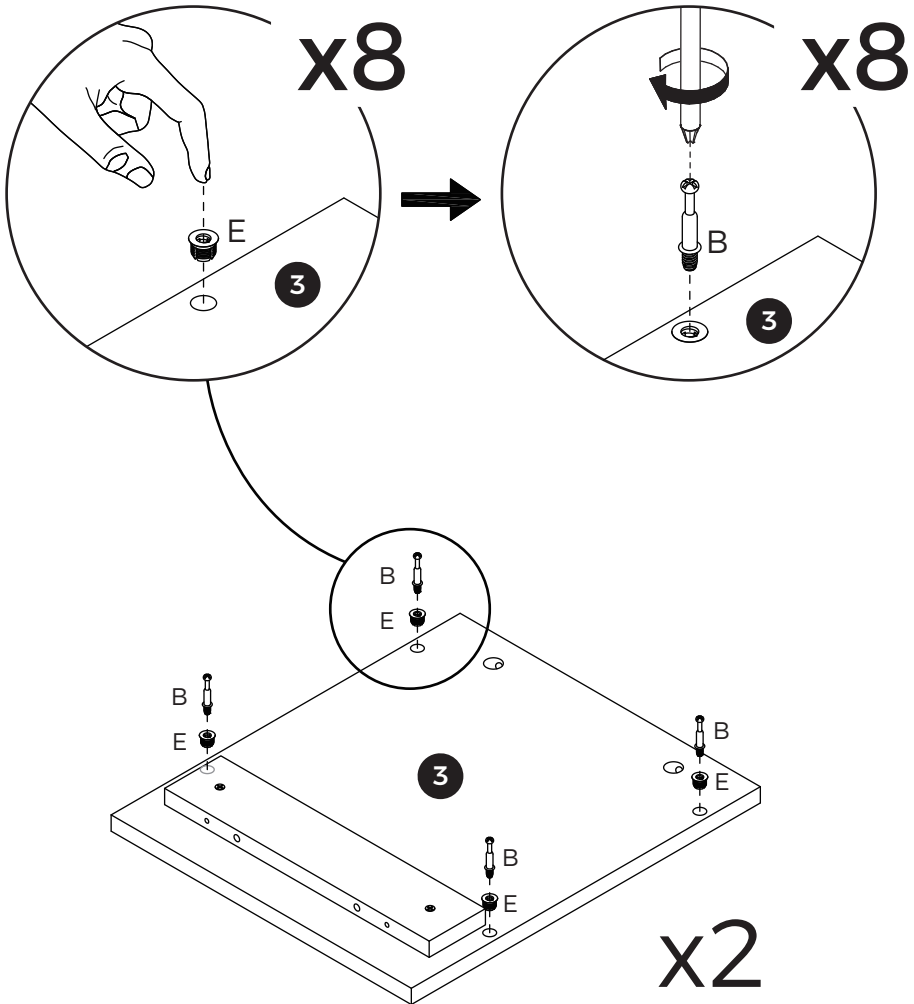

# 06



[EN] Connect panel 7 to panel 3, and tighten by turning the eccentric wheel (A) clockwise as shown.

[ES] Conecta el panel 7 al panel 3 y aprieta girando la rueda excéntrica (A) en el sentido de las agujas del reloj, como se muestra.

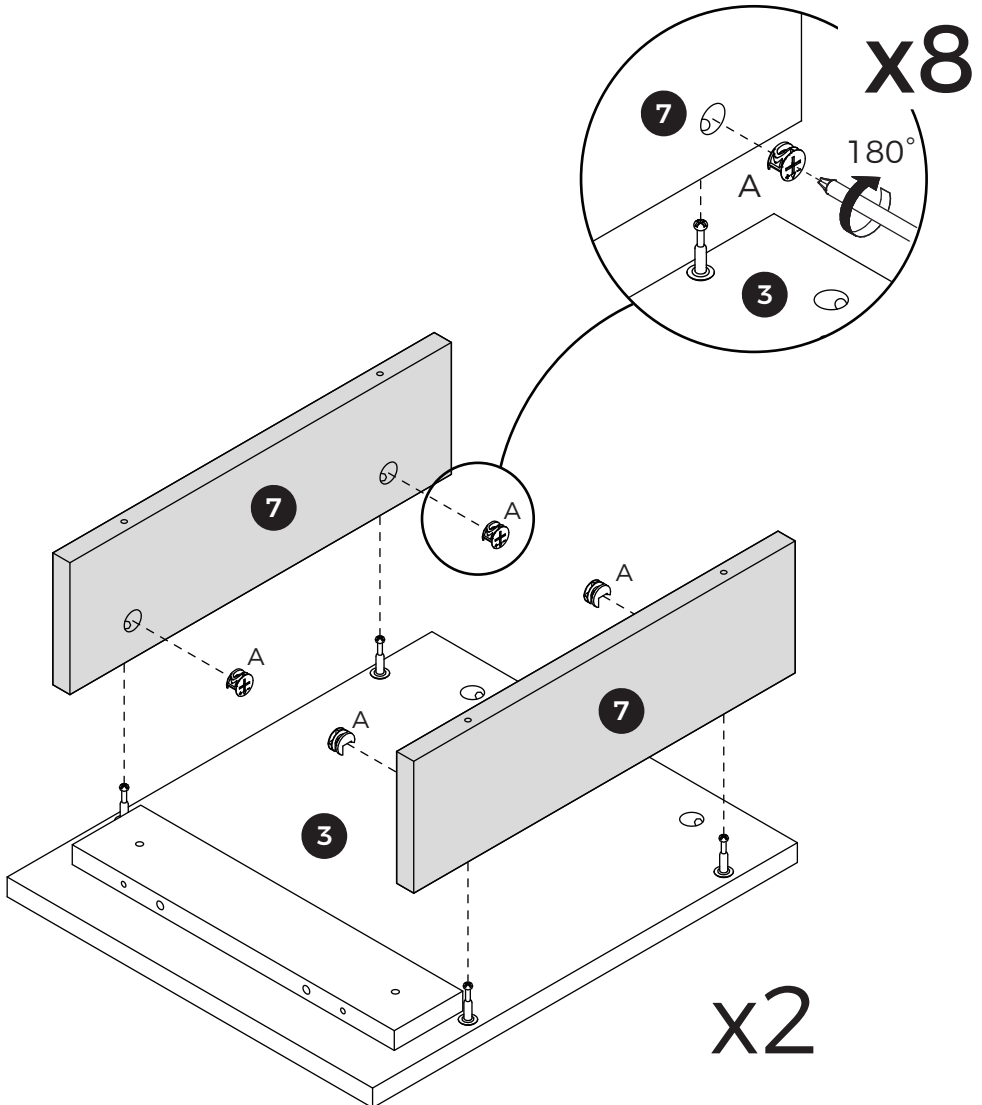

# 07



[EN] Install plug (E) onto panel 18, then screw the self-tapping rod (B) into panel 18.

[ES] Instala el tapón (E) en el panel 18 y luego atornilla la varilla autorroscante (B) en el panel 18.

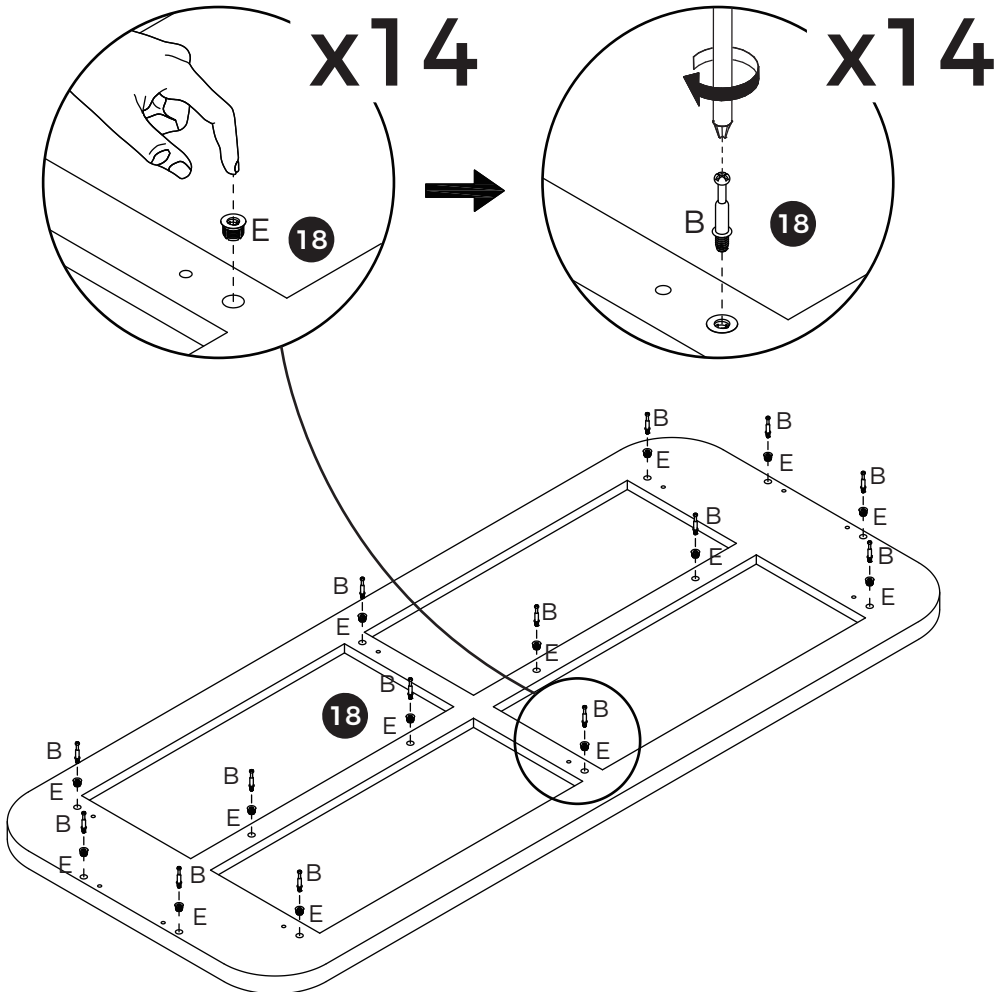

# 08



[EN] Connect panel 3 to panel 18 using wooden dowel (C), and tighten by turning the eccentric wheel (A) clockwise as shown.

[ES] Conecta el panel 3 al panel 18 usando la espiga de madera (C) y aprieta girando la rueda excéntrica (A) en el sentido de las agujas del reloj, como se muestra.

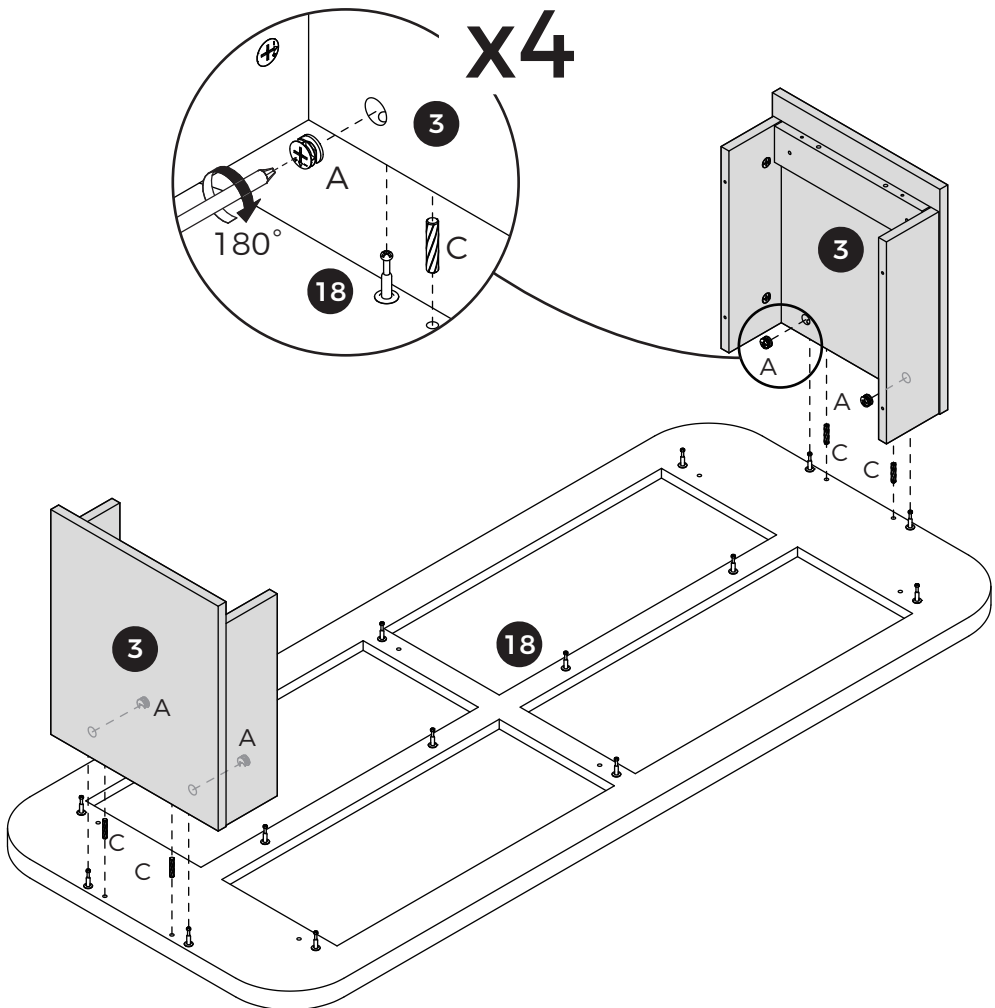

# 09



[EN] Secure slide rail J (J-1) to panel 10 using screw (G).

[ES] Fija la guía deslizante J (J-1) al panel 10 usando el tornillo (G).

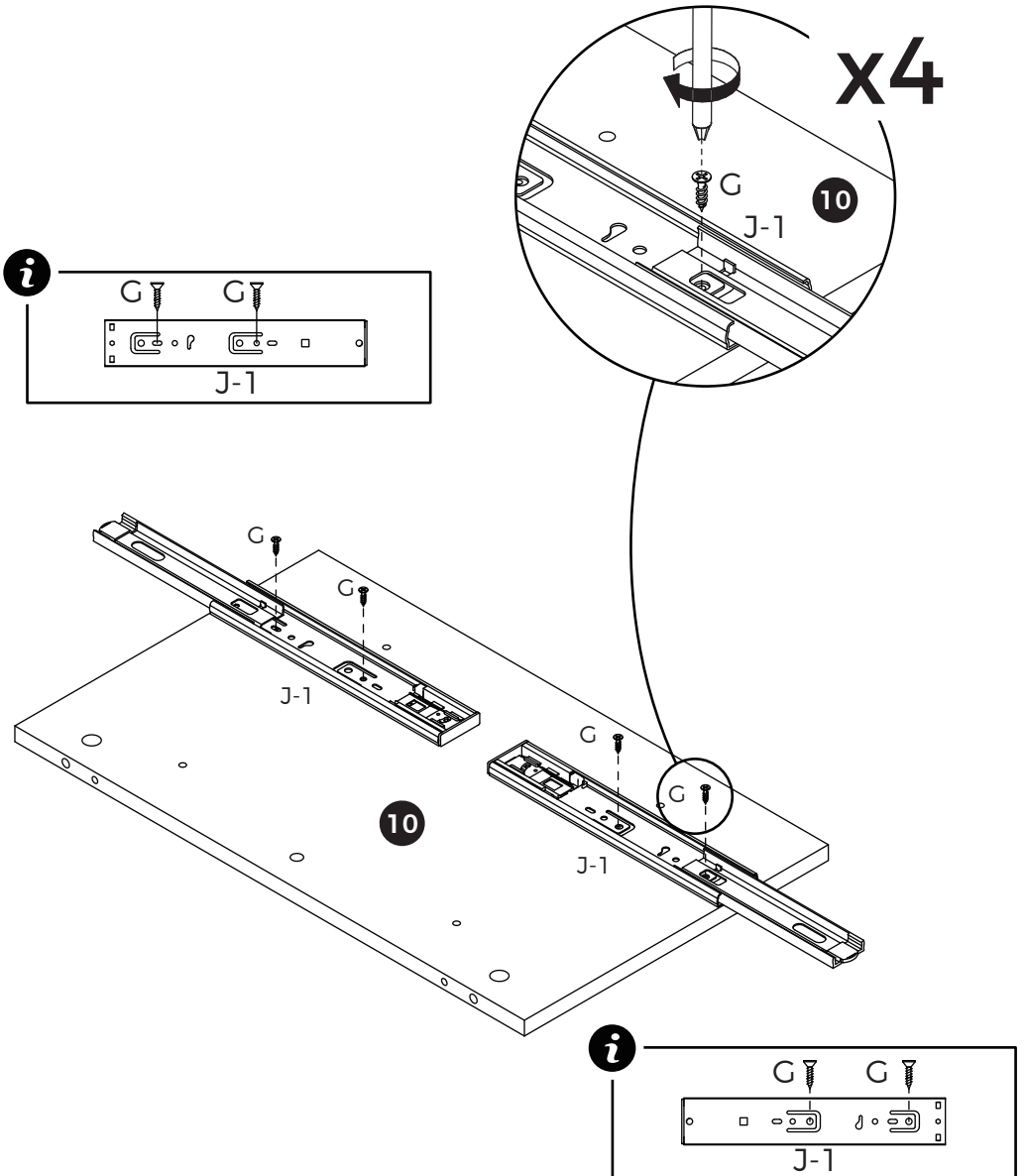

# 10



[EN] Install plug (E) onto panel 10, then screw the self-tapping rod (B) into panel 10.

[ES] Instala el tapón (E) en el panel 10 y luego atornilla la varilla autorroscante (B) en el panel 10.

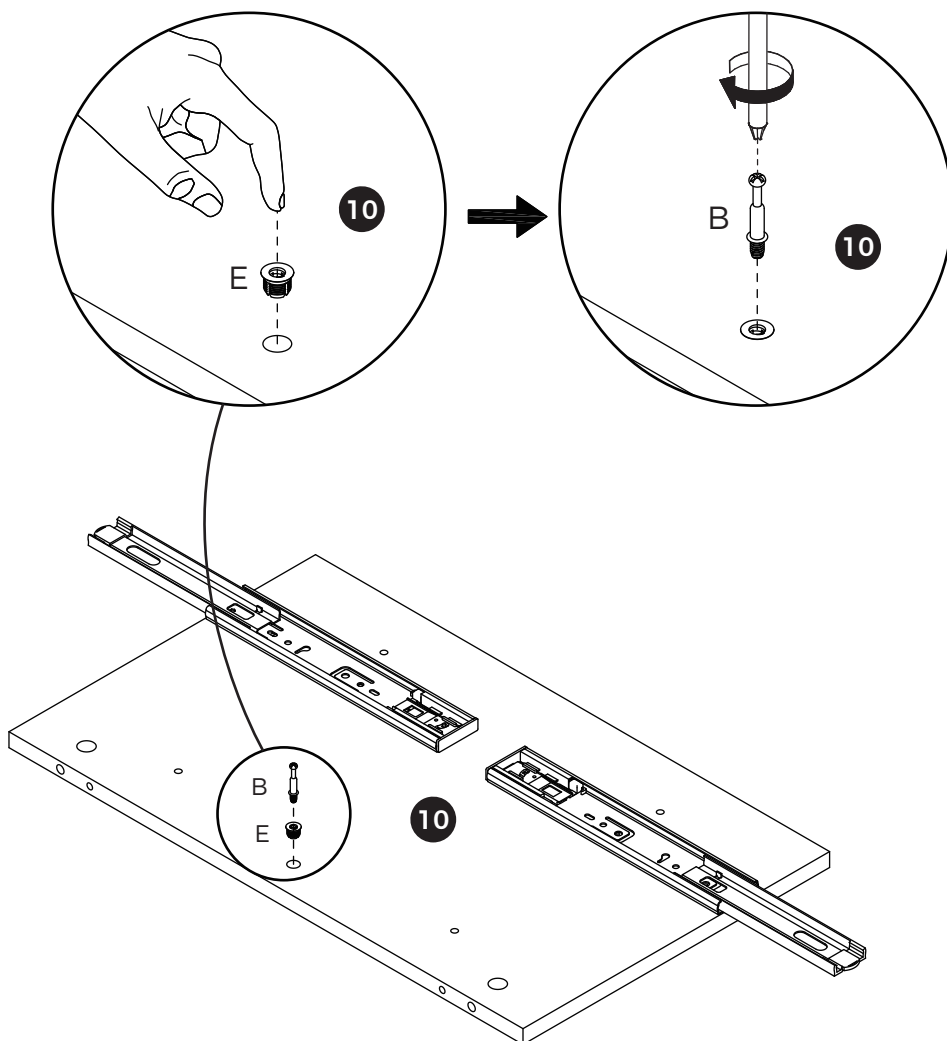



[EN] Secure slide rail J (J-1) to panel 2 using screw (G).

[ES] Fija la guía deslizante J (J-1) al panel 2 usando el tornillo (G).

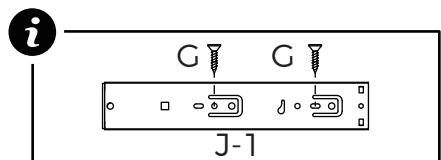
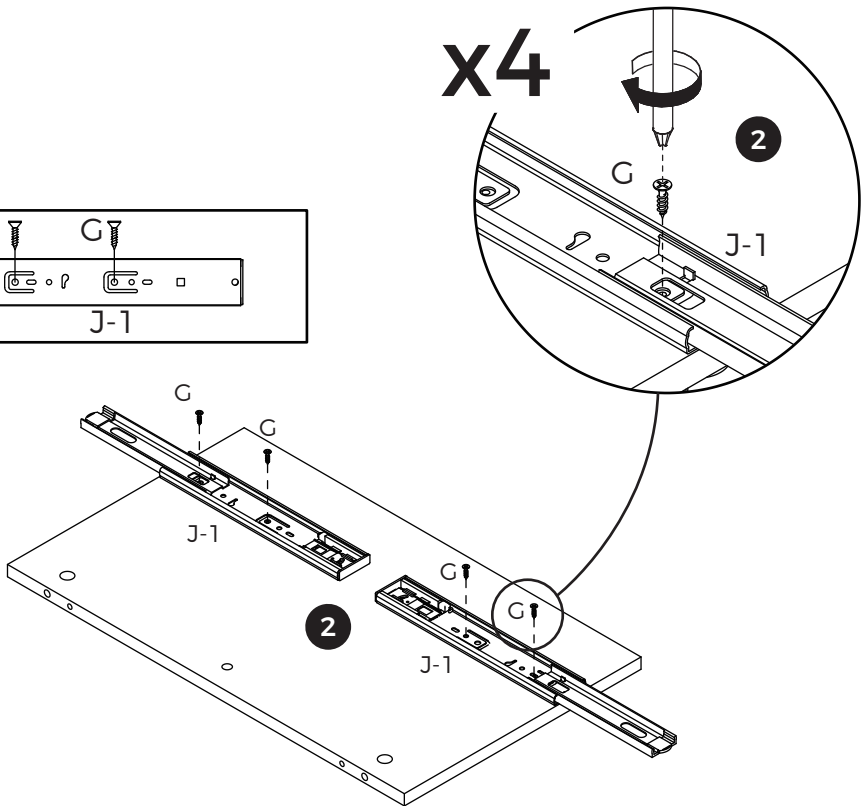
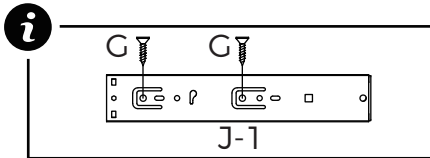

# 12



[EN] Install plug (E) onto panel 2.

[ES] Instala el tapón (E) en el panel 2.

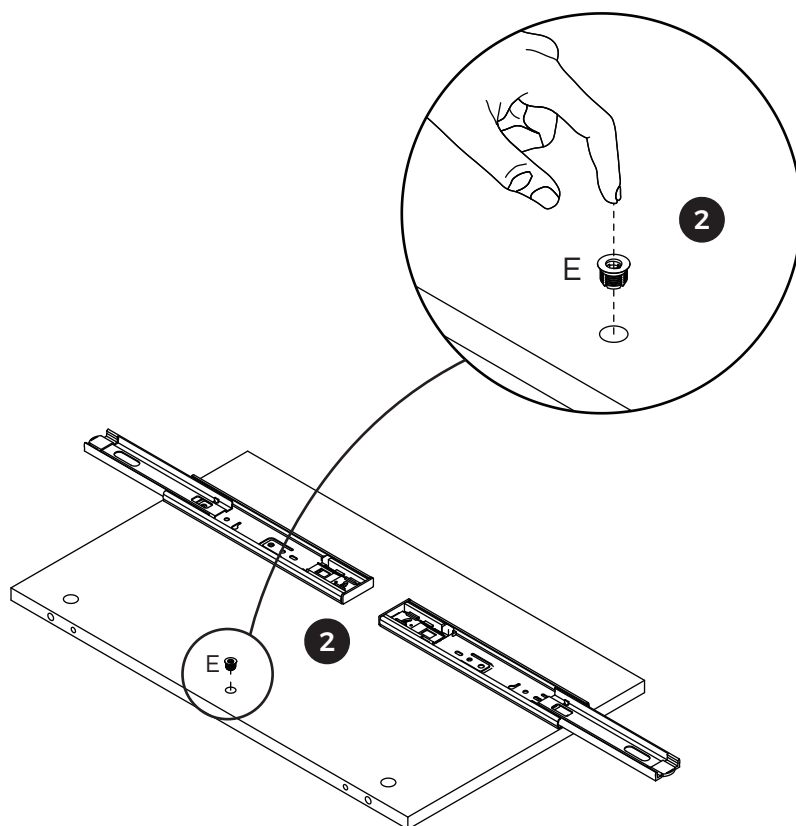

# 13



[EN] **Flip panel 2 to the back**, then secure slide rail J (J-1) to it using screw (G).

[ES] **Gira el panel 2 hacia el lado posterior** y fija la guía deslizante J (J-1) con el tornillo (G).

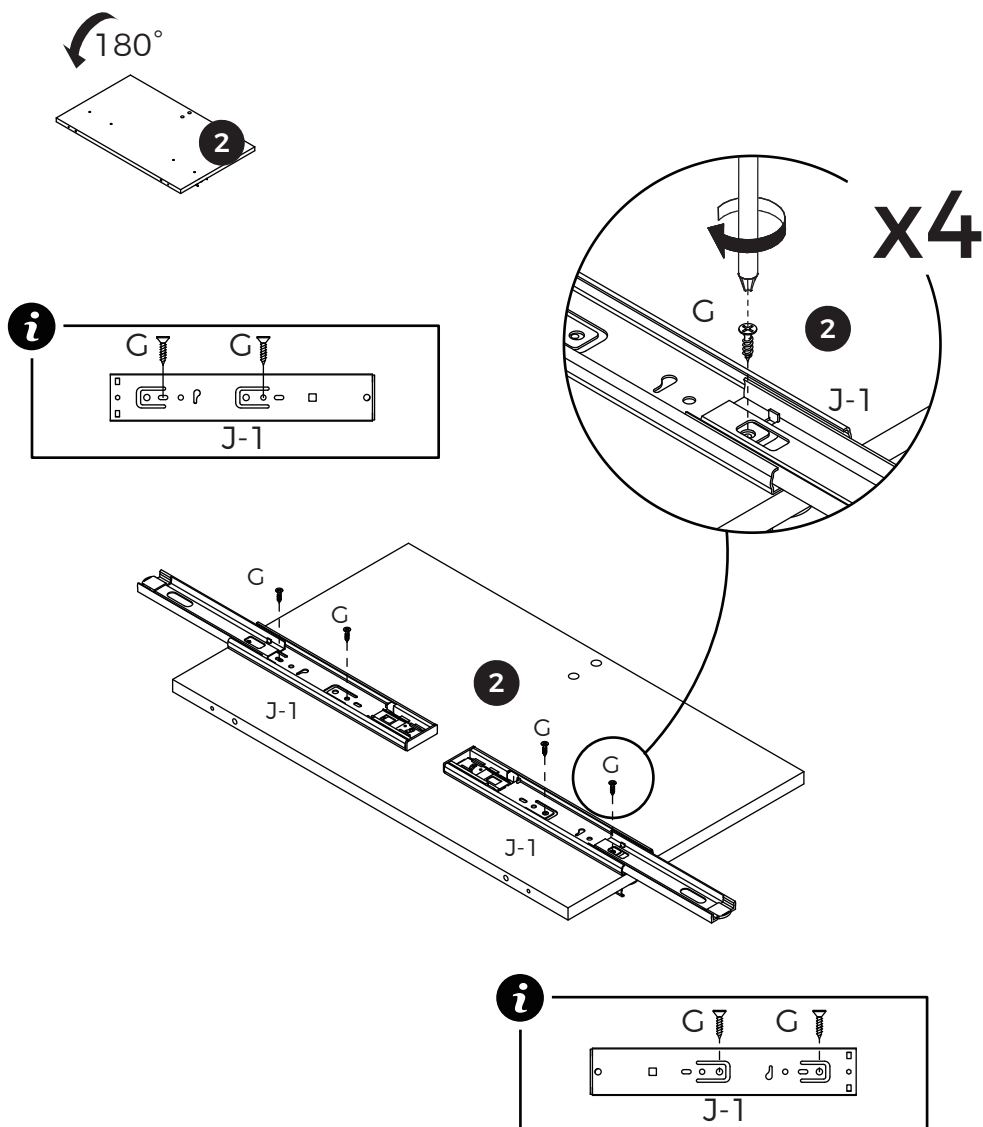

# 14



[EN] Install plug (E) onto panel 2, then screw the self-tapping rod (B) into panel 2.

[ES] Instala el tapón (E) en el panel 2 y luego atornilla la varilla autorroscante (B) en el panel 2.

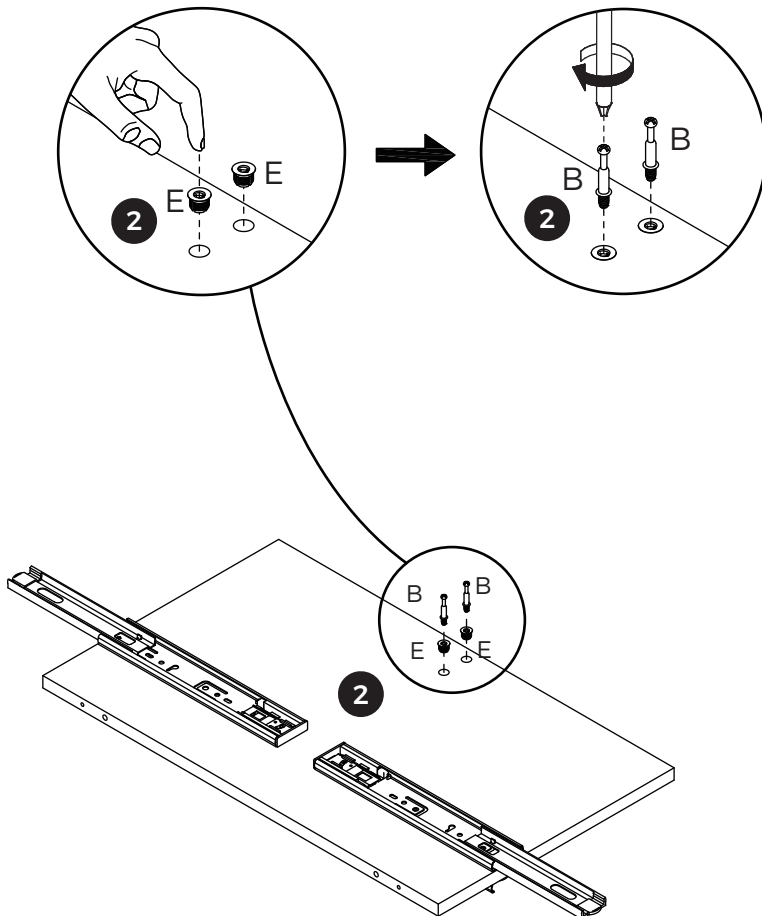

# 15

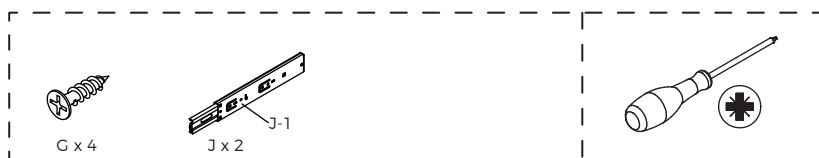

[EN] Secure slide rail J (J-1) to panel 6 using screw (G).

[ES] Fije el riel deslizante J (J-1) al panel 6 con el tornillo (G).

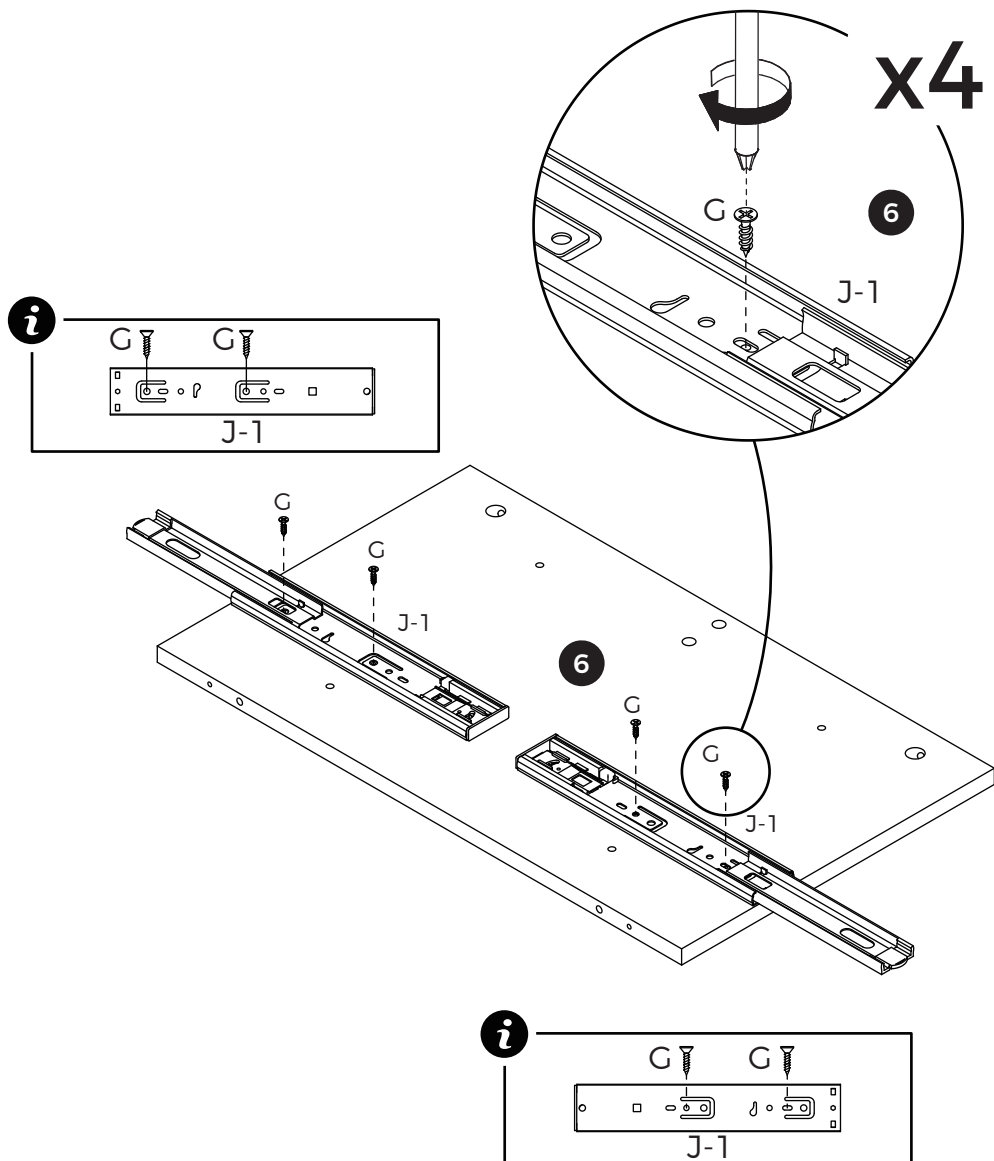

# 16



[EN] Install plug (E) onto panel 6, then screw the self-tapping rod (B) onto panel 6.

[ES] Instale el enchufe (E) en el panel 6 y luego atornille la varilla autorroscante (B) en el panel 6.

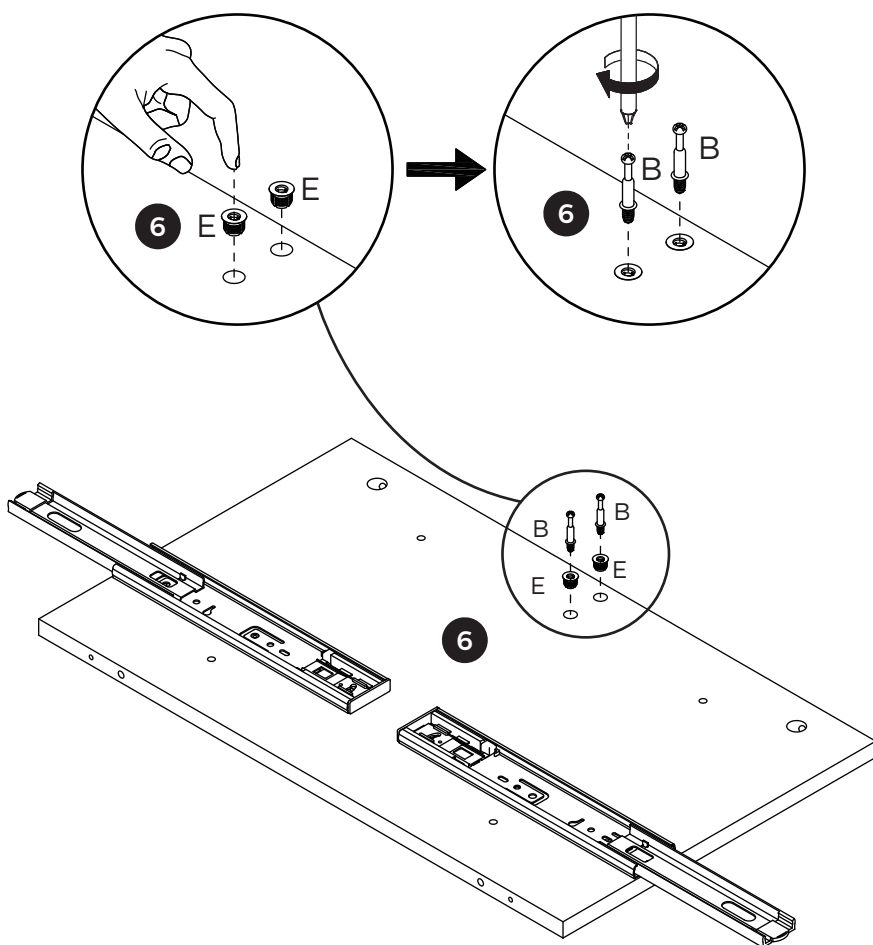

# 17



[EN] Connect panels 2 and 10 to panel 1, and tighten by turning eccentric wheel (A) clockwise as shown.

[ES] Conecte los paneles 2 y 10 al panel 1 y apriete girando la rueda excéntrica (A) en sentido horario, como se muestra.

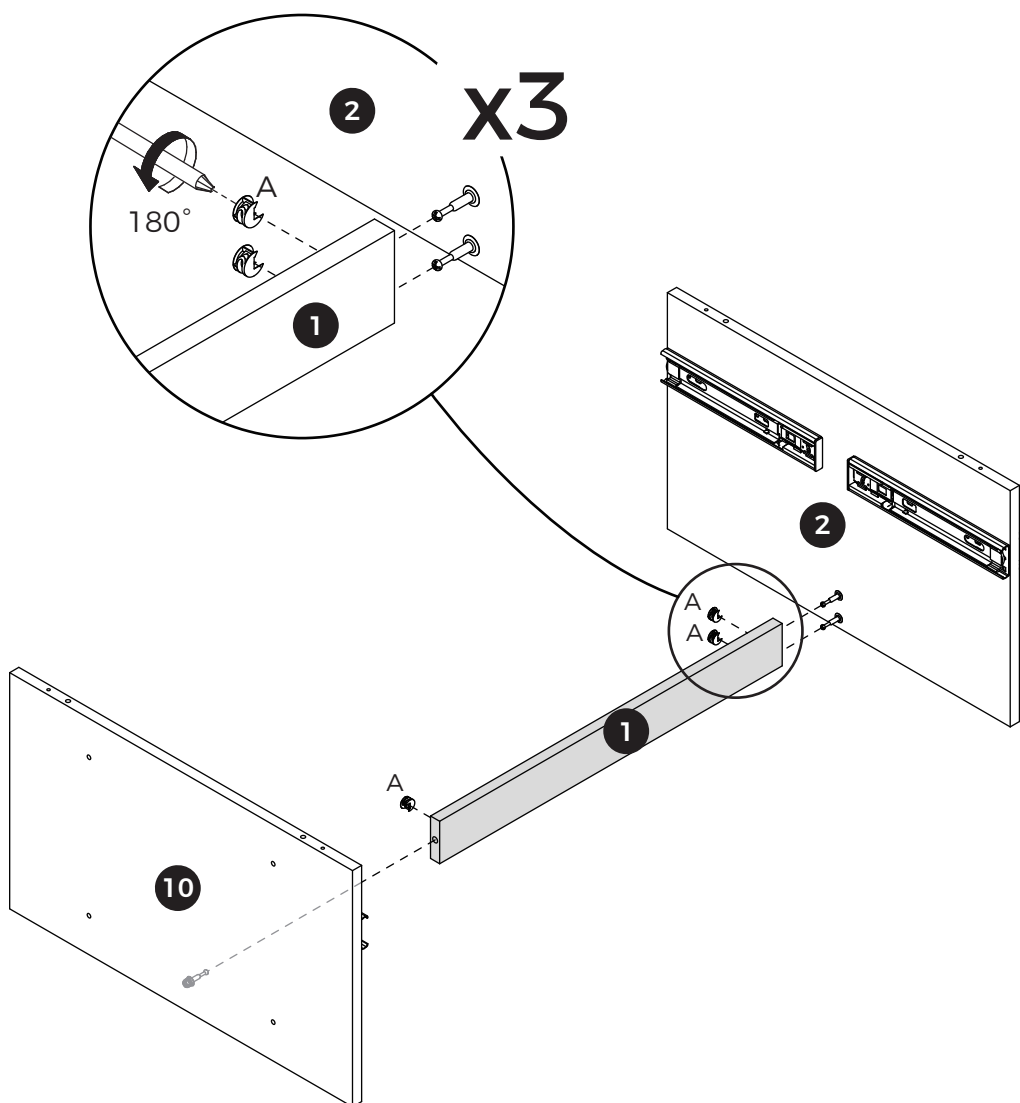

# 18



[EN] Screw the self-tapping rod (B) onto panel 2.

[ES] Atornille la varilla autorroscante (B) en el panel 2.

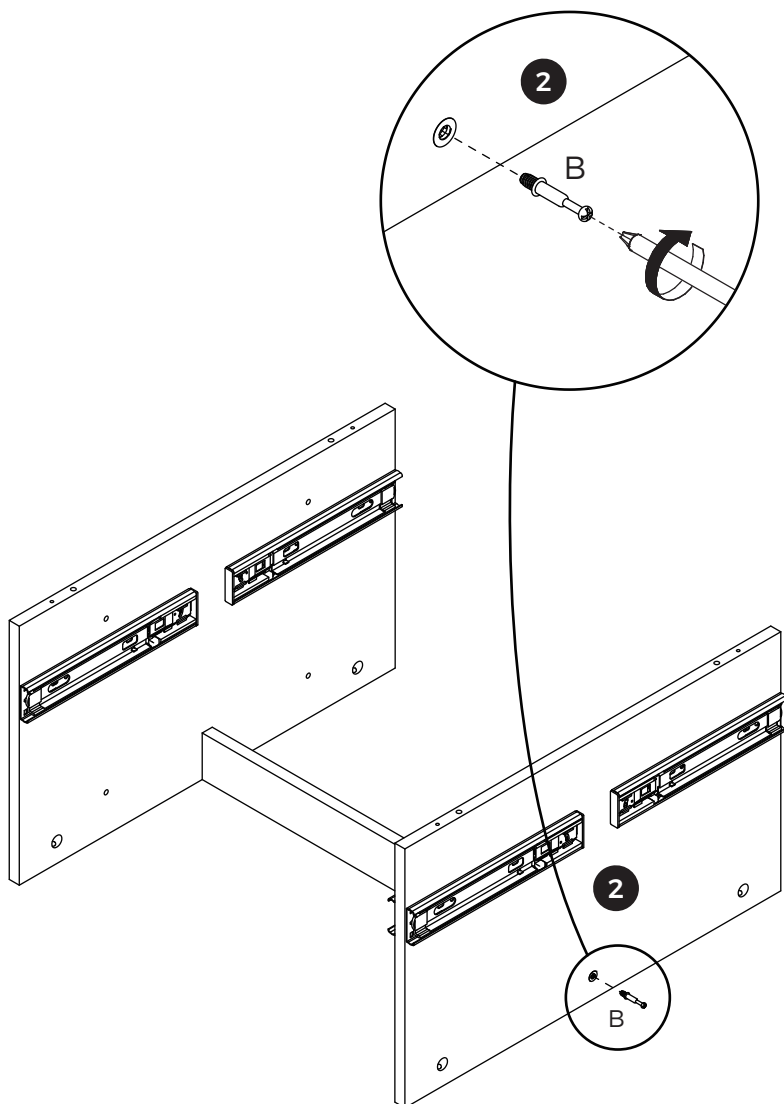

# 19

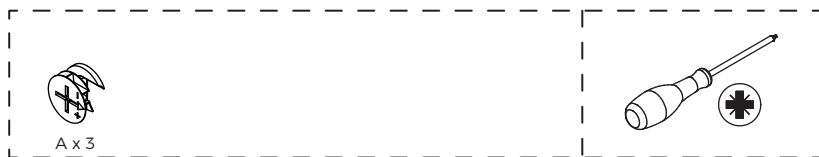

[EN] Connect panels 2 and 6 to panel 1, and tighten by turning eccentric wheel (A) clockwise as shown.

[ES] Conecte los paneles 2 y 6 al panel 1 y apriete girando la rueda excéntrica (A) en sentido horario, como se muestra.

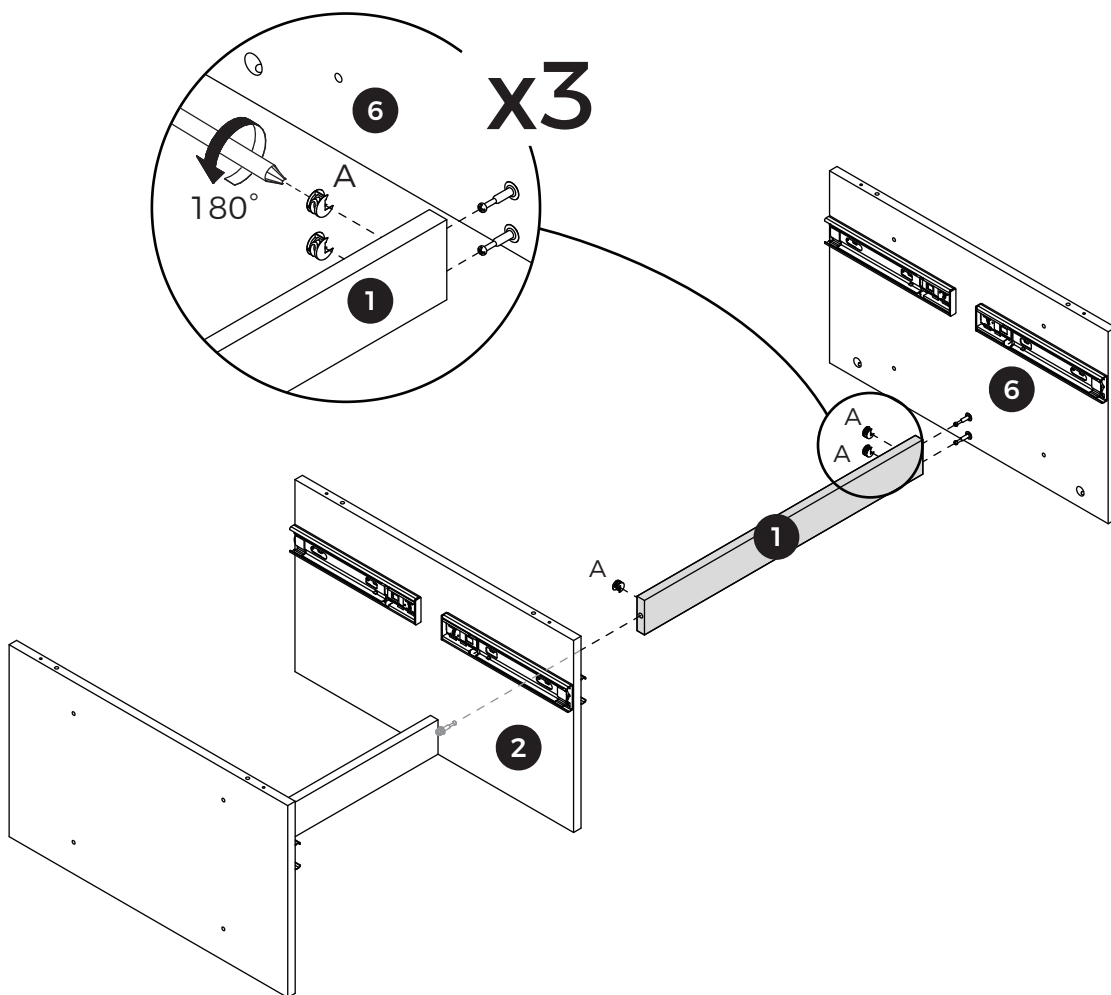

# 20



[EN] Connect panel 11 to panels 6, 2, and 10 using wooden dowel (C), and secure with screws (F).

[ES] Conecte el panel 11 con los paneles 6, 2 y 10 usando el espigo de madera (C) y fíjelo con los tornillos (F).

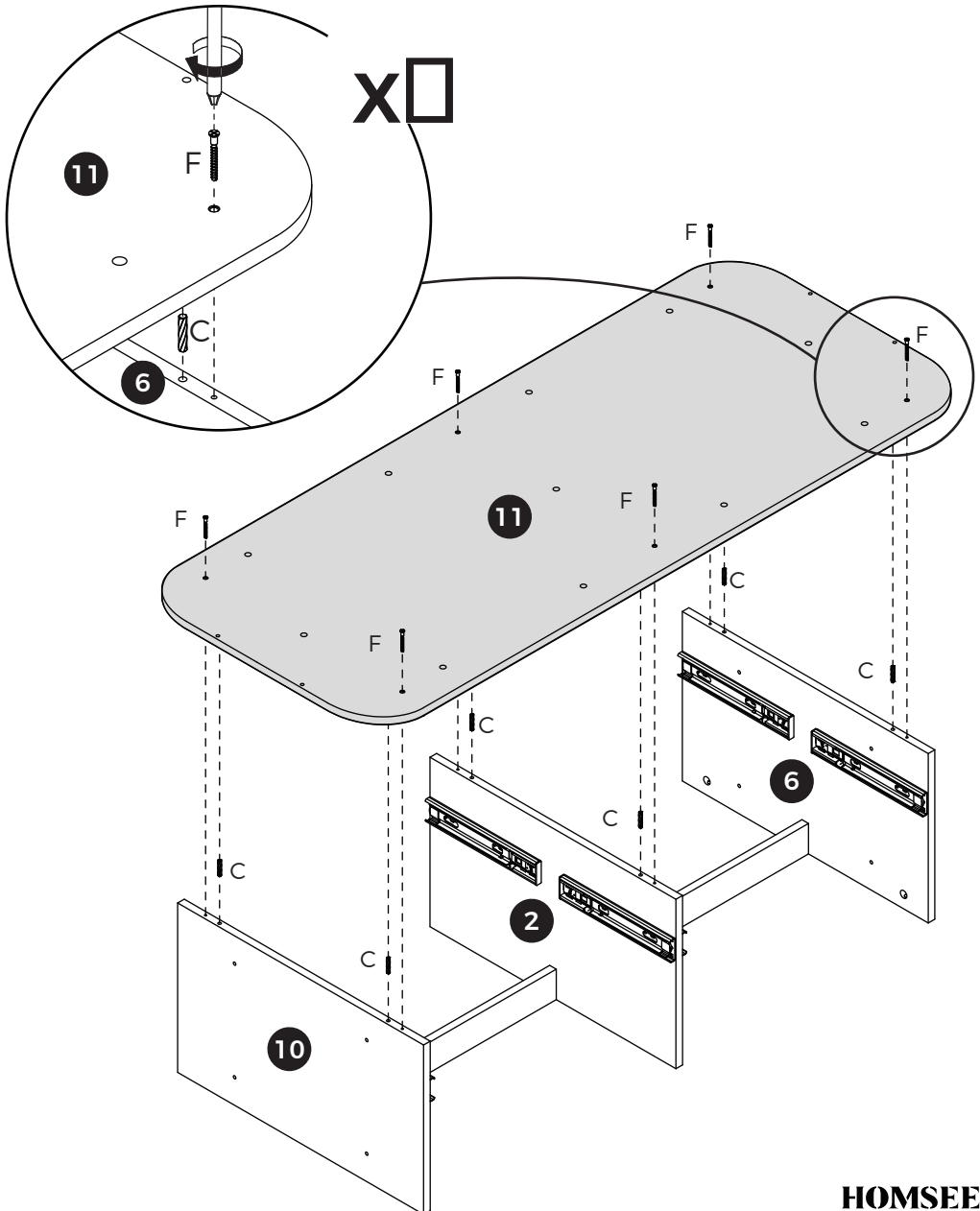

# 21



[EN] Insert wooden dowel (C) into panels 17 and 18.

[ES] Inserte el espigo de madera (C) en los paneles 17 y 18.

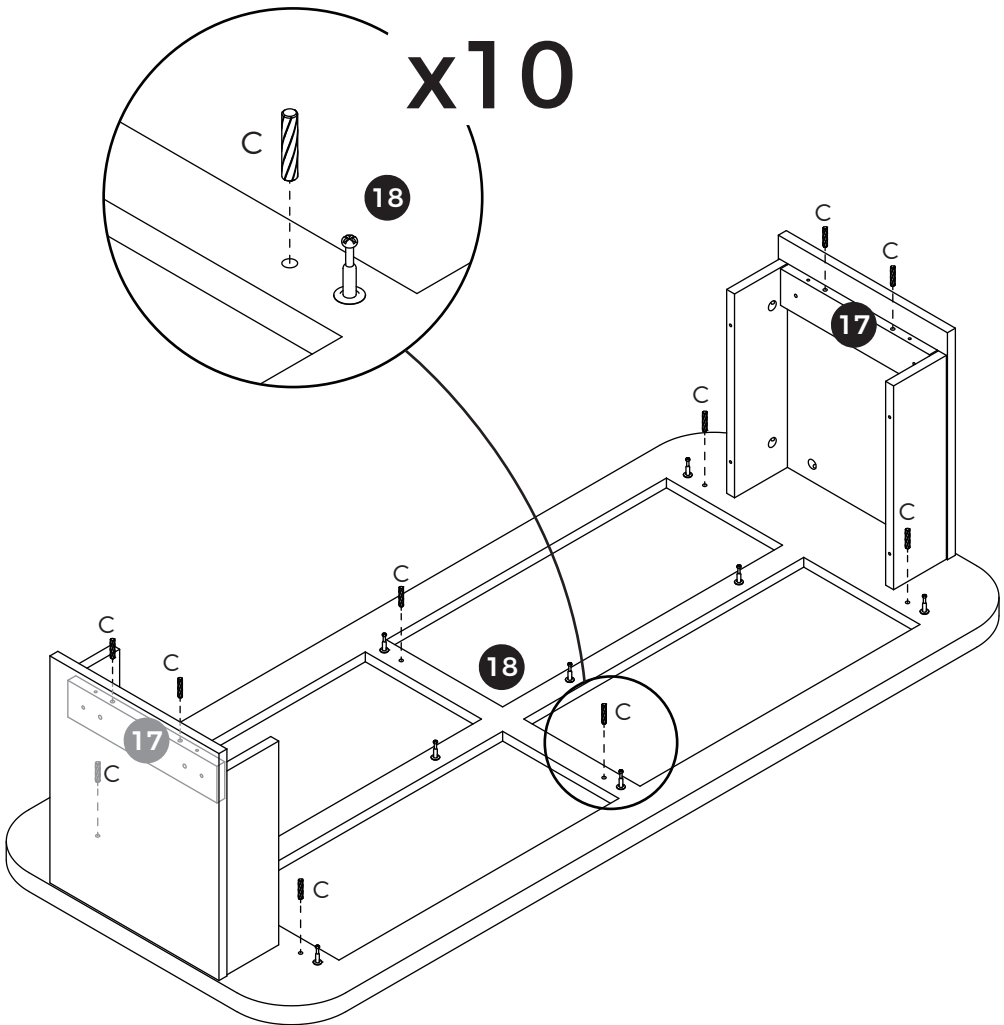



# 23



[EN] Install eccentric wheel (A) onto panels 1, 2, 6, and 10.  
Turn clockwise as shown.

[ES] Instale la rueda excéntrica (A) en los paneles 1, 2, 6 y 10.  
Gírela en sentido horario como se muestra.

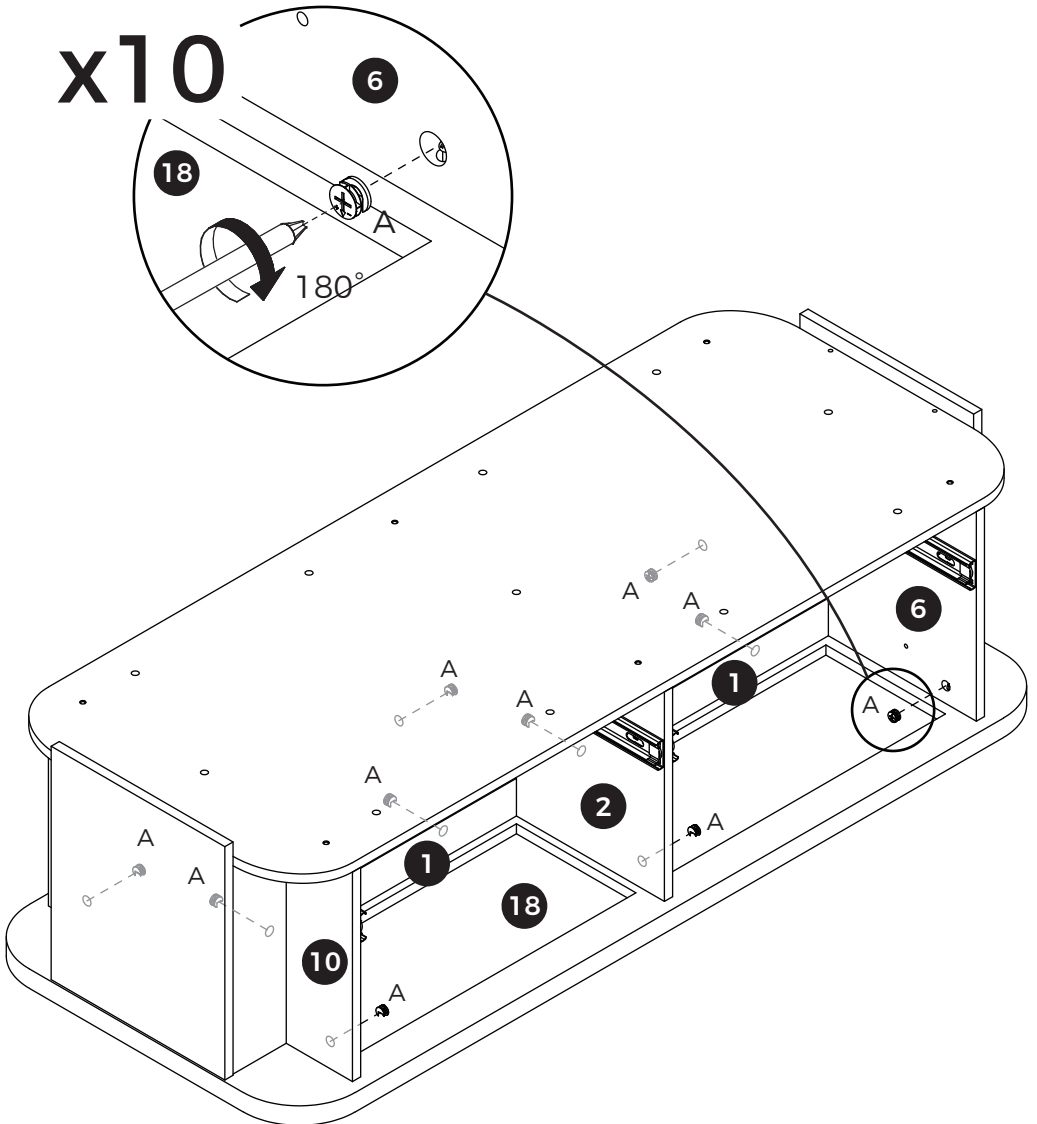

# 24



[EN] Connect panels 6 and 10 to panel 7 and secure with screws (F).

[ES] Conecte los paneles 6 y 10 al panel 7 y fjelos con los tornillos (F).

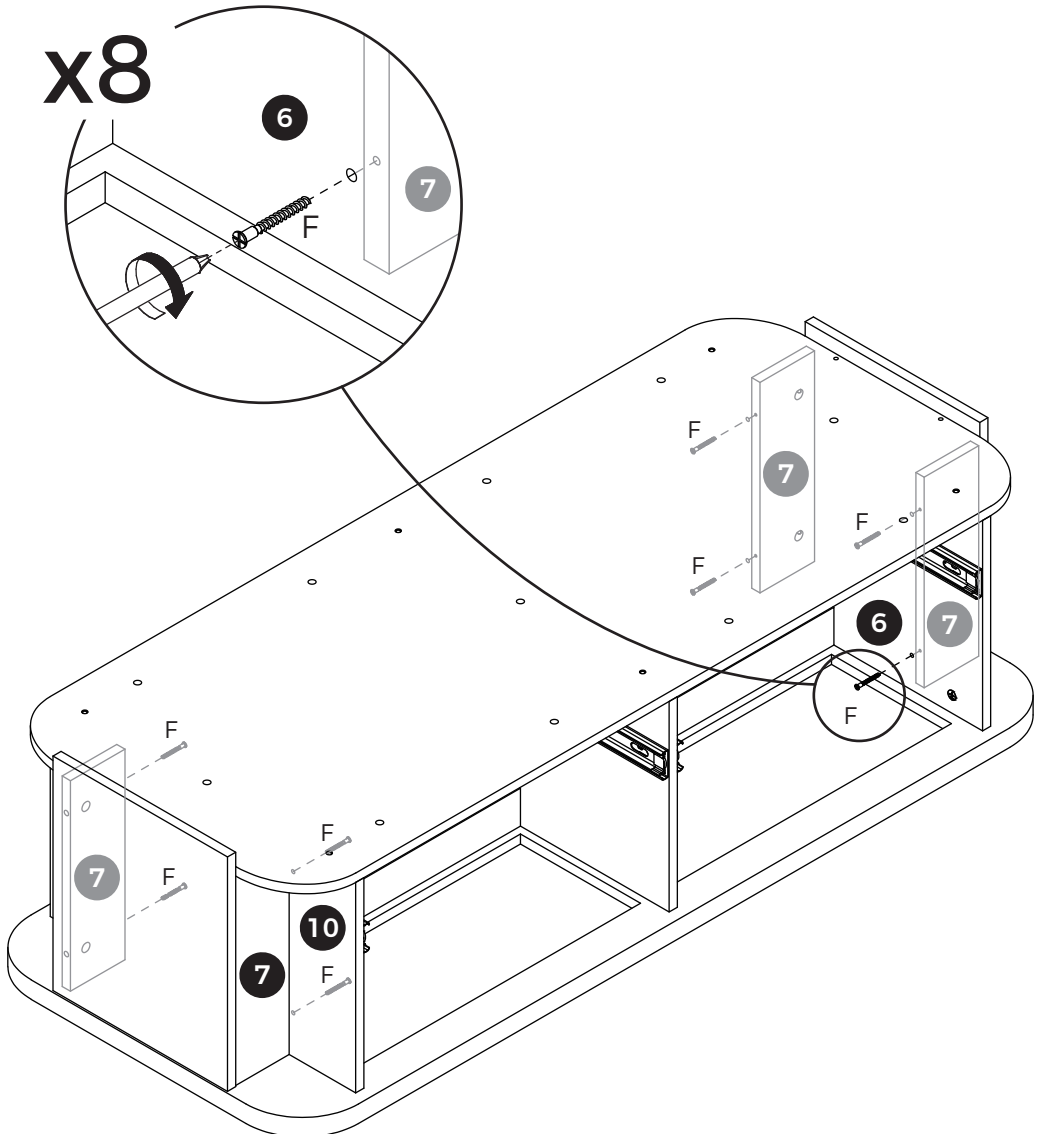

# 25



[EN] Install plug (E) onto panel 16, then screw the self-tapping rod (B) onto panel 16.

[ES] Instala el tapón (E) en el panel 16 y luego atornilla la varilla autorroscante (B) en el panel 16.

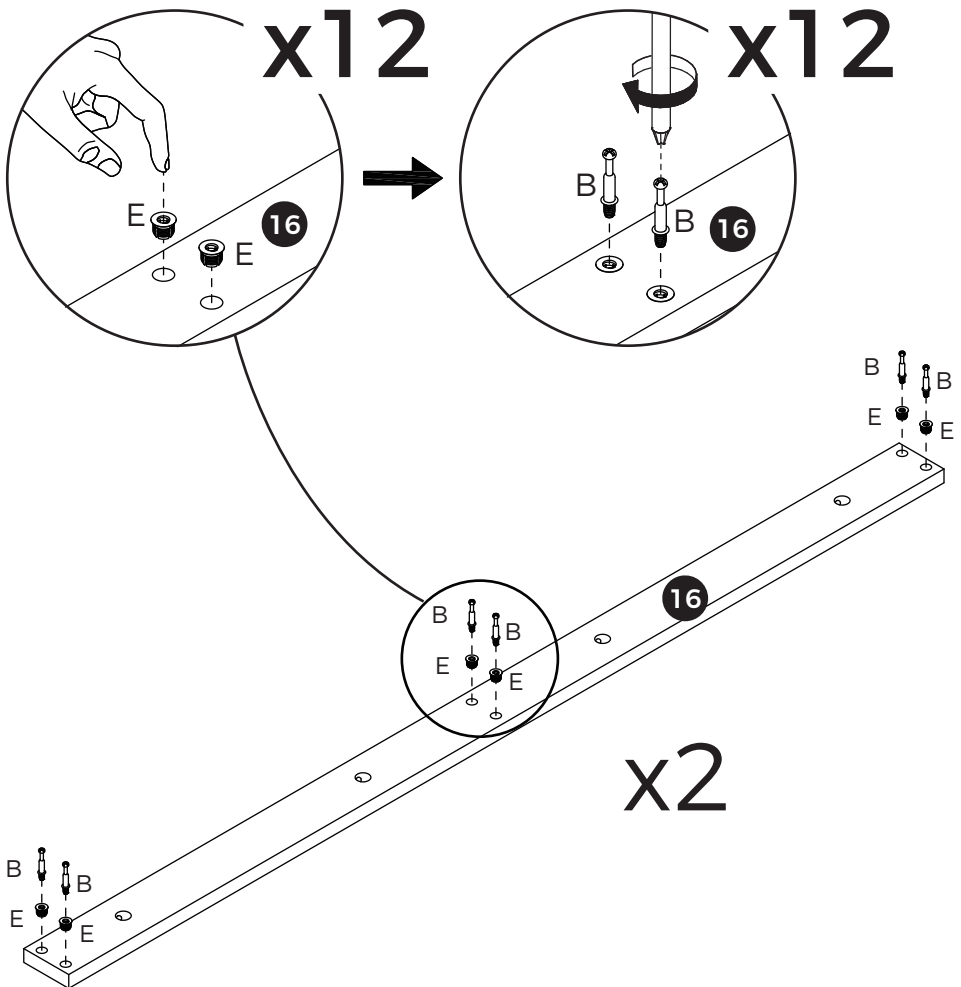





[EN] Install plug (E) onto panel 11, then screw the self-tapping rod (B) onto panel 11.

[ES] Instale el tapón (E) en el panel 11 y luego atornille la varilla autorroscante (B) en el panel 11.

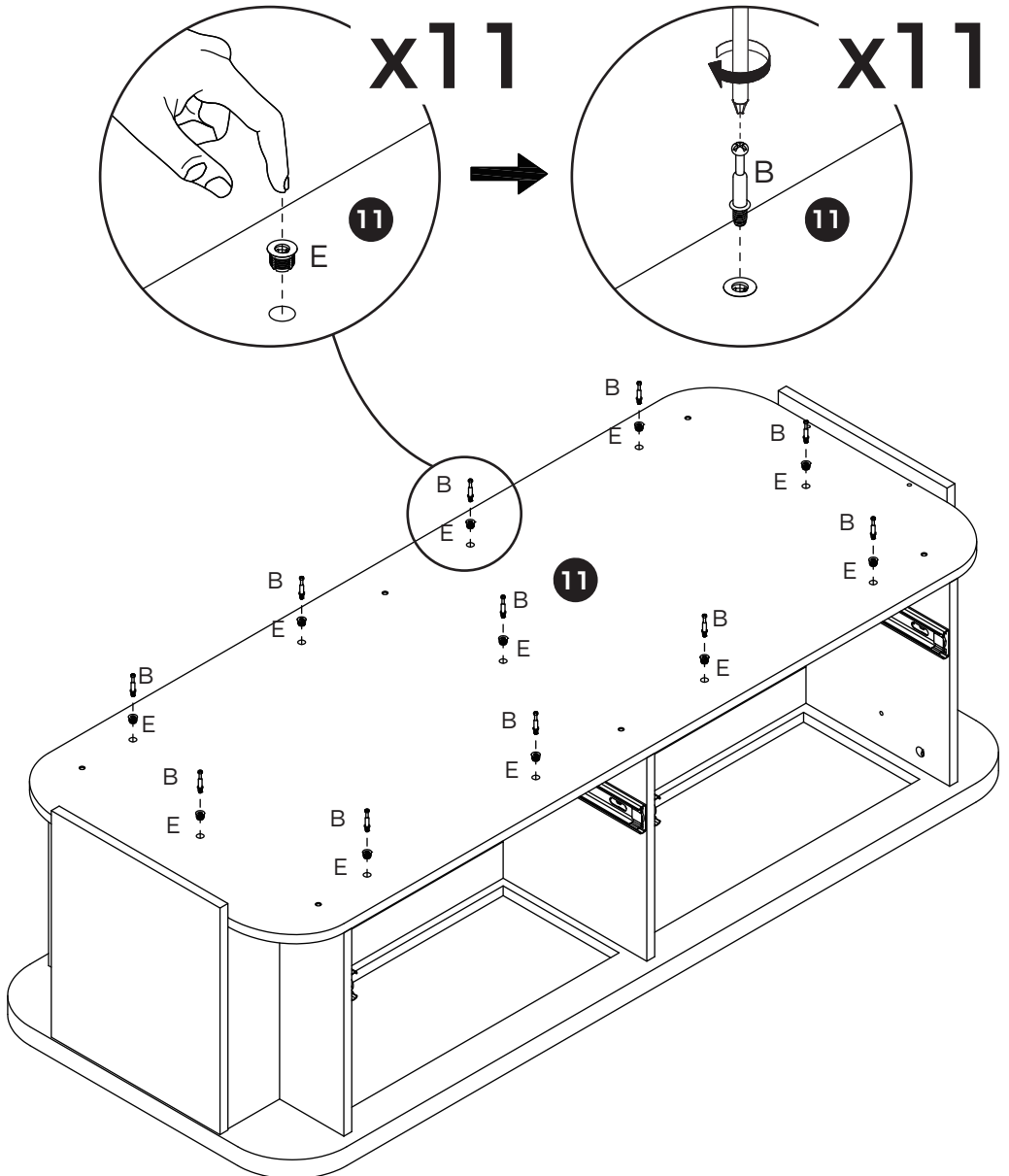



# 29



[EN] Secure slide rail J(J-2) to panels 5 and 9 with screws (G).

[ES] Fije la guía J(J-2) a los paneles 5 y 9 con los tornillos (G).

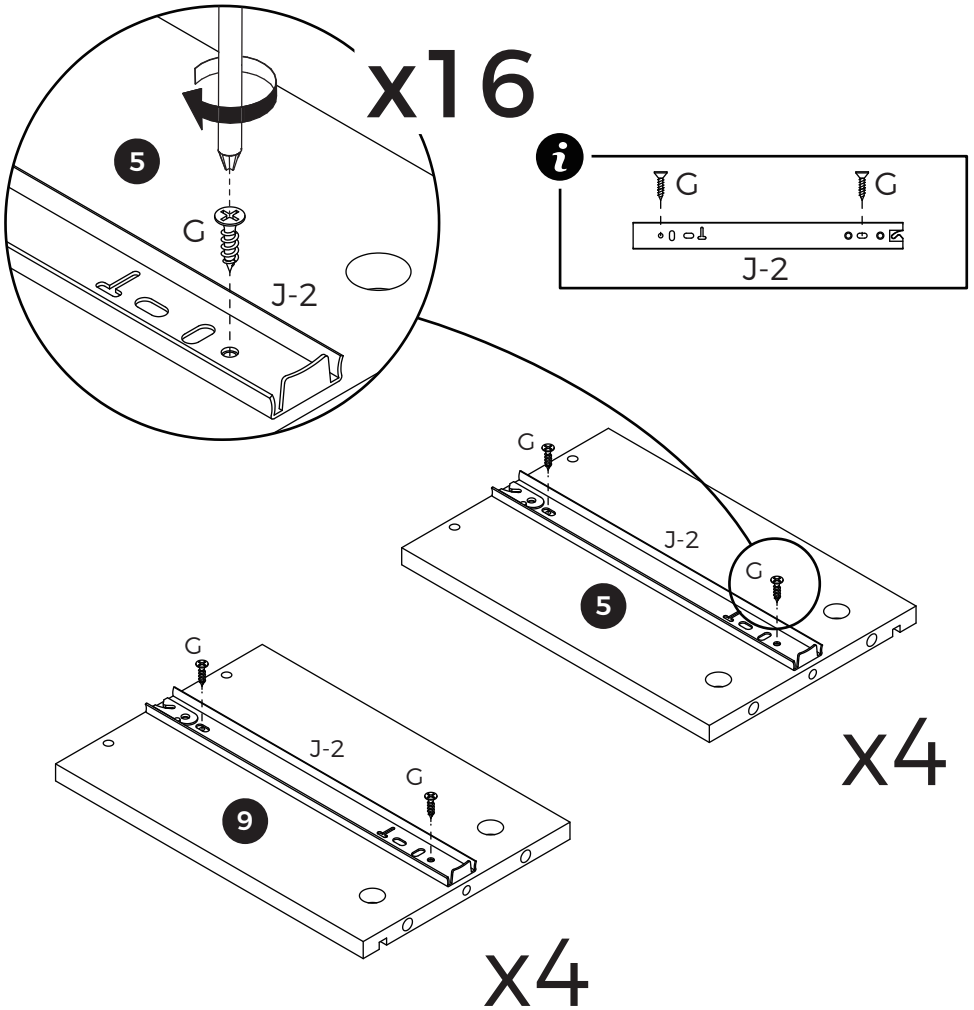

# 30



[EN] Connect panels 5, 9, and 14 to panel 12 with screw (F).  
Insert panel 13 into the slots.

[ES] Conecte los paneles 5, 9 y 14 al panel 12 con el tornillo (F).  
Inserte el panel 13 en las ranuras.

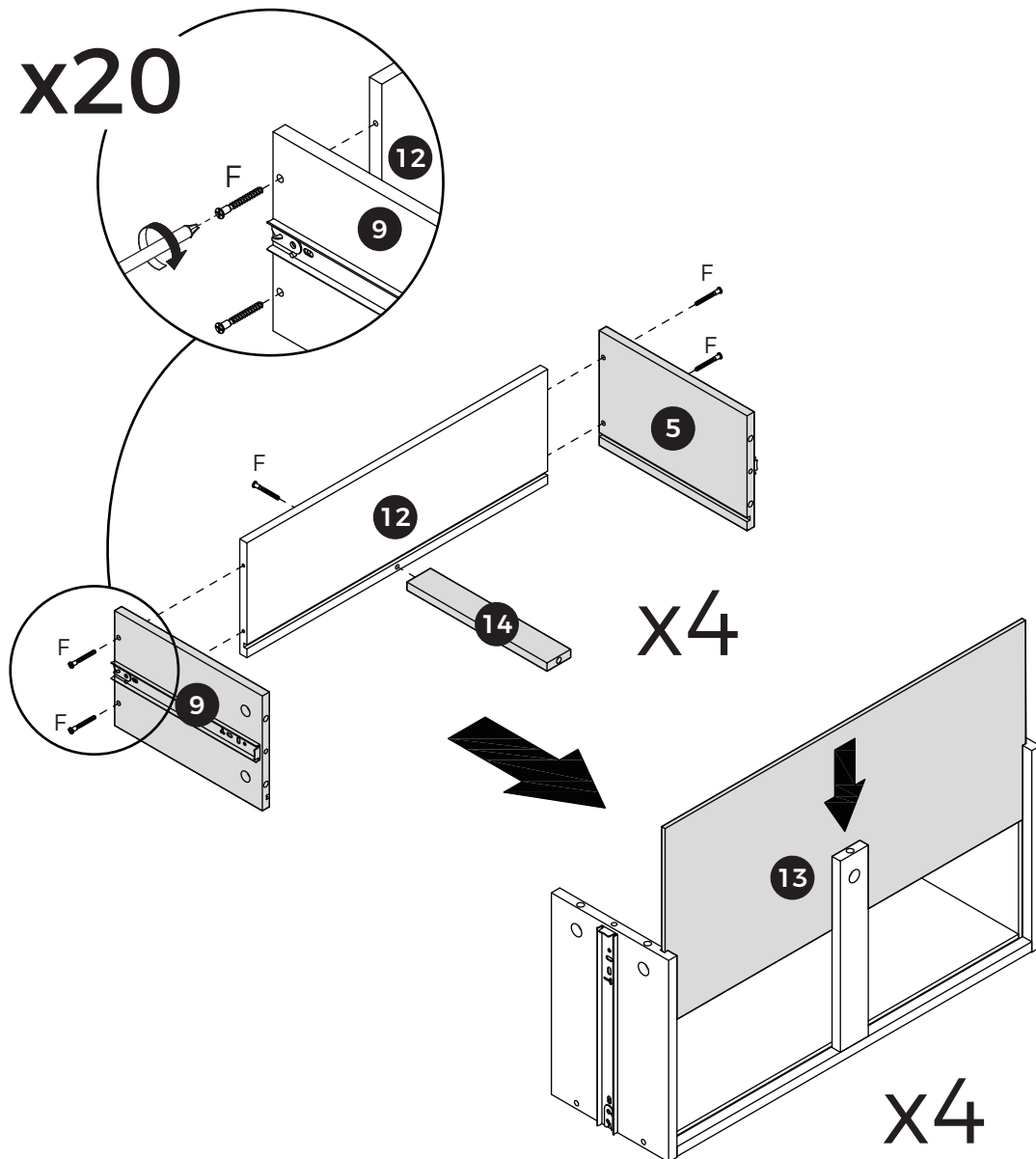

# 31



[EN] Install plug (E) on panels 4 and 8, then screw the self-tapping rod (B) in place.

[ES] Instale el tapón (E) en los paneles 4 y 8 y luego enrosque la varilla autorroscante (B).

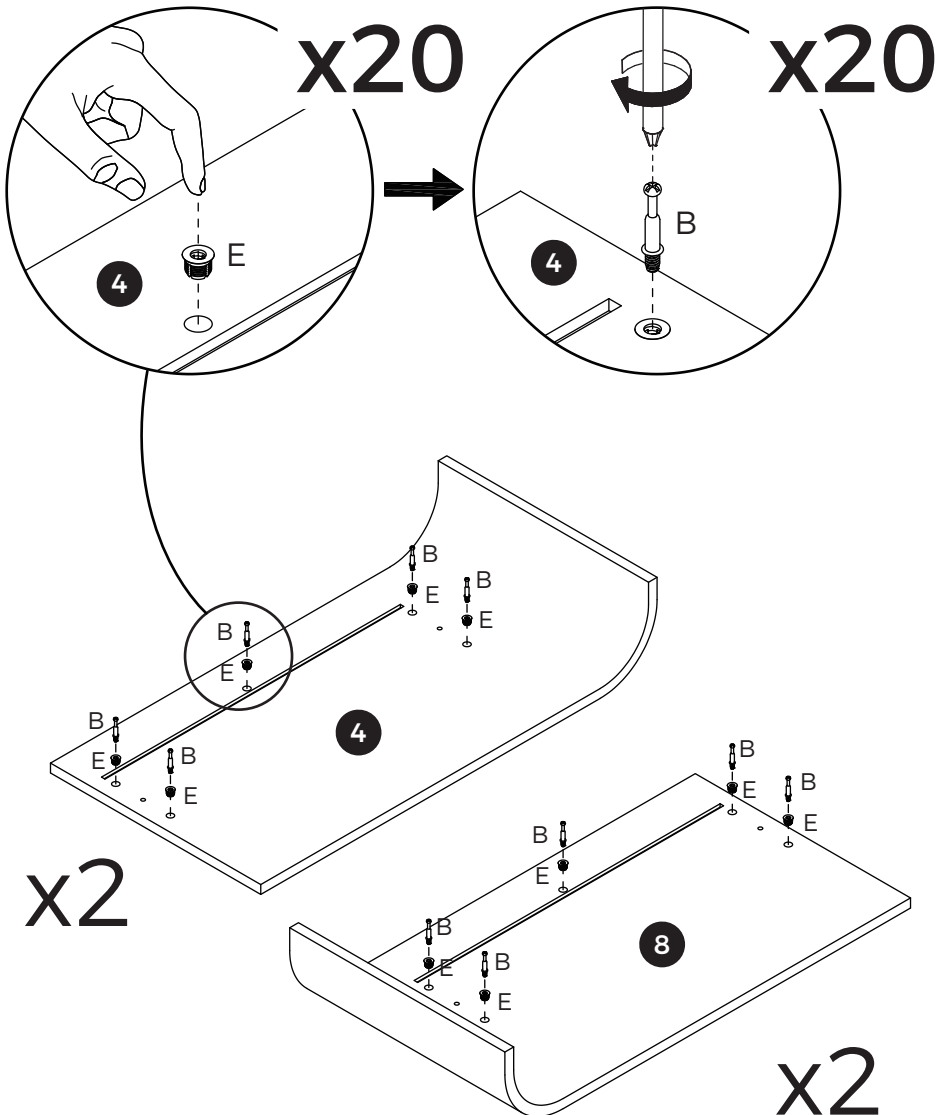

# 32



[EN] Insert wooden dowel (C) into panels 5 and 9.

[ES] Inserte el espigo de madera (C) en los paneles 5 y 9.

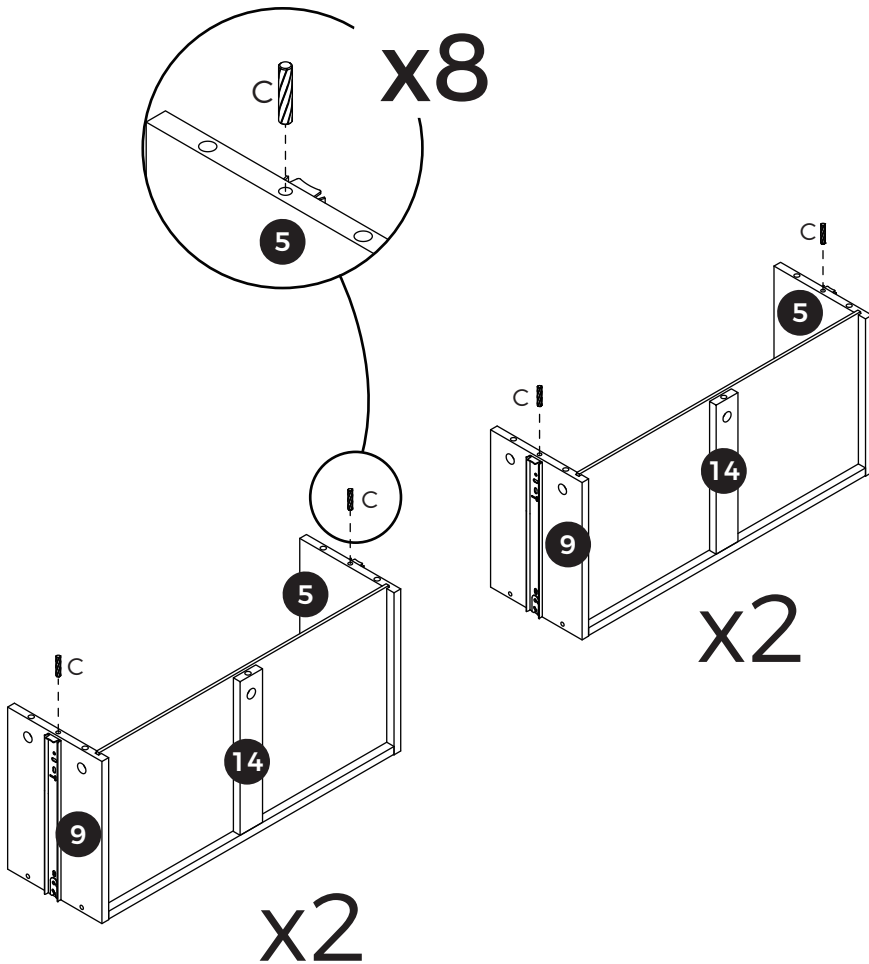

# 33



[EN] Connect panels 8 and 4 to panels 5, 14, and 9 respectively, and tighten the eccentric wheel (A) clockwise as shown.

[ES] Conecte los paneles 8 y 4 a los paneles 5, 14 y 9 respectivamente, y apriete la rueda excéntrica (A) en el sentido de las agujas del reloj, como se muestra.

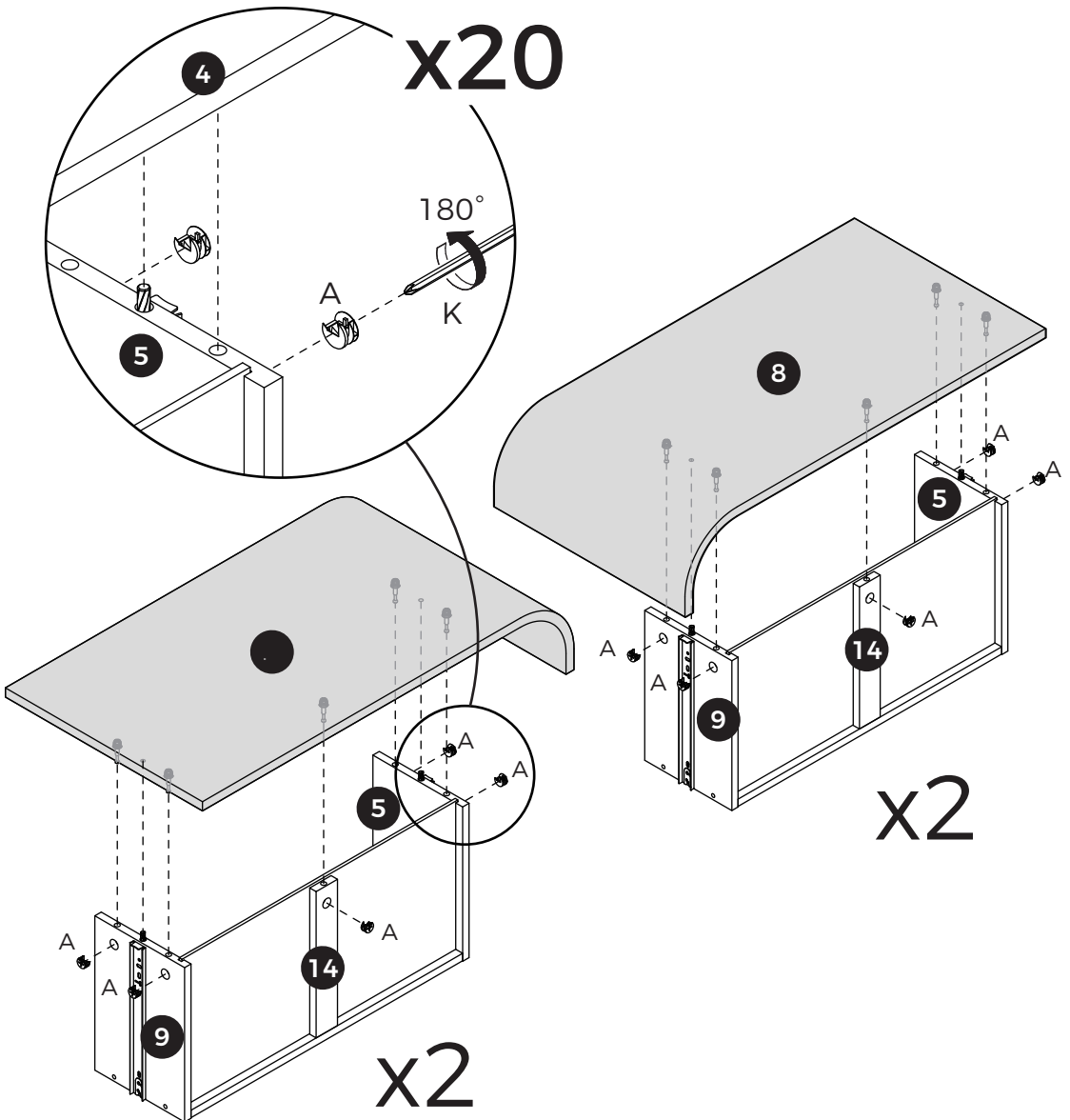

# 34

[EN] Align the drawer slides and push drawers into the cabinet.

[ES] Alinee las guías del cajón y empuje los cajones dentro del gabinete.

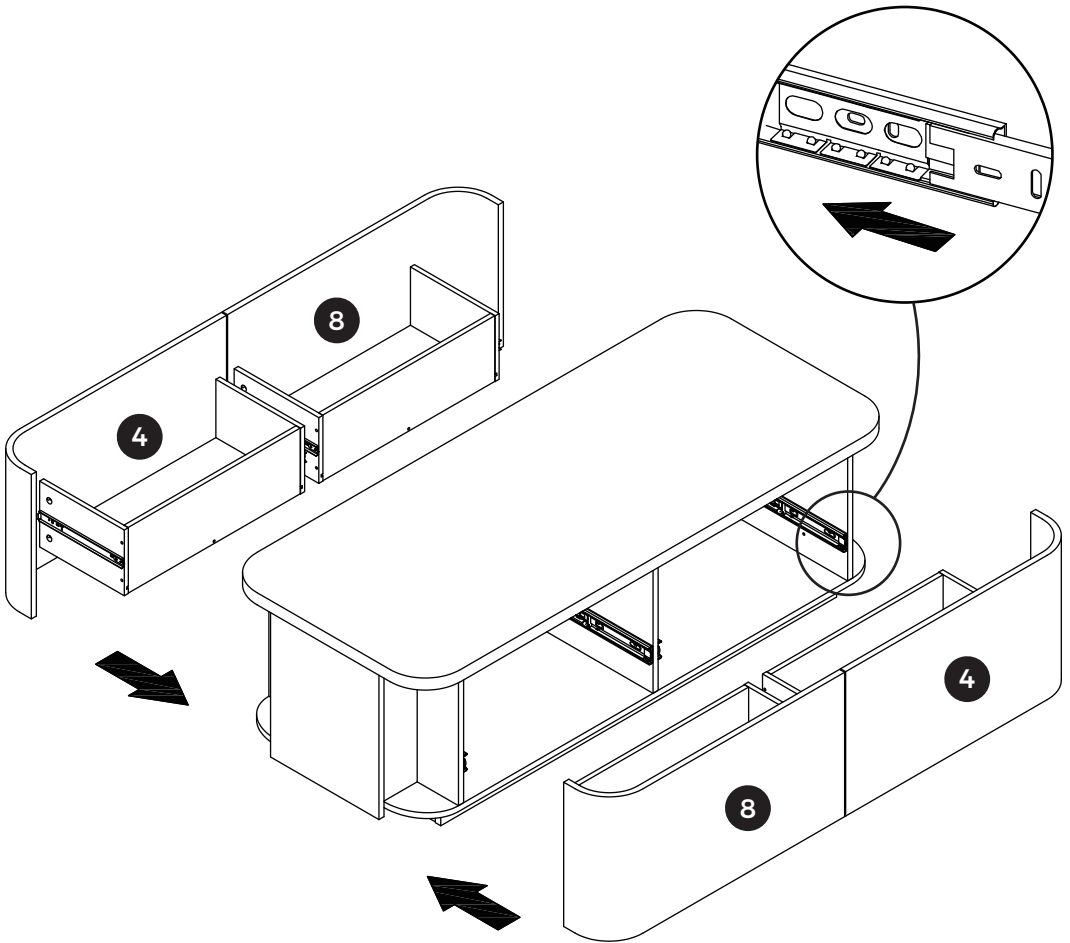



Should you have any problems assembling your product, contact us at **customerservice@homsee.com**. We're always happy to help! We have carefully selected the materials used in this product, and ask you to treat it responsibly too. Please recycle all packaging according to your local disposal rules.

Si tienes algún problema al ensamblar tu producto, contáctanos a **customerservice@homsee.com**. Siempre estaremos encantados de ayudarte. Hemos seleccionado cuidadosamente los materiales utilizados en este producto y te pedimos que también lo trates de manera responsable. Por favor, recicla todo el embalaje de acuerdo con las normas locales de eliminación de residuos.

