

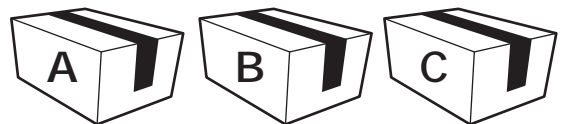

ASSEMBLY INSTRUCTIONS



DESIGN BY HOMSEE
VERSION: HS210381US-AA-001

 This product comes in 3 packages



One of the unique features of Homsee furniture is its versatility. Designed with the idea of customization in mind, our products can be easily linked together to create seamless, personalized setups that fit your specific needs.

For instance, if you purchase a couple of our shelves, you can effortlessly combine them to form a larger, unified structure. This modular approach allows you to expand, rearrange, and adapt your furniture as your space and style evolve. Whether you're looking to create a vast shelving system, or a continuous storage solution, the possibilities are endless.

At Homsee, we empower you to create a space that is truly yours—one that grows with you, all while maintaining a sleek, cohesive look.



Una de las características distintivas del mobiliario Homsee es su versatilidad. Diseñados pensando en la personalización, nuestros productos pueden conectarse fácilmente entre sí para crear configuraciones continuas y personalizadas que se ajusten a tus necesidades específicas.

Por ejemplo, si compras un par de nuestras estanterías, puedes combinarlas sin esfuerzo para formar una estructura más grande y unificada. Este enfoque modular te permite ampliar, reorganizar y adaptar tus muebles a medida que evolucionan tu espacio y tu estilo. Ya sea que busques crear un amplio sistema de estanterías o una solución de almacenamiento continua, las posibilidades son infinitas.

En Homsee, te ayudamos a crear un espacio verdaderamente tuyo—uno que crece contigo, manteniendo a la vez un aspecto elegante y coherente.

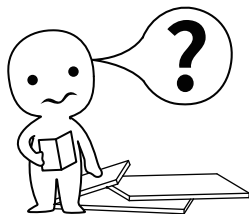

IMPORTANT INFORMATION!

Please read the entire manual before starting to assembling or using this product. Follow the manual thoroughly and keep it for further reference.

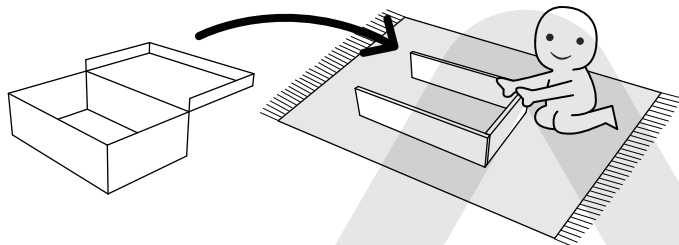

AVOID SCRATCHES!

In order to avoid scratching the furniture should be assembled on a soft layer—could be a rug.

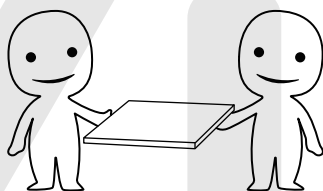

IMPROVE ASSEMBLY EFFICIENCY !

Try to find a partner to install with you, which can speed up the installation efficiency and shorten the time.

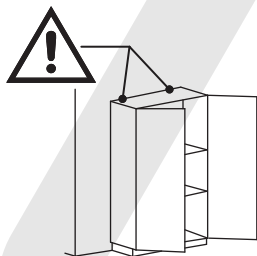

ANTI-TOPPLE WARNING !

Overturned furniture can cause serious or fatal crush injuries. To prevent tipping, be sure to use a wall-anchoring attachment. If one is not included with this product, please purchase a suitable attachment that fits your wall. If unsure, seek professional advice. Please read and follow all instructions carefully.

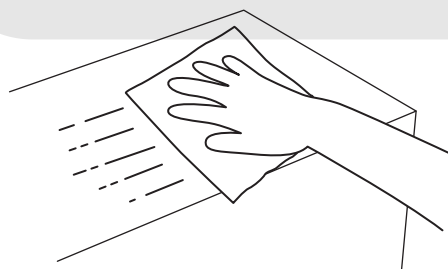

MAINTENANCE AND CLEANING !

For regular maintenance and cleaning, use a rag dipped in neutral detergent to wipe the frame thoroughly, and then dry it with a clean rag. For glass surfaces, wipe with a rag dampened with water or glass cleaner, and then dry with a clean, dry cloth.



¡INFORMACIÓN IMPORTANTE!

Por favor, lee todo el manual antes de comenzar a ensamblar o usar este producto. Sigue las instrucciones detenidamente y consérvalo para futuras consultas.

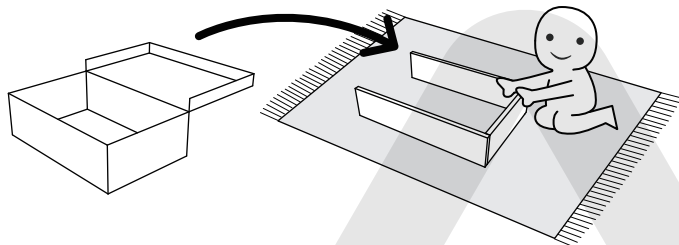

¡EVITA LOS RAYONES!

Para evitar que el mueble se raye, debe ensamblarse sobre una superficie suave, como una alfombra.

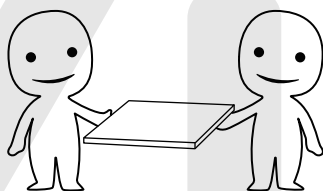

¡MEJORA LA EFICIENCIA!

Intenta encontrar a alguien que te ayude con la instalación; trabajar en pareja puede aumentar la eficiencia y reducir el tiempo de montaje.

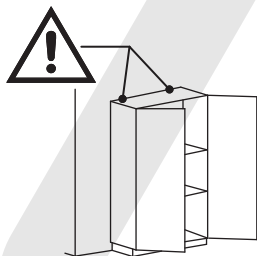

¡ADVERTENCIA ANTIVUELCO!

El mobiliario volcado puede causar lesiones graves o incluso mortales por aplastamiento. Para evitar que se vuelque, asegúrate de utilizar el sistema de anclaje a la pared. Si este producto no lo incluye, adquiere un anclaje compatible con tu pared. Si no estás seguro de cuál usar, busca asesoramiento profesional. Lee y sigue cuidadosamente cada paso de las instrucciones.

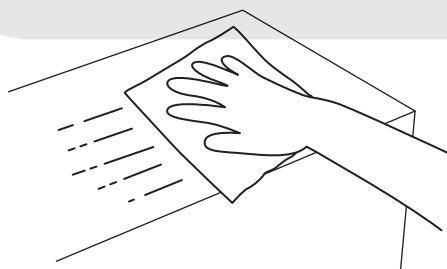

¡MANTENIMIENTO Y LIMPIEZA!

Para el mantenimiento y la limpieza regulares del producto, limpia el marco con un paño humedecido en un detergente neutro y luego sécalo con un paño limpio. Para los materiales de vidrio, límpialos con un paño humedecido en limpiador de vidrios con agua y luego sécalos con un paño seco.



The following are common installation steps. Correct operation is required to avoid product damage.

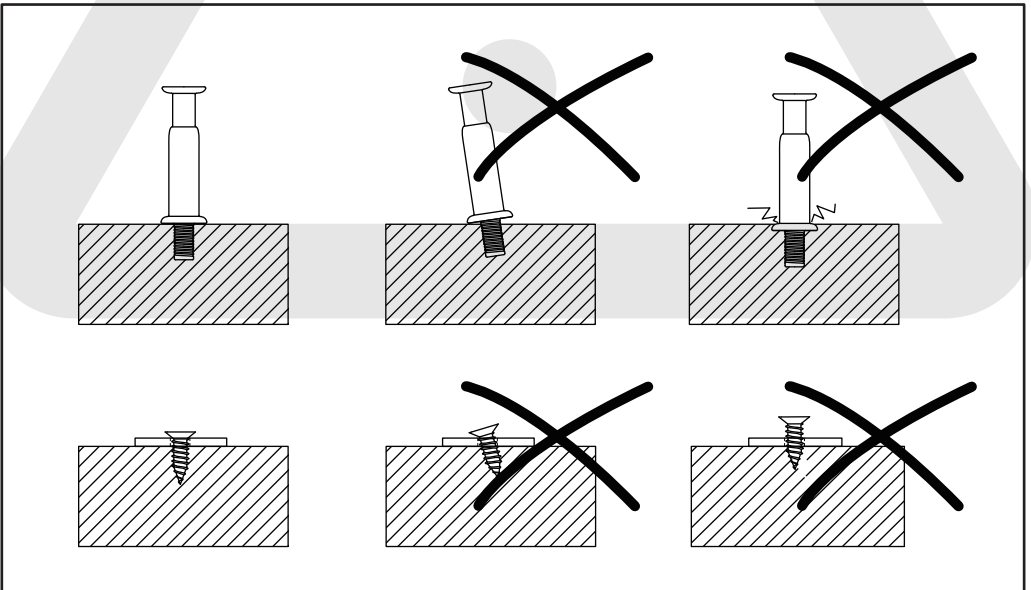
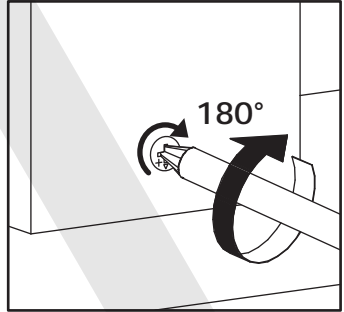
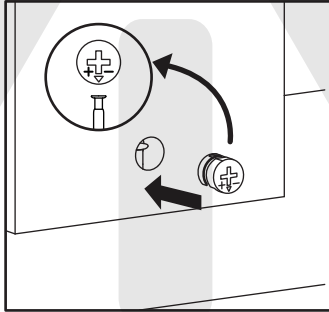
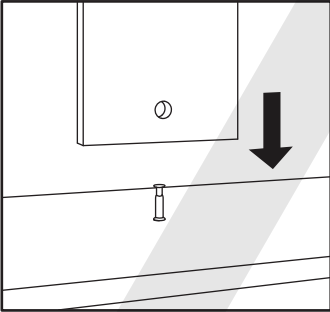
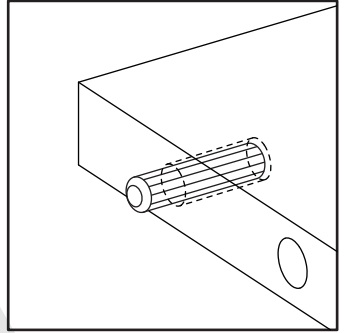
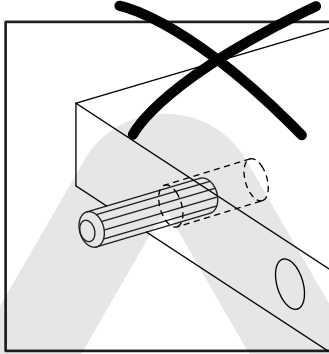
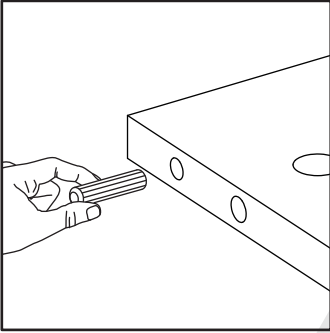



Los siguientes pasos de instalación son bastante comunes y requieren una operación correcta durante el proceso de montaje. El uso incorrecto puede dañar el mueble.

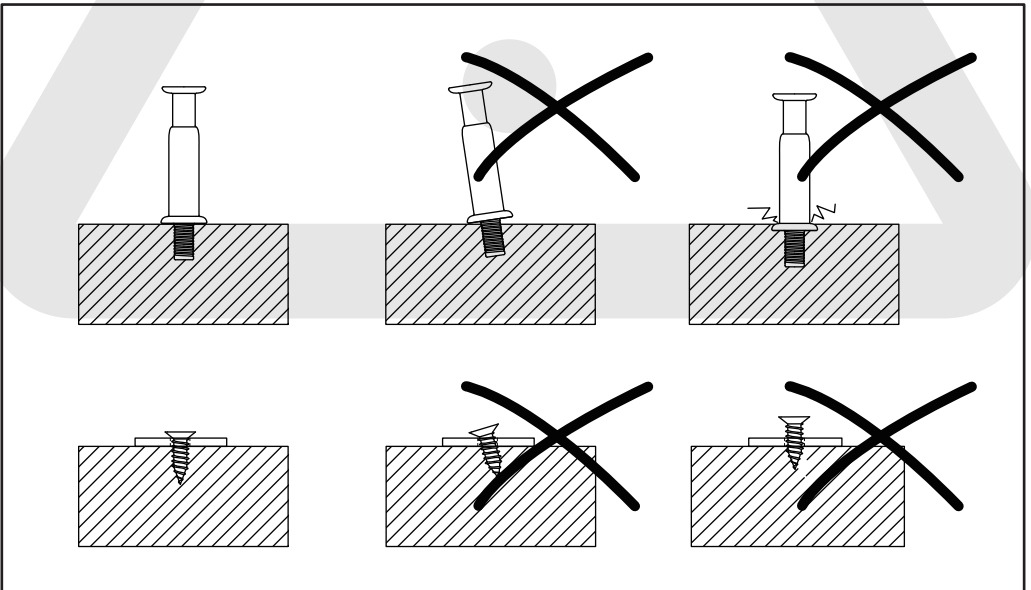
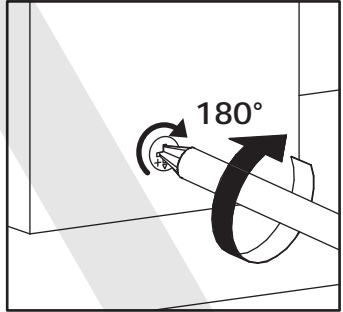
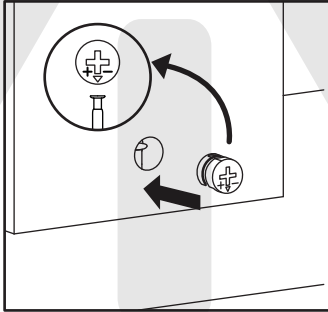
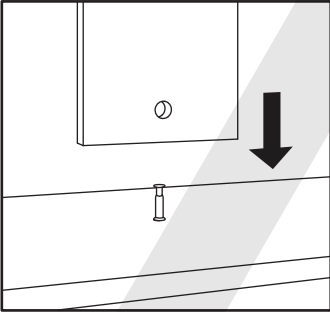
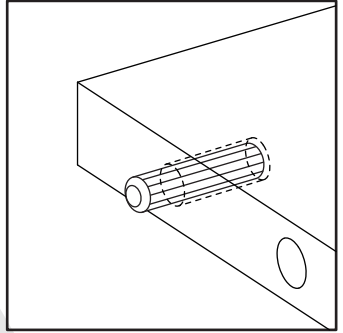
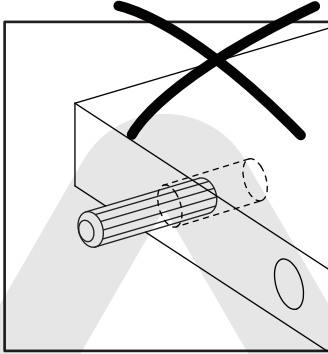
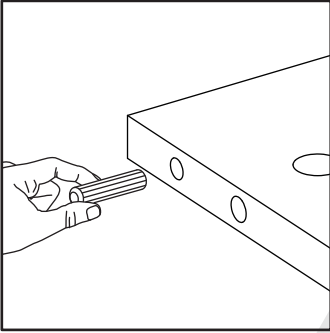



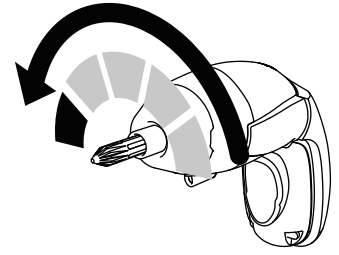
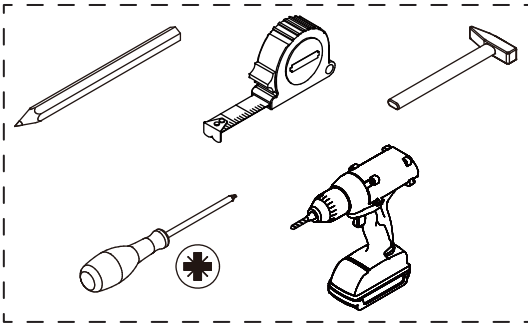











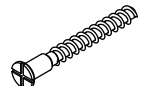
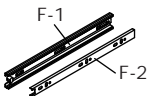

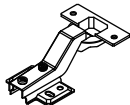
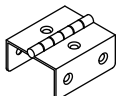
Please prepare the following tools

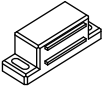

If you choose to use power tools, set them to a low-power setting. Use caution—power tools may crack or damage the furniture and can also harm the hardware.

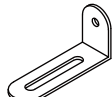

Some accessories have similar shapes, please distinguish them according to their numbers and sizes during installation.

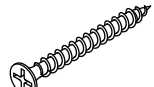
<p>A x 102</p>  <p>CRB1595A</p>	<p>B x 102</p>  <p>CRA0635B</p>	<p>C x 102</p>  <p>CRF0630A</p>	<p>D x 75</p>  <p>CRF0630A</p>	<p>E x 71</p>  <p>CRC0540A</p>
<p>F x 12</p>  <p>#3508 12</p>	<p>G x 48</p>  <p>CRD3512A</p>	<p>H x 4</p>  <p>DGA861C</p>	<p>J x 4</p>  <p>CRD3514A</p>	<p>K x 38</p>  <p>CRD3514A</p>
<p>L x 2</p> 	<p>M x 2</p> 	<p>N x 76</p>  <p>CRD0314A</p>	<p>P x 6</p> 	<p>Q x 4</p> 
<p>R x 10</p>  <p>CRE0412A</p>	<p>S x 4</p>  <p>CRE0416A</p>	<p>T x 2</p> 	<p>U x 2</p> 	<p>V x 38</p>  <p>CRD3535A</p>

W x 44



X x 2

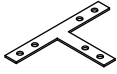

Y x 16



CRE0316A

Por favor, prepara las siguientes herramientas

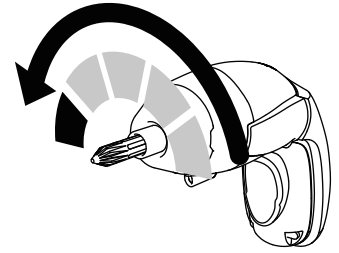
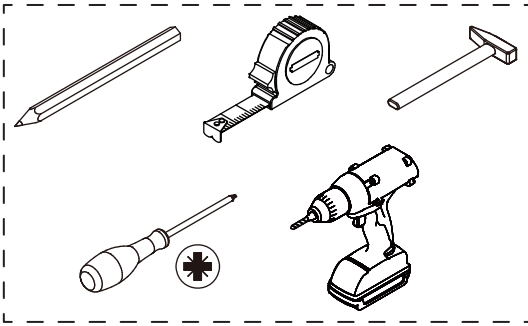

Si decides utilizar herramientas eléctricas, ajústalas a una velocidad baja. ¡Ten cuidado! Las herramientas eléctricas pueden causar grietas o daños en el mueble, y también pueden dañar los herrajes.



Algunos accesorios tienen la misma forma; por favor, distíngalos según sus números y tamaños durante la instalación.

<p>A x 102</p> <p>CRB1595A</p>	<p>B x 102</p> <p>CRA0635B</p>	<p>C x 102</p>	<p>D x 75</p> <p>CRF0630A</p>	<p>E x 71</p> <p>CRC0540A</p>
<p>F x 12</p> <p>#3508 12</p>	<p>G x 48</p> <p>CRD3512A</p>	<p>H x 4</p> <p>DGA861C</p>	<p>J x 4</p>	<p>K x 38</p> <p>CRD3514A</p>
<p>L x 2</p>	<p>M x 2</p>	<p>N x 76</p> <p>CRD0314A</p>	<p>P x 6</p>	<p>Q x 4</p>
<p>R x 10</p> <p>CRE0412A</p>	<p>S x 4</p> <p>CRE0416A</p>	<p>T x 2</p>	<p>U x 2</p>	<p>V x 38</p> <p>CRD3535A</p>

W x 44



X x 2

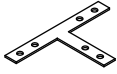

Y x 16



CRE0316A

Parts List

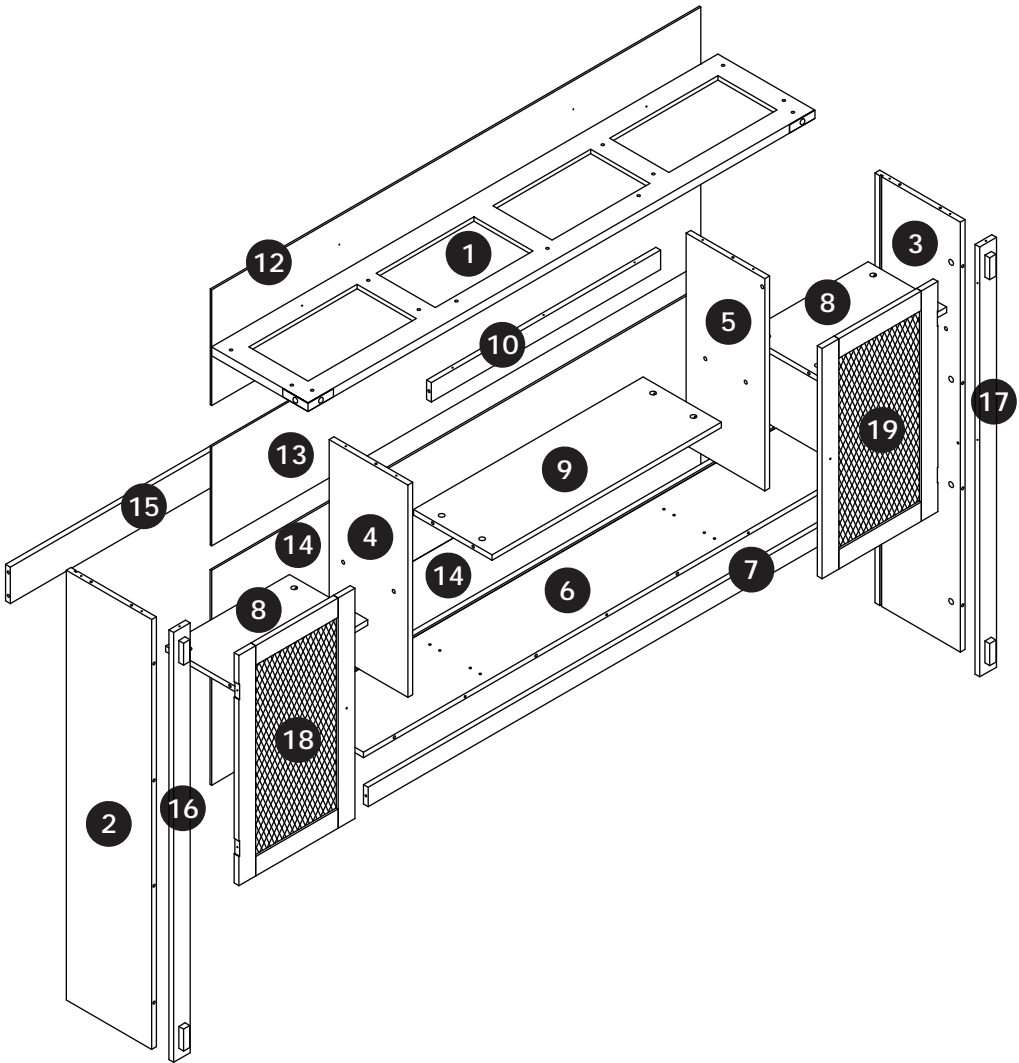

⚠ WARNING	
	<p>Children have died from furniture tipover. To reduce the risk of furniture tipover:</p> <ul style="list-style-type: none"> • ALWAYS install Anti-tip device provided • NEVER put a TV on this product. • NEVER allow children to stand, climb or hang on drawers, doors, or shelves. • NEVER open more than one drawer at a time. • Place heaviest items in the lowest drawers. <p style="text-align: center;">This is a permanent label. Do not remove!</p>
	



120 MINUTES



2 ADULTS



DIFFICULT

The parts listed above are required for proper assembly. If there are any issues. Contact us: customerservice@homsee.com

Parts List

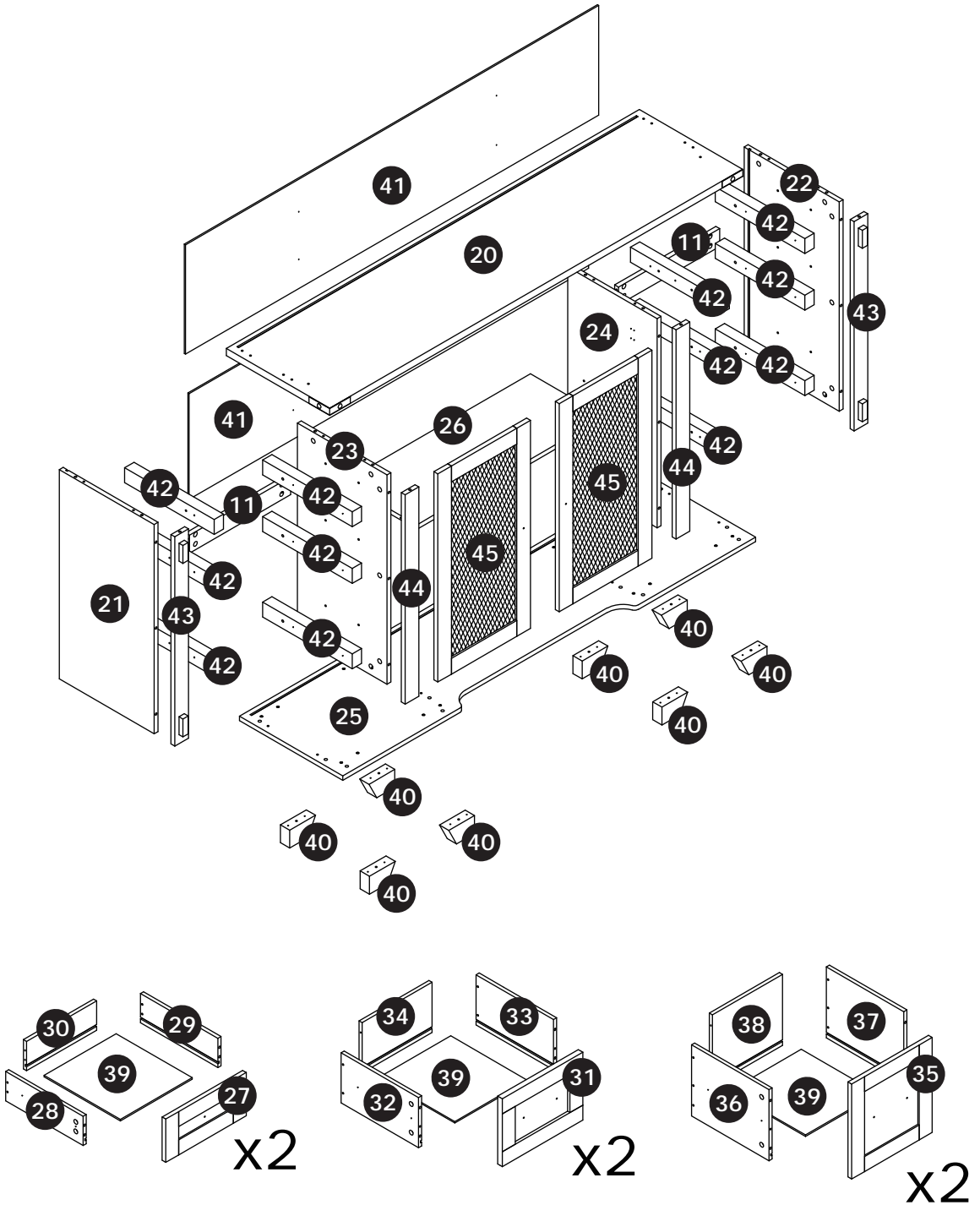

Lista de Piezas

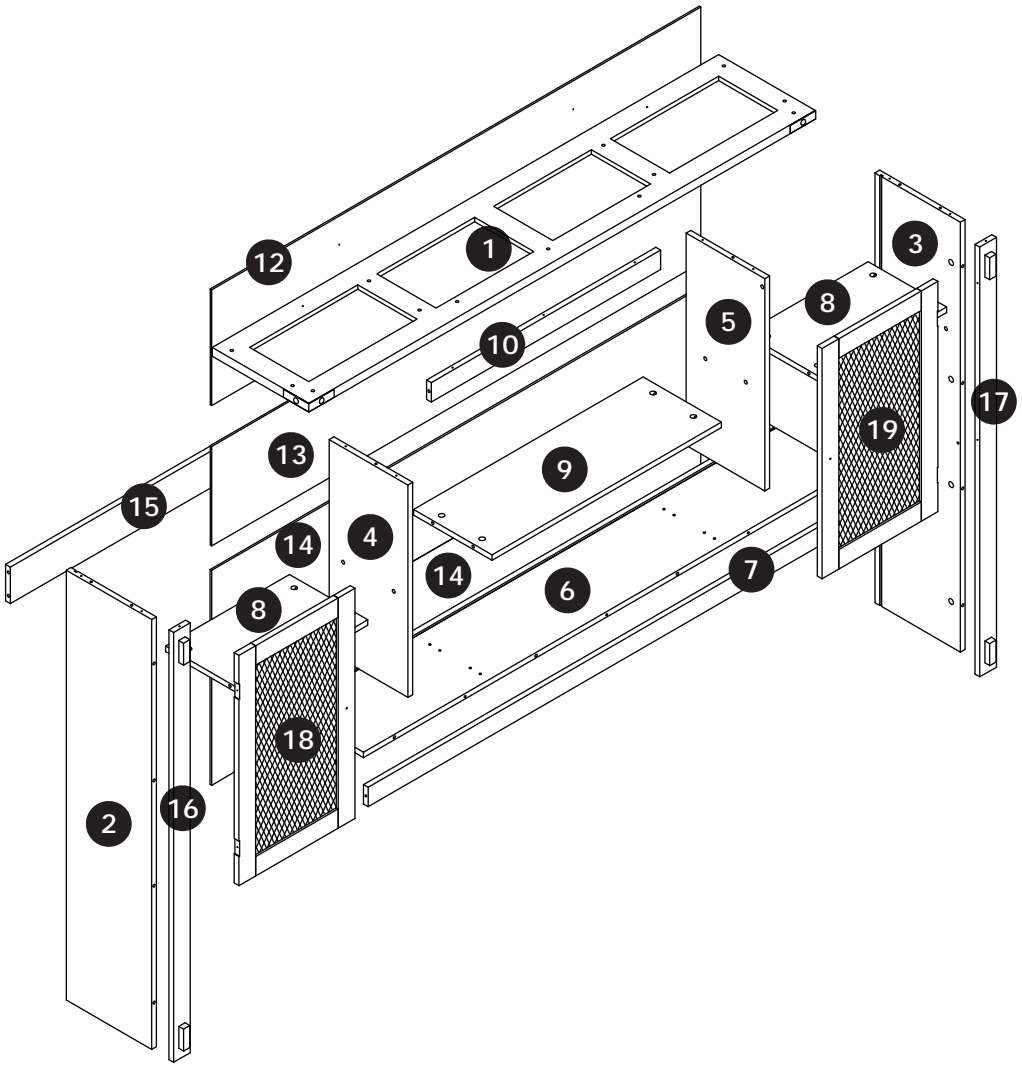

⚠ ADVERTENCIA

Los niños han muerto por el vuelco de muebles. Para reducir el riesgo de que el mueble se vuelque:

- SIEMPRE instala el dispositivo antivuelco incluido.
- NUNCA coloques un televisor sobre este producto.
- NUNCA permitas que los niños se suban, trepen o cuelguen de los cajones, puertas o estantes.
- NUNCA abras más de un cajón a la vez.
- Coloca los objetos más pesados en los cajones inferiores.

Esta es una etiqueta permanente. ¡No la retires!



120 MINUTOS



2 ADULTOS



DIFÍCIL

Las piezas enumeradas arriba son necesarias para un montaje correcto. Si tienes algún problema, contáctanos en: customerservice@homsee.com

Lista de Piezas

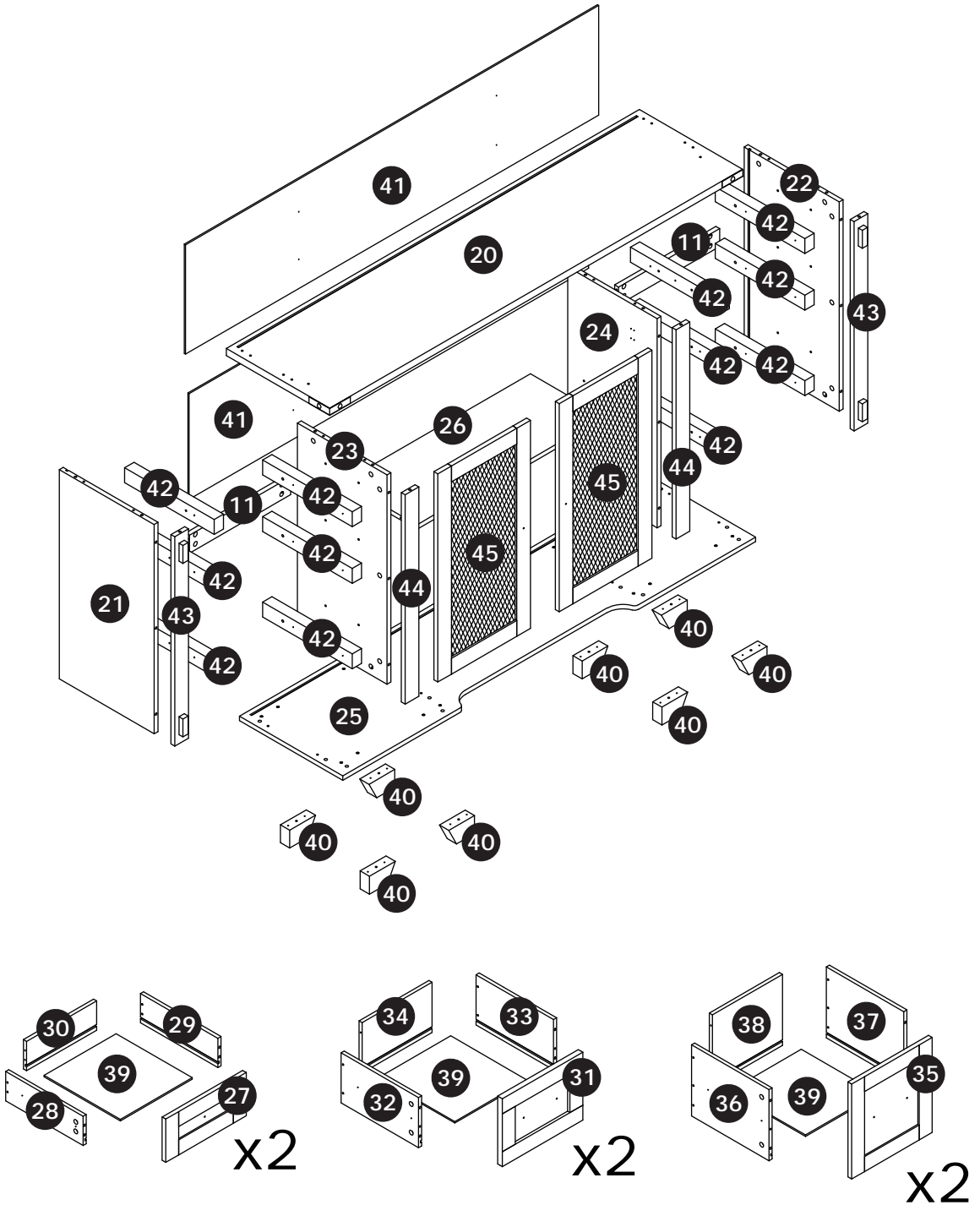



Cut out this page for easy viewing during subsequent installation.

Recorte esta página para poder consultarla fácilmente durante la instalación posterior.

Parts List

Lista de Piezas

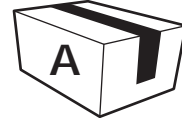

BOX 1/3
CAJA 1/3

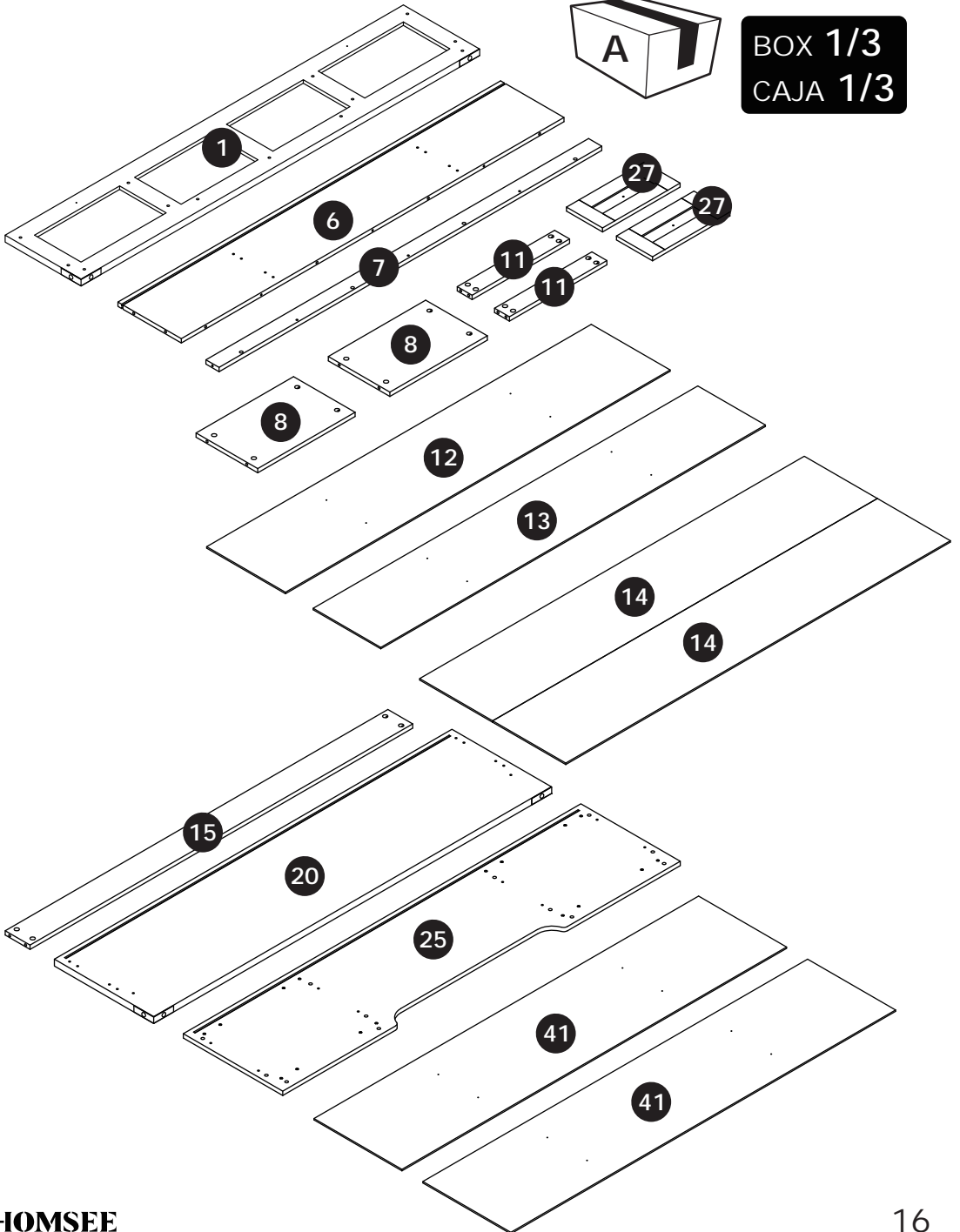

Parts List

Lista de Piezas

Cut out this page for easy viewing during subsequent installation.

Recorte esta página para poder consultarla fácilmente durante la instalación posterior.



BOX 2/3
CAJA 2/3

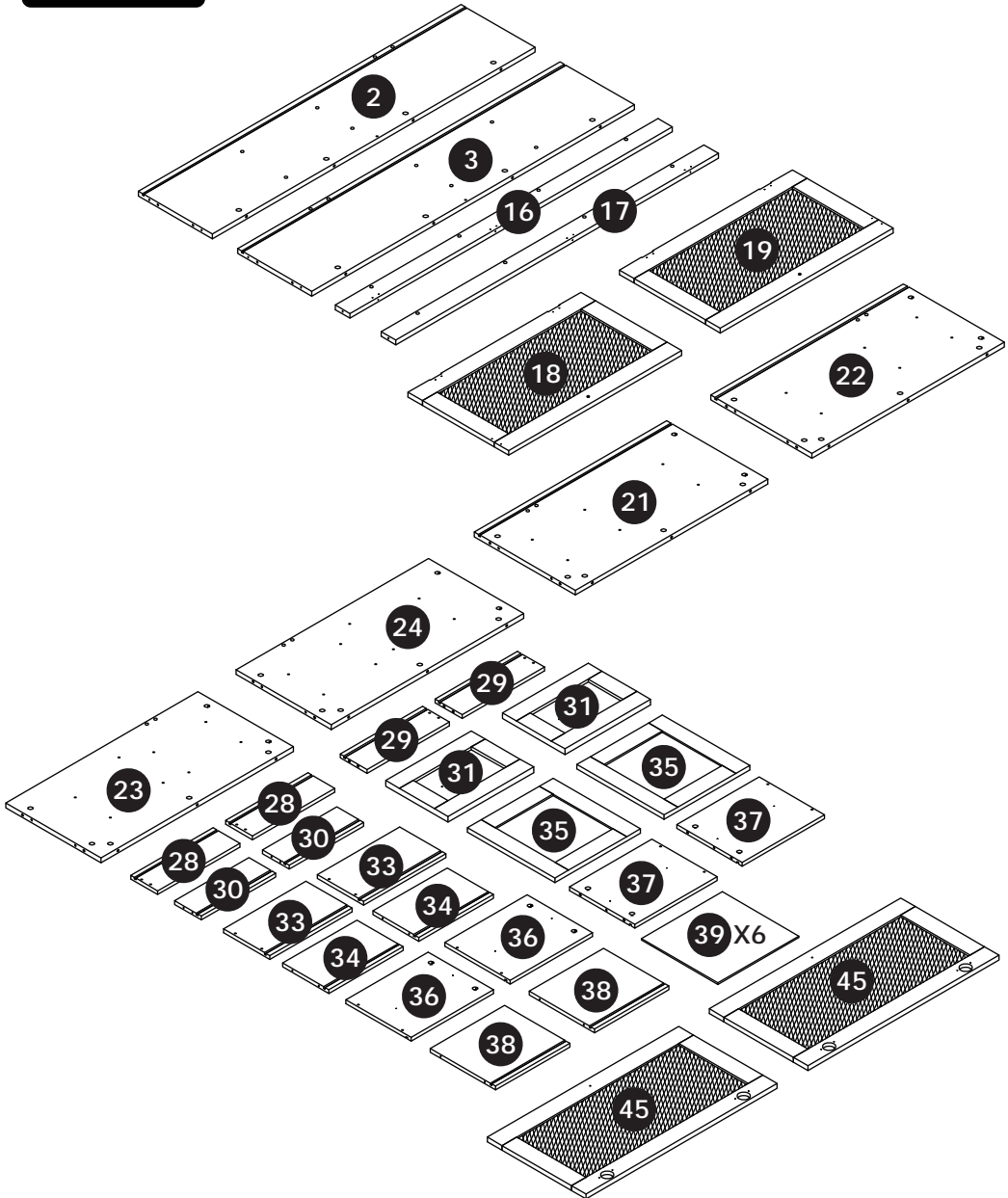
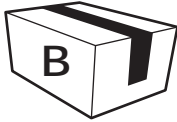



Cut out this page for easy viewing during subsequent installation.

Recorte esta página para poder consultarla fácilmente durante la instalación posterior.

Parts List

Lista de Piezas

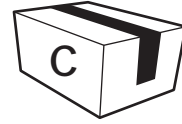

BOX 3/3
CAJA 3/3

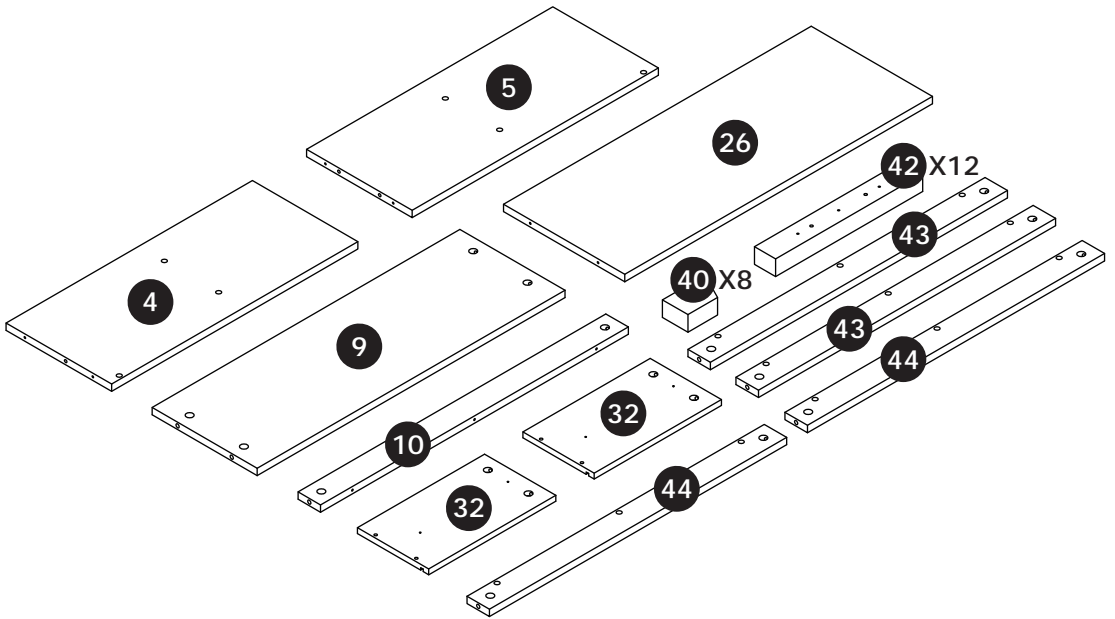

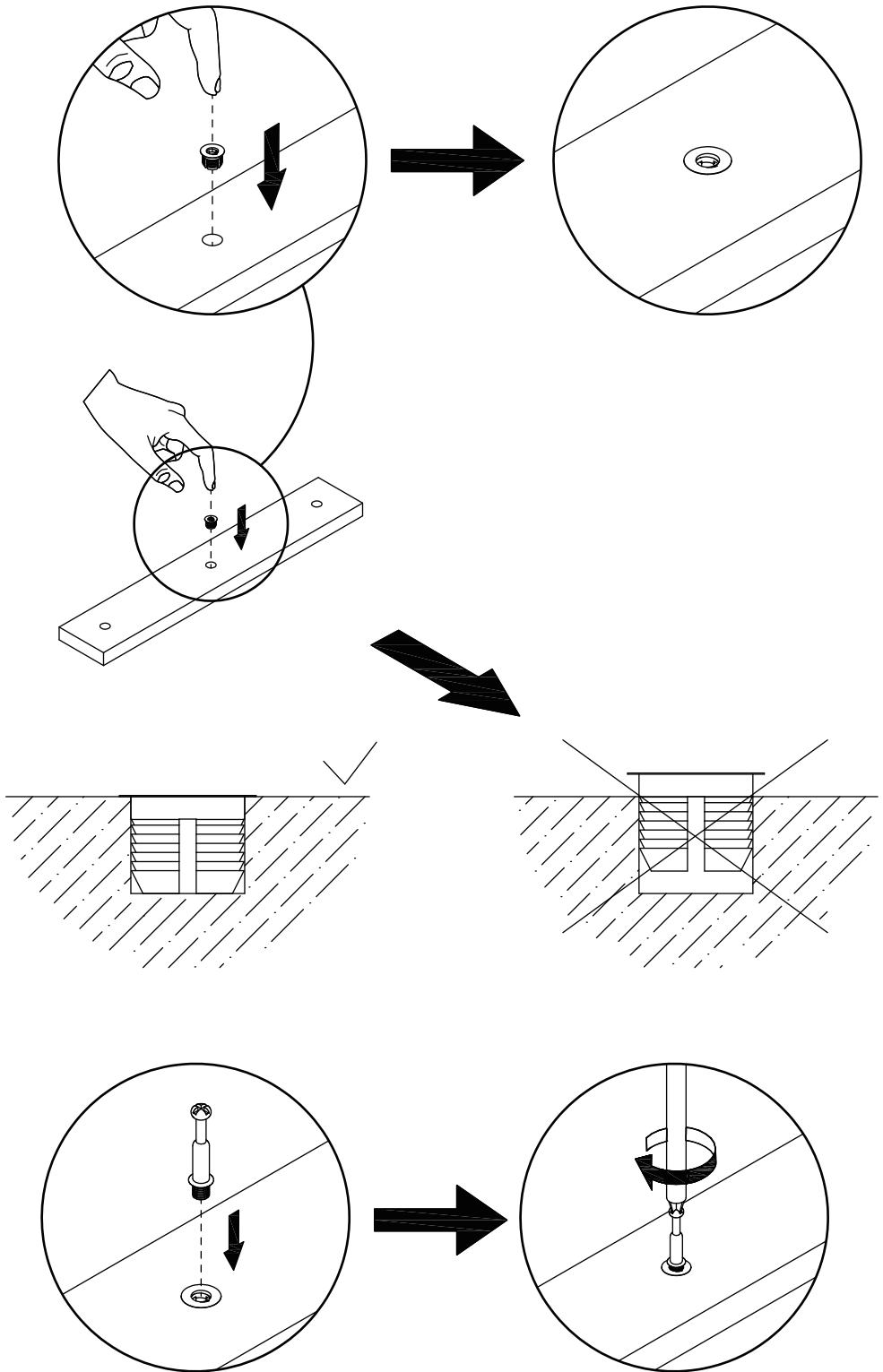

Separate glide into two parts at first.

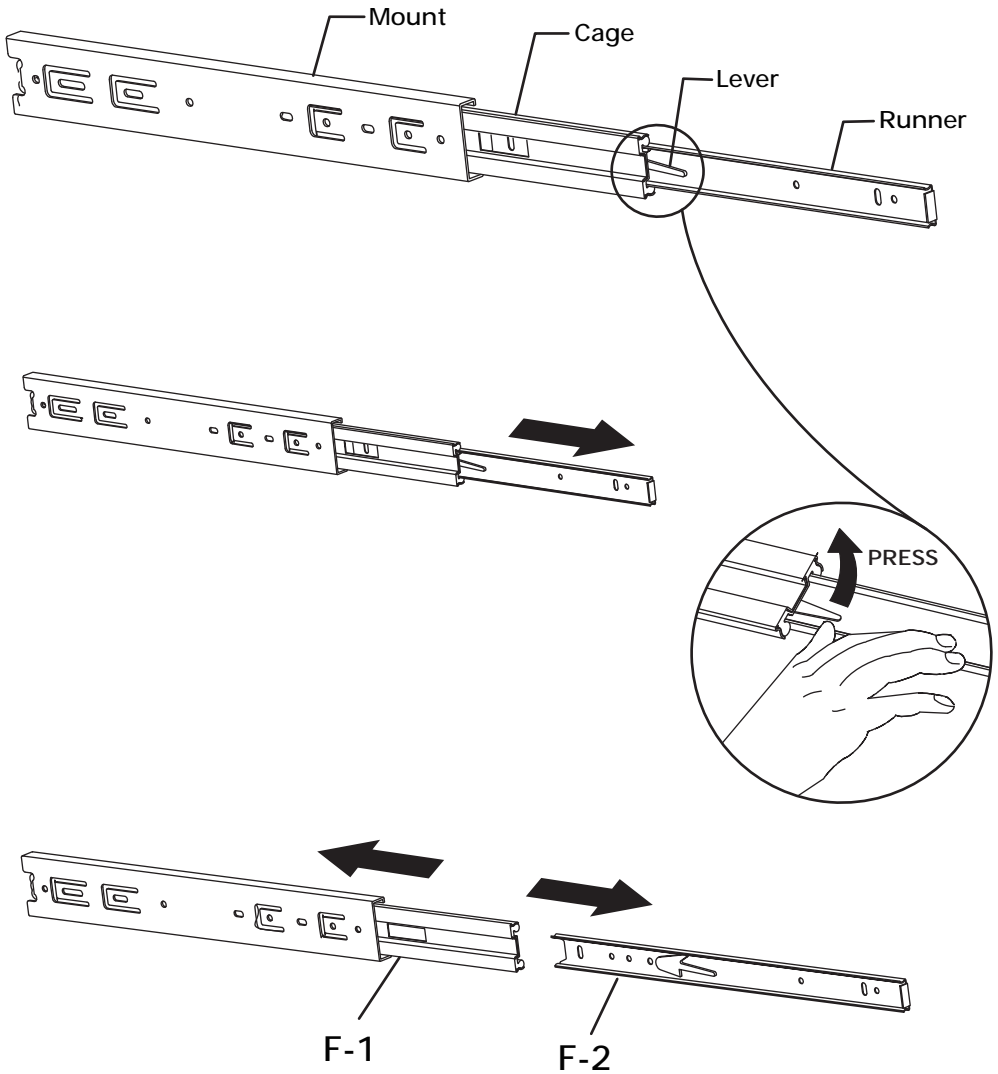

01



[EN] Attach component (C) to panel 4, then screw the self-tapping screw (B) into panel 4.

[ES] Fije el componente (C) al panel 4 y luego atornille el tornillo autorroscante (B) en el panel 4.

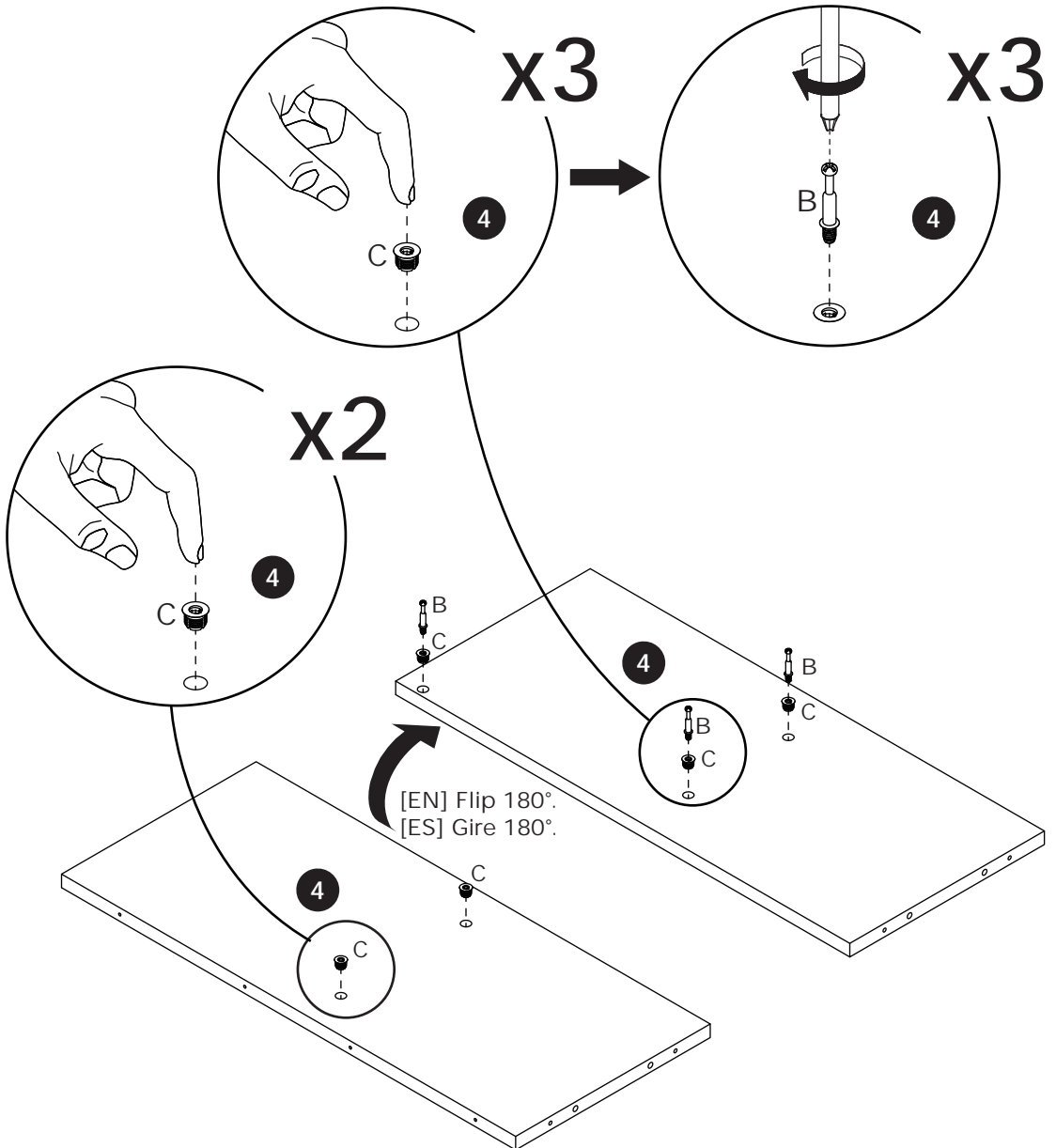

02



[EN] Attach component (C) to panel 5, then screw the self-tapping screw (B) into panel 5.

[ES] Fije el componente (C) al panel 5 y luego atornille el tornillo autorroscante (B) en el panel 5.

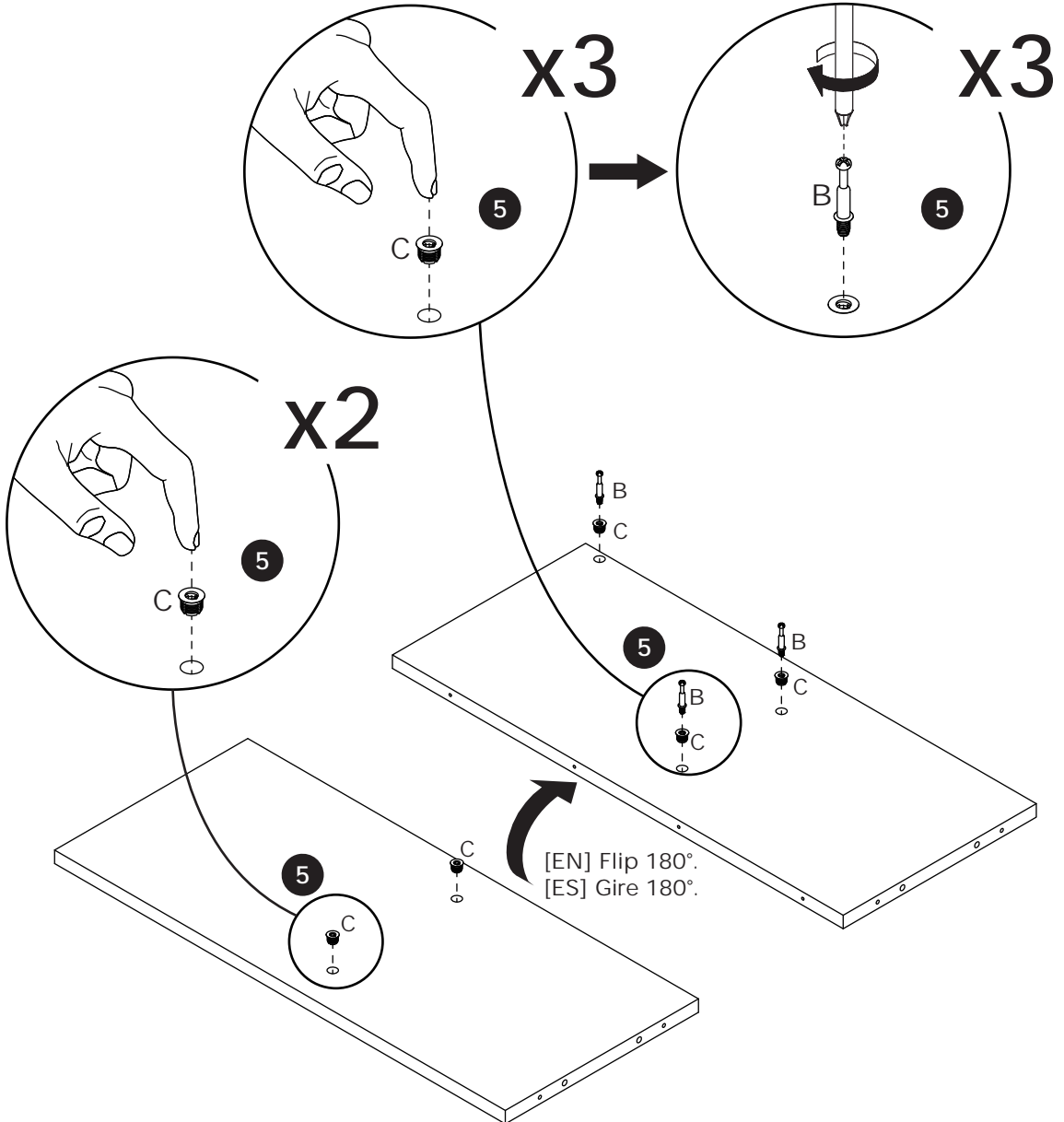

03



[EN] Attach panels 9 and 10 to panel 4, insert the eccentric cam (A), and tighten by turning clockwise.

[ES] Fije los paneles 9 y 10 al panel 4, inserte el excéntrico (A) y apriete girando en sentido horario.

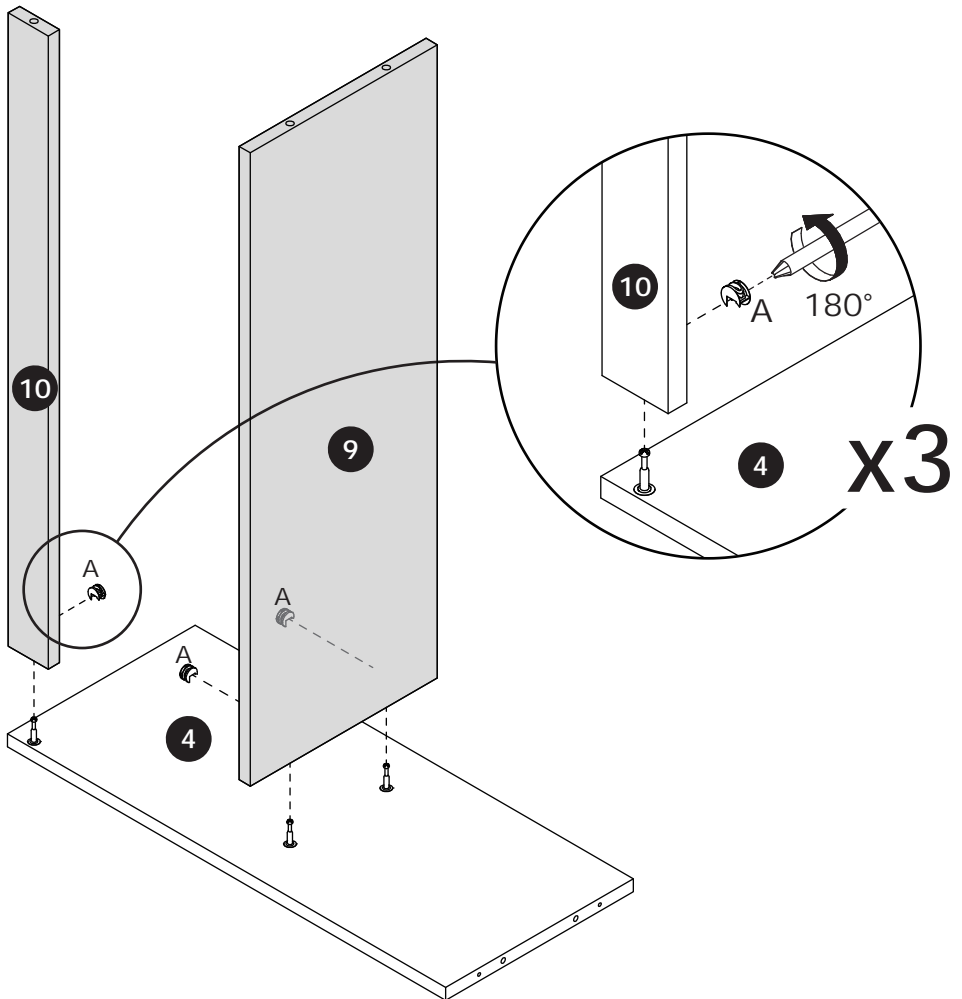

04



[EN] Attach panel 5 to panels 9 and 10, insert the eccentric cam (A), and tighten by turning clockwise.

[ES] Fije el panel 5 a los paneles 9 y 10, inserte el excéntrico (A) y apriete girando en sentido horario.

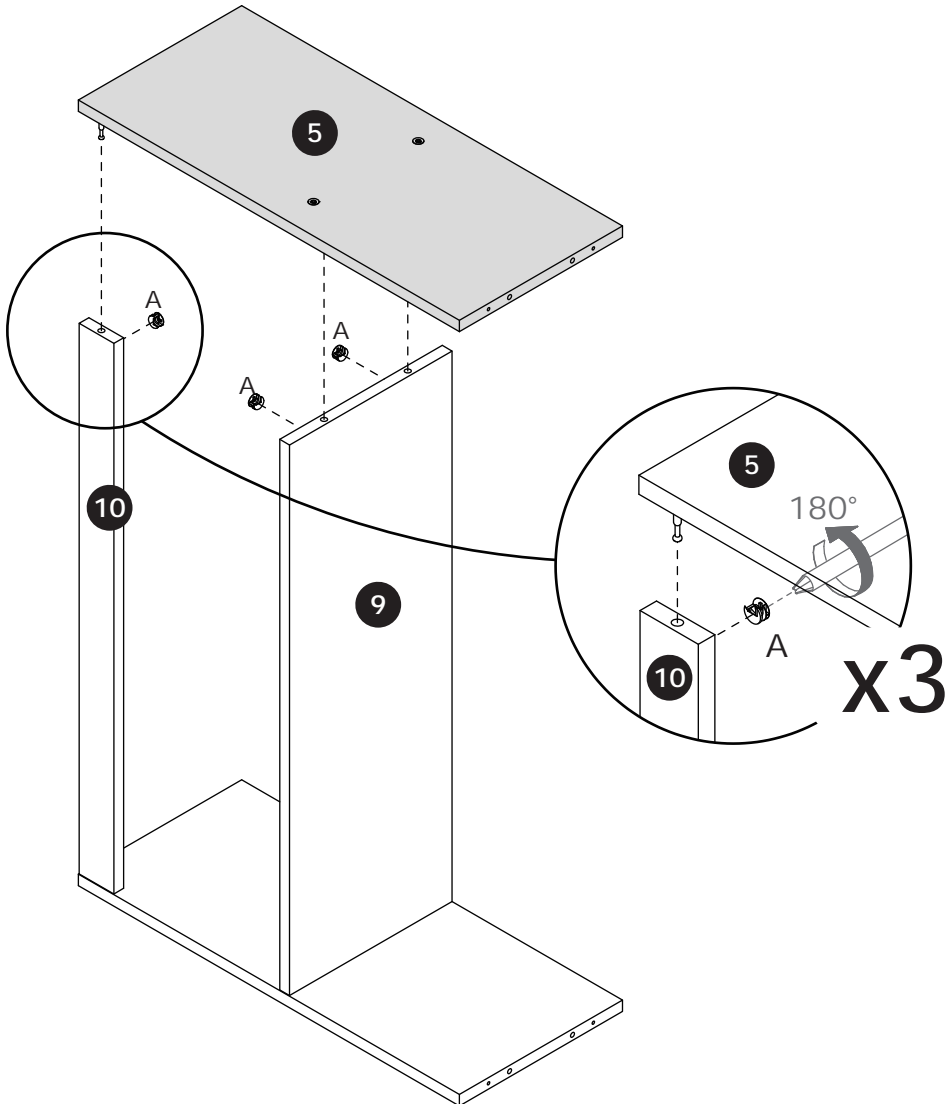

05



[EN] Attach component (C) to panel 7, then screw the self-tapping screw (B) into panel 7.

[ES] Fije el componente (C) al panel 7 y luego atornille el tornillo autorroscante (B) en el panel 7.

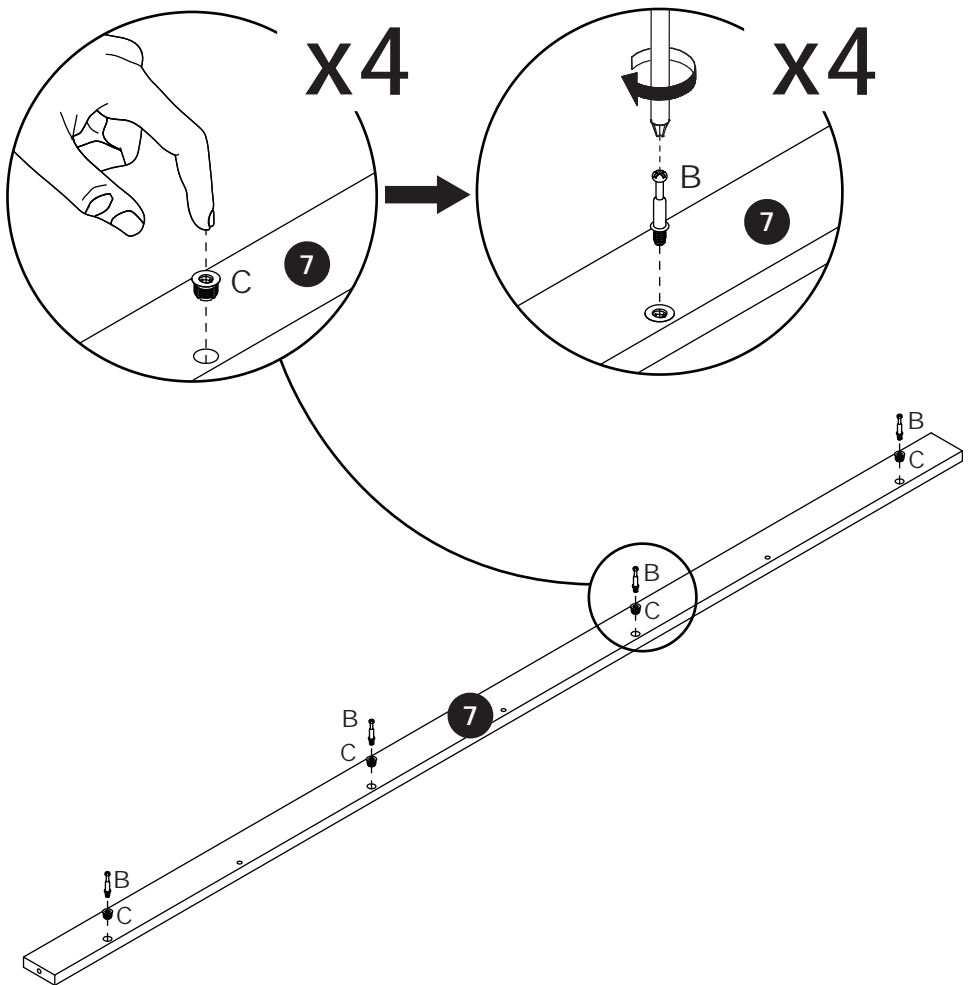

06



[EN] Attach panel 7 to panel 6 with wooden dowel (D), insert the eccentric cam (A), and tighten by turning clockwise.

[ES] Fije el panel 7 al panel 6 con la espiga de madera (D), inserte el excéntrico (A) y apriete girando en sentido horario.

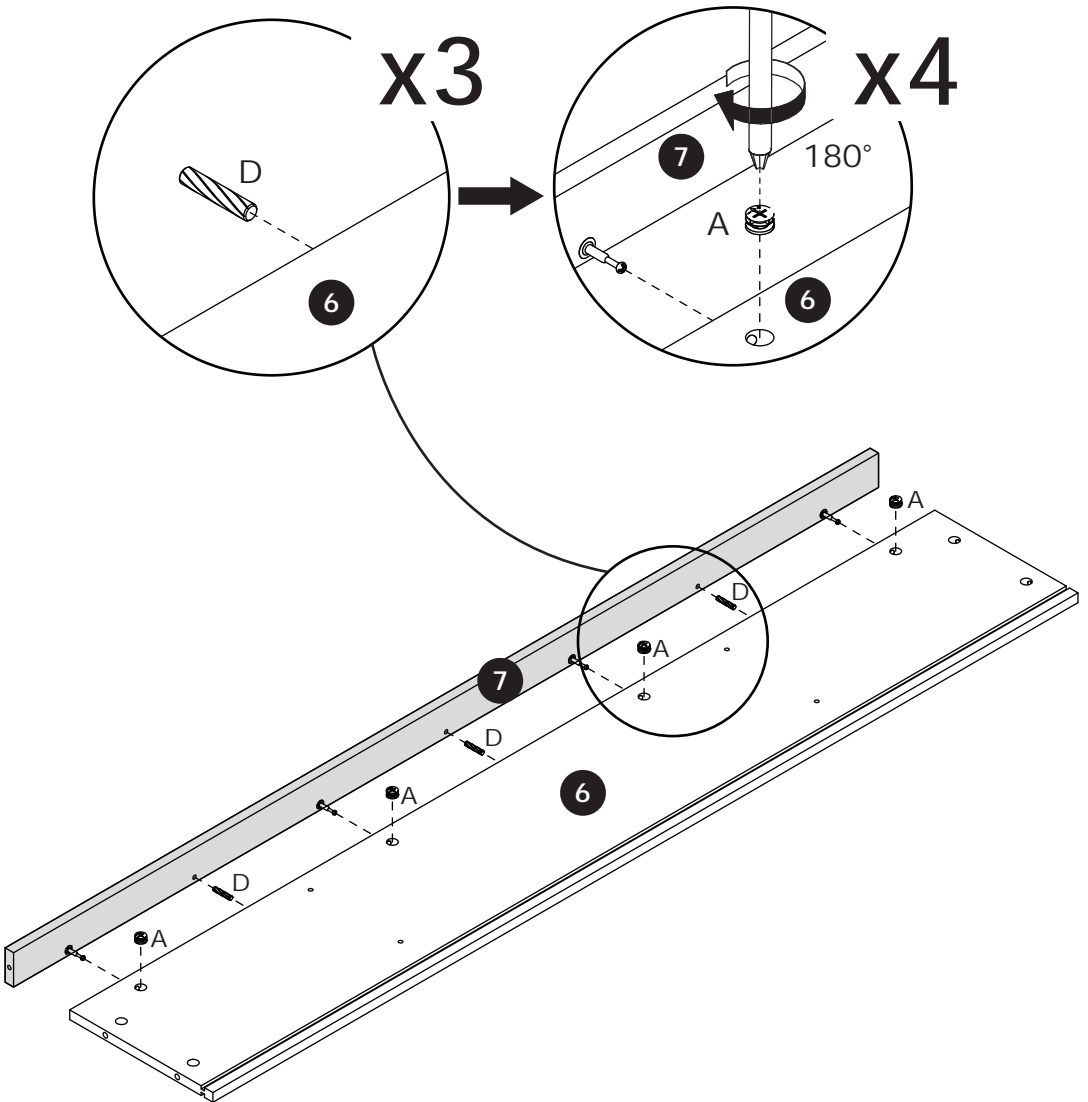

07



[EN] Attach panel 6 to panels 4 and 5 with wooden dowel (D) and secure with screws (E).

[ES] Fije el panel 6 a los paneles 4 y 5 con espigas de madera (D) y fíjelo con tornillos (E).

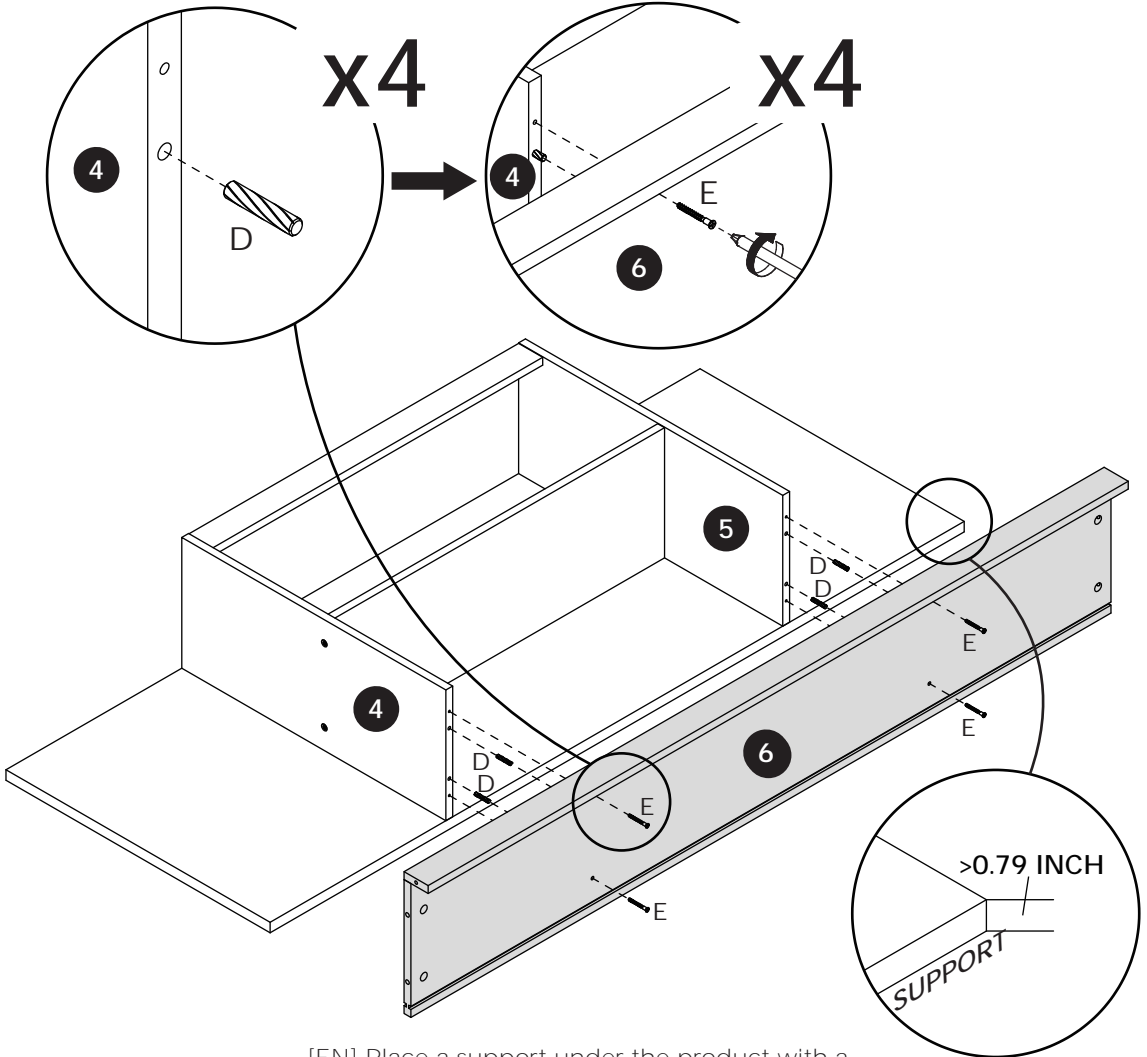

[EN] Place a support under the product with a thickness greater than 0.79 inches.

[ES] Coloque un soporte debajo del producto con un grosor superior a 0.79 pulgadas.

08



[EN] Screw the self-tapping screw (B) into panel 4 and panel 5.

[ES] Atornille el tornillo autorroscante (B) en el panel 4 y el panel 5

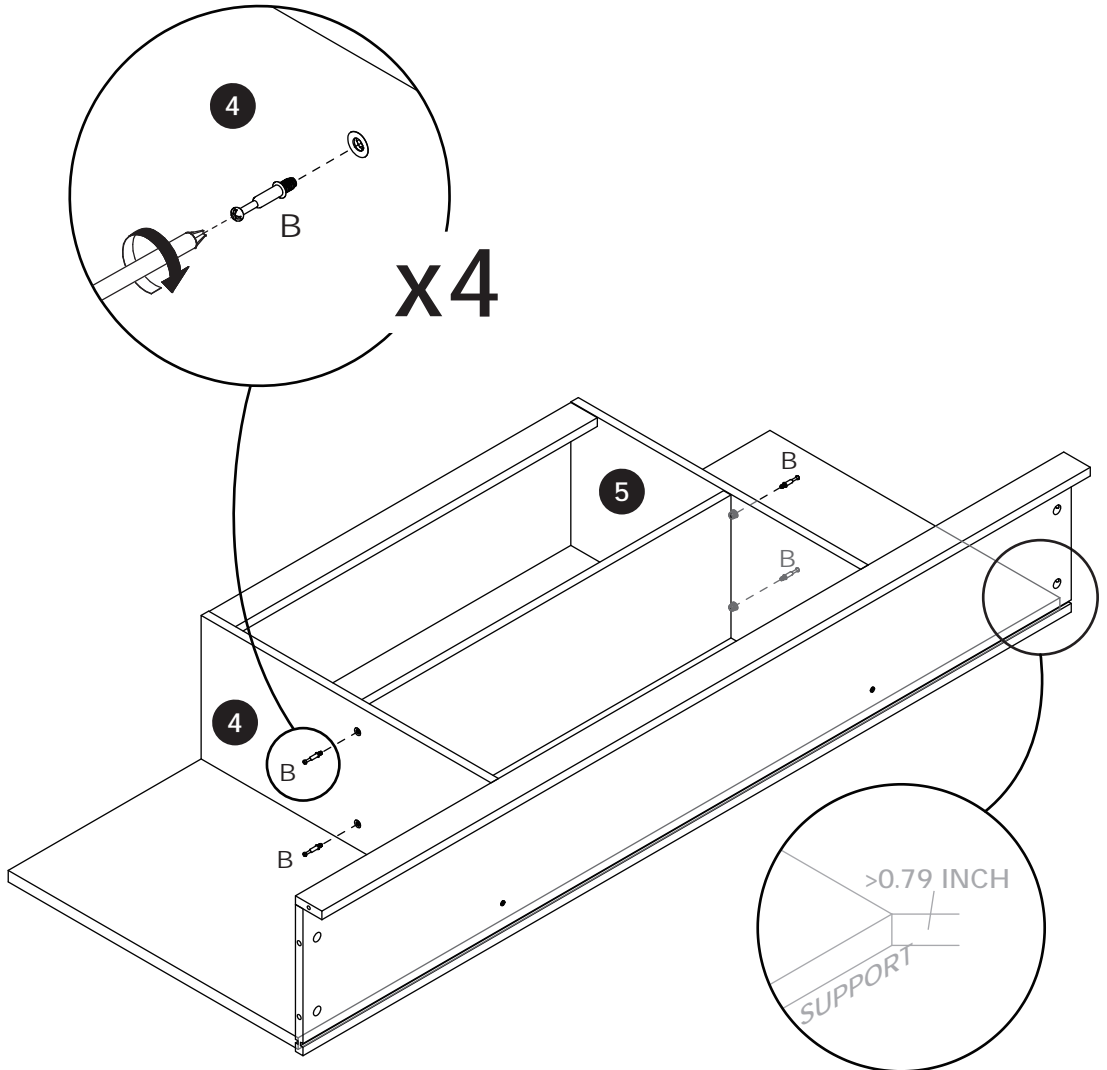

[EN] Place a support under the product with a thickness greater than 0.79 inches.

[ES] Coloque un soporte debajo del producto con un grosor superior a 0.79 pulgadas.

09



[EN] Attach panel 8 to panels 4 and 5, insert the eccentric cam (A), and tighten by turning clockwise.

[ES] Fije el panel 8 a los paneles 4 y 5, inserte el excéntrico (A) y apriete girando en sentido horario.

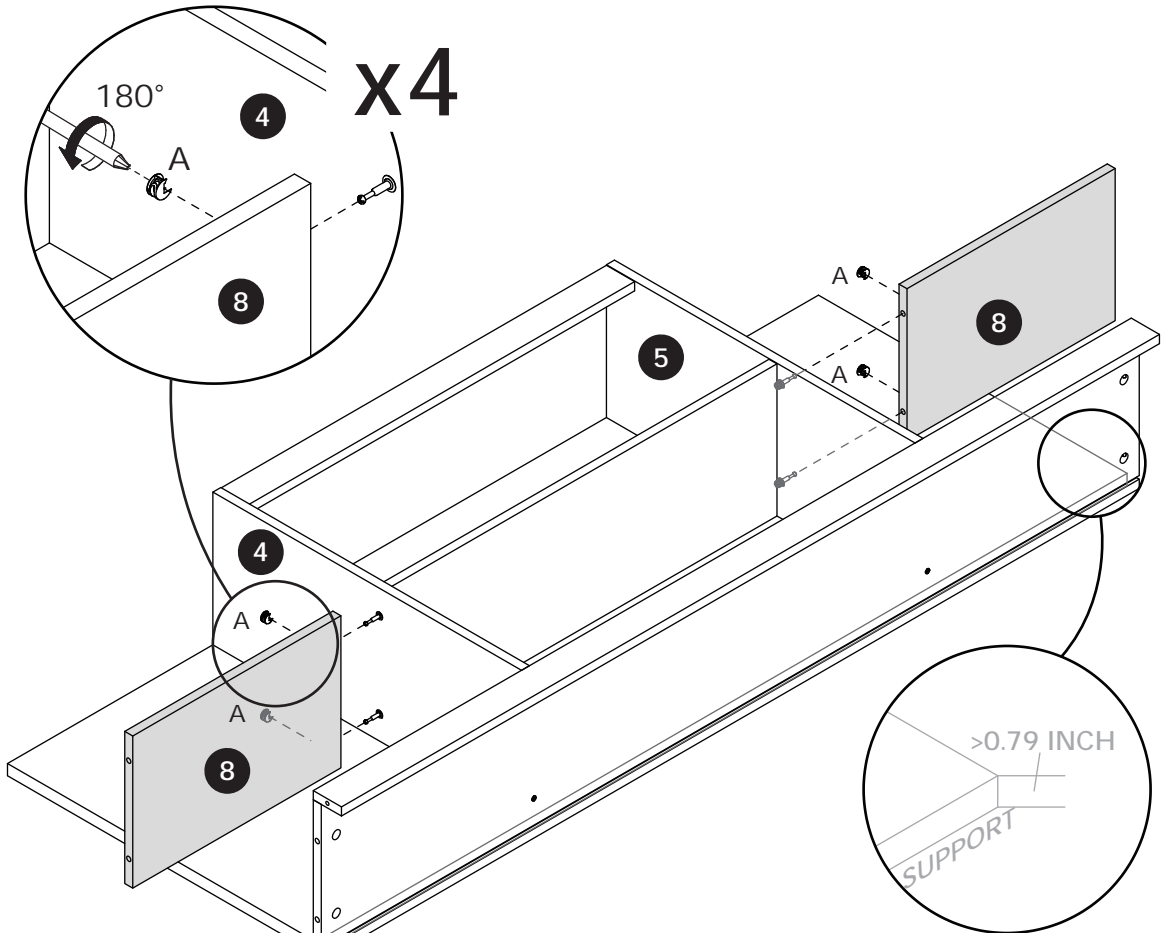

[EN] Place a support under the product with a thickness greater than 0.79 inches.

[ES] Coloque un soporte debajo del producto con un grosor superior a 0.79 pulgadas.

10



[EN] Attach component (C) to panel 2 and panel 3, then screw the self-tapping screw (B) into panel 2 and panel 3.

[ES] Fije el componente (C) al panel 2 y al panel 3, luego atornille el tornillo autorroscante (B) en el panel 2 y el panel 3.

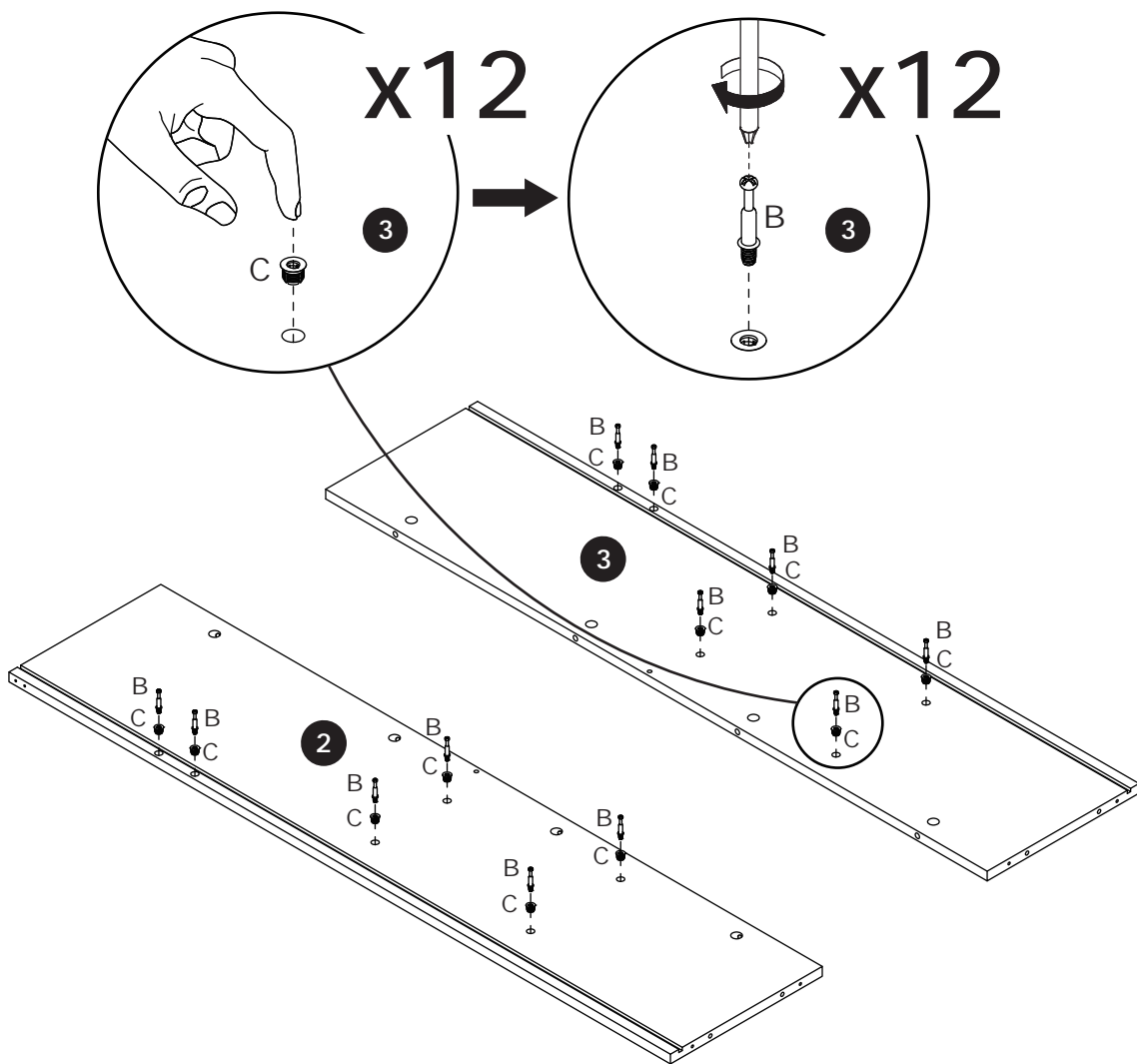

11



[EN] Attach panels 2 and 3 to panels 6, 7, 8, and 15 with wooden dowel (D), insert the eccentric cam (A), and tighten by turning clockwise.

[ES] Fije los paneles 2 y 3 a los paneles 6, 7, 8 y 15 con espigas de madera (D), inserte el excéntrico (A) y apriete girando en sentido horario.

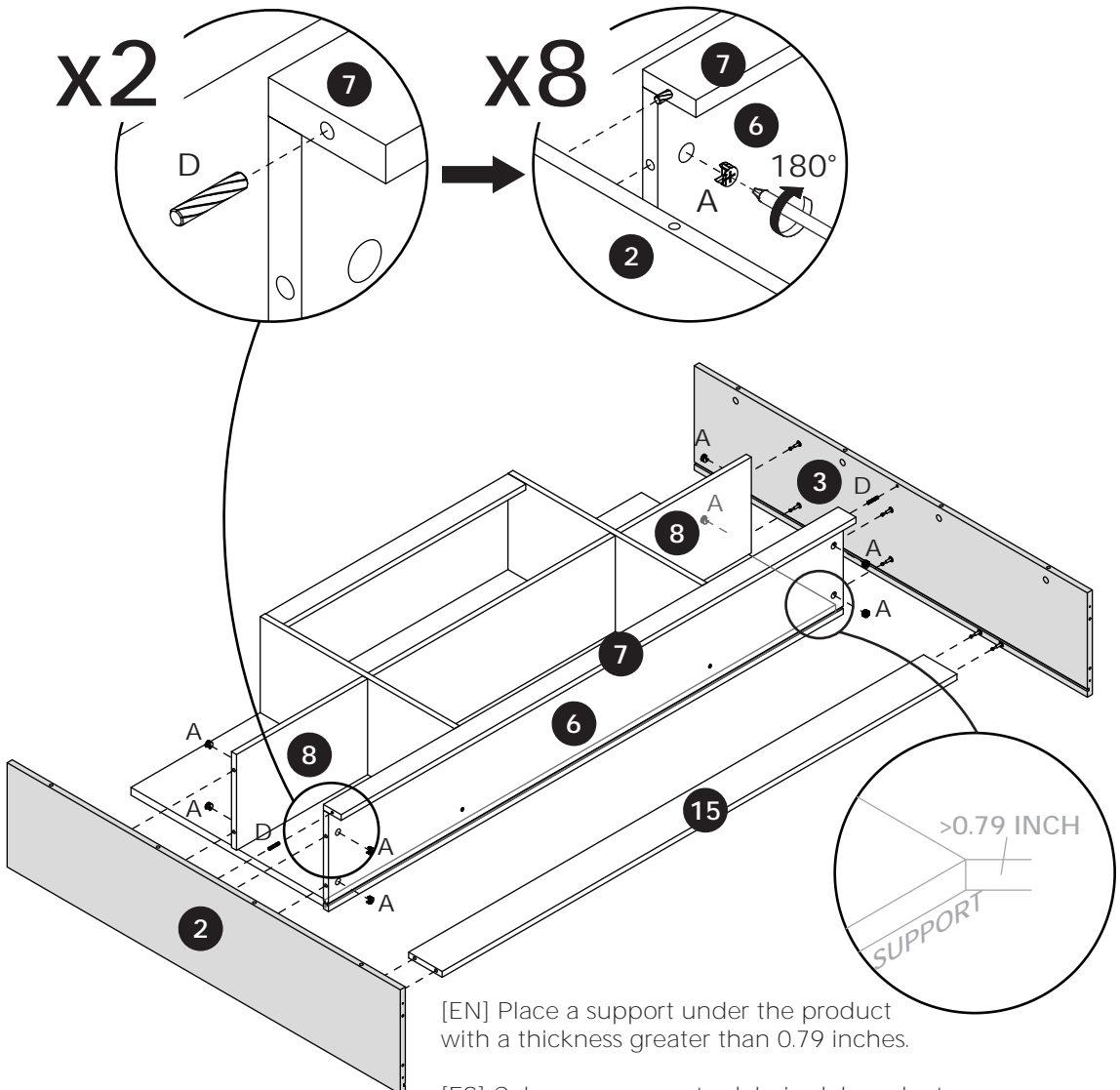

[EN] Place a support under the product with a thickness greater than 0.79 inches.

[ES] Coloque un soporte debajo del producto con un grosor superior a 0.79 pulgadas.

12



[EN] Attach component (C) to panel 16 and panel 17, then screw the self-tapping screw (B) into panel 16 and panel 17.

[ES] Fije el componente (C) al panel 16 y al panel 17, luego atornille el tornillo autorroscante (B) en el panel 16 y el panel 17.

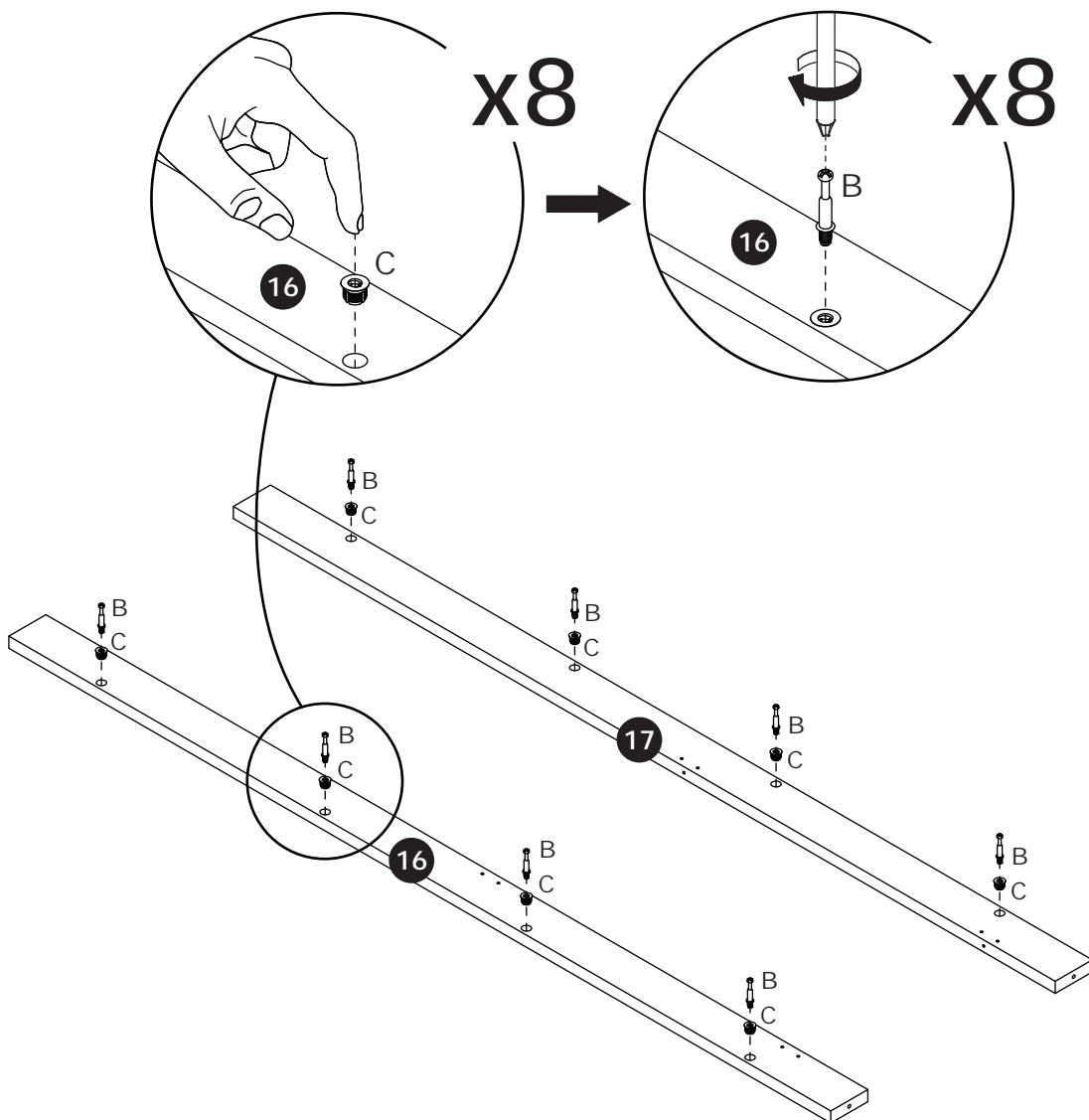

13



[EN] Attach panel 16 to panel 2 and panel 17 to panel 3, insert the eccentric cam (A), and tighten by turning clockwise.

[ES] Fije el panel 16 al panel 2 y el panel 17 al panel 3, inserte el excéntrico (A) y apriete girando en sentido horario.

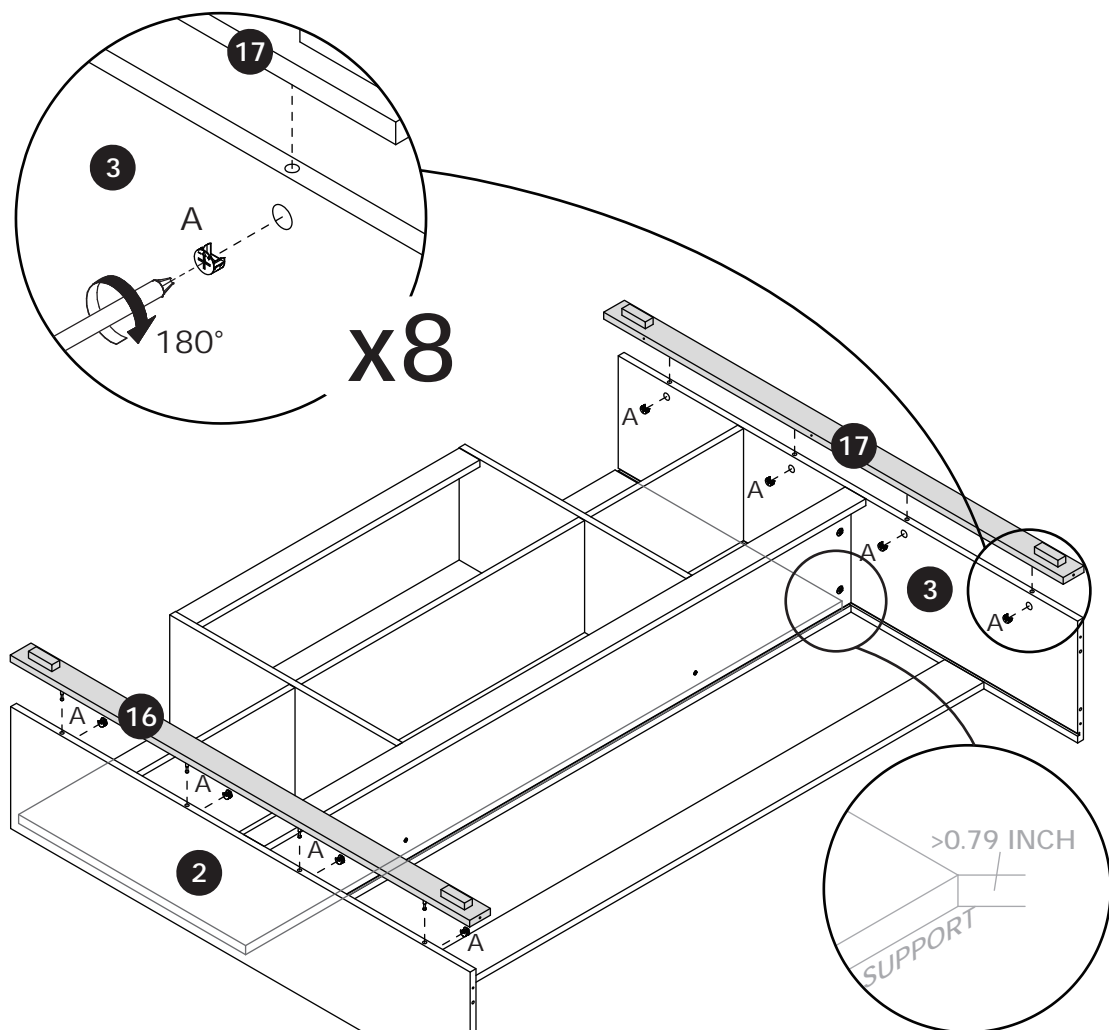

[EN] Place a support under the product with a thickness greater than 0.79 inches.

[ES] Coloque un soporte debajo del producto con un grosor superior a 0.79 pulgadas.

14



[EN] Flip the cabinet body, insert the eccentric cam (A) into panel 15, and tighten by turning clockwise.

[ES] Voltee el cuerpo del gabinete, inserte el excéntrico (A) en el panel 15 y apriete girando en sentido horario.

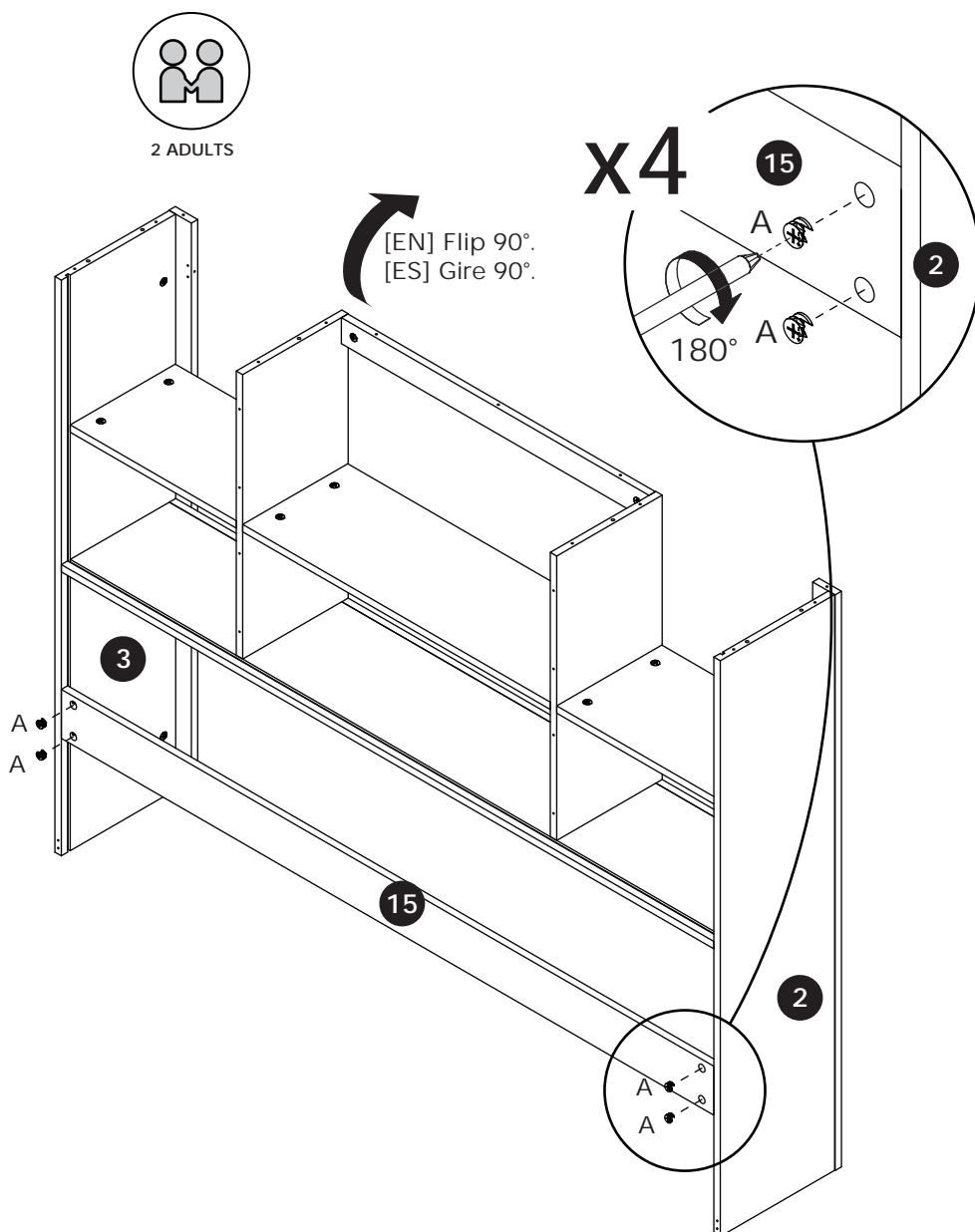

15

[EN] Insert panels 12 and 13 into the slots.

[ES] Inserte los paneles 12 y 13 en las ranuras.

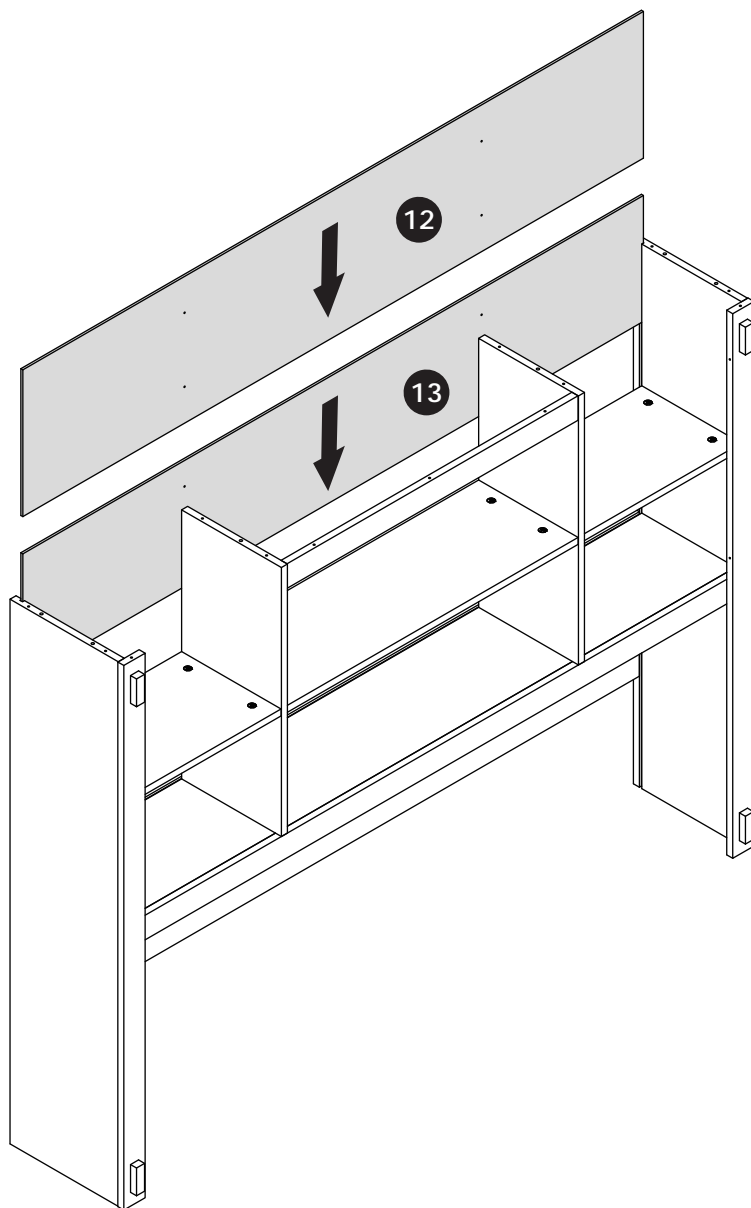

16



[EN] Attach component (L) to panel 1 with screws (N).

[ES] Fije el componente (L) al panel 1 con tornillos (N).

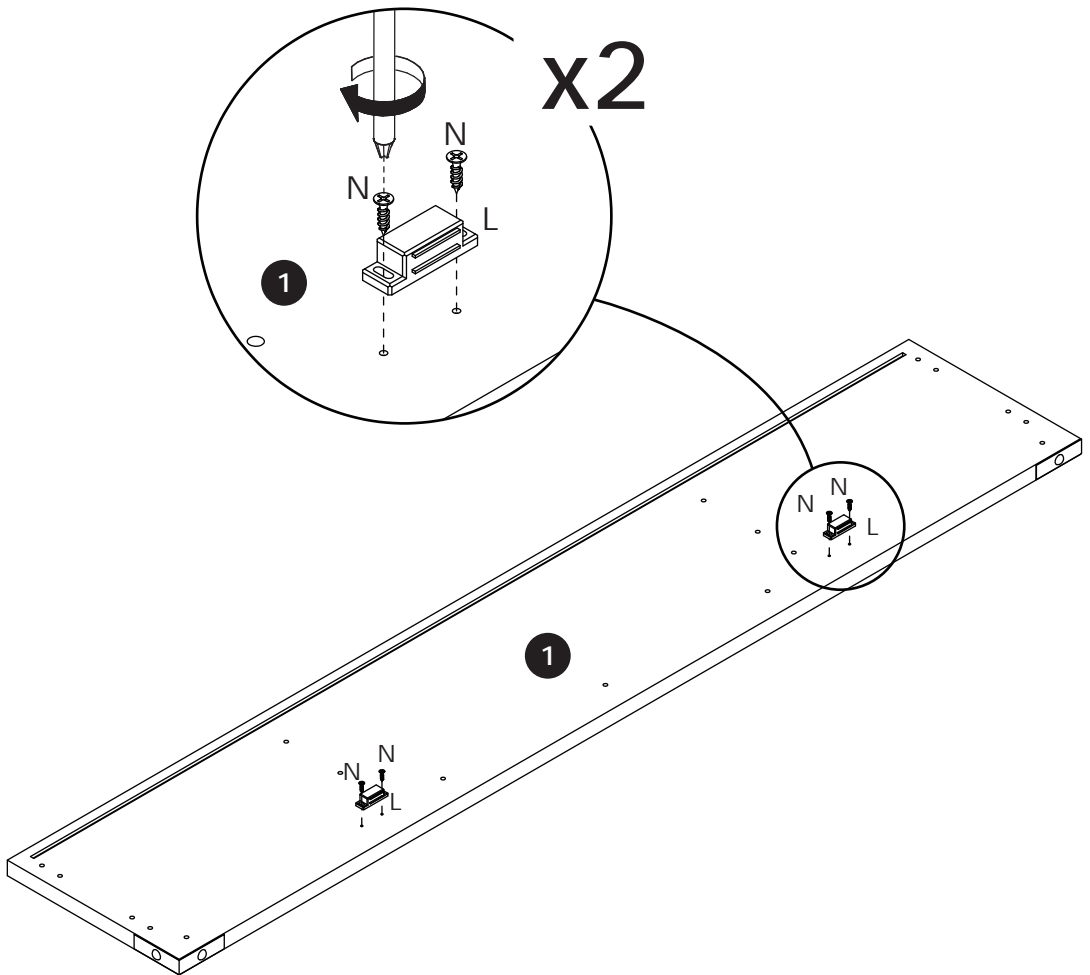

17



[EN] Insert the wooden dowel (D) into panels 2, 3, 4, and 5.

[ES] Inserte la espiga de madera (D) en los paneles 2, 3, 4 y 5.

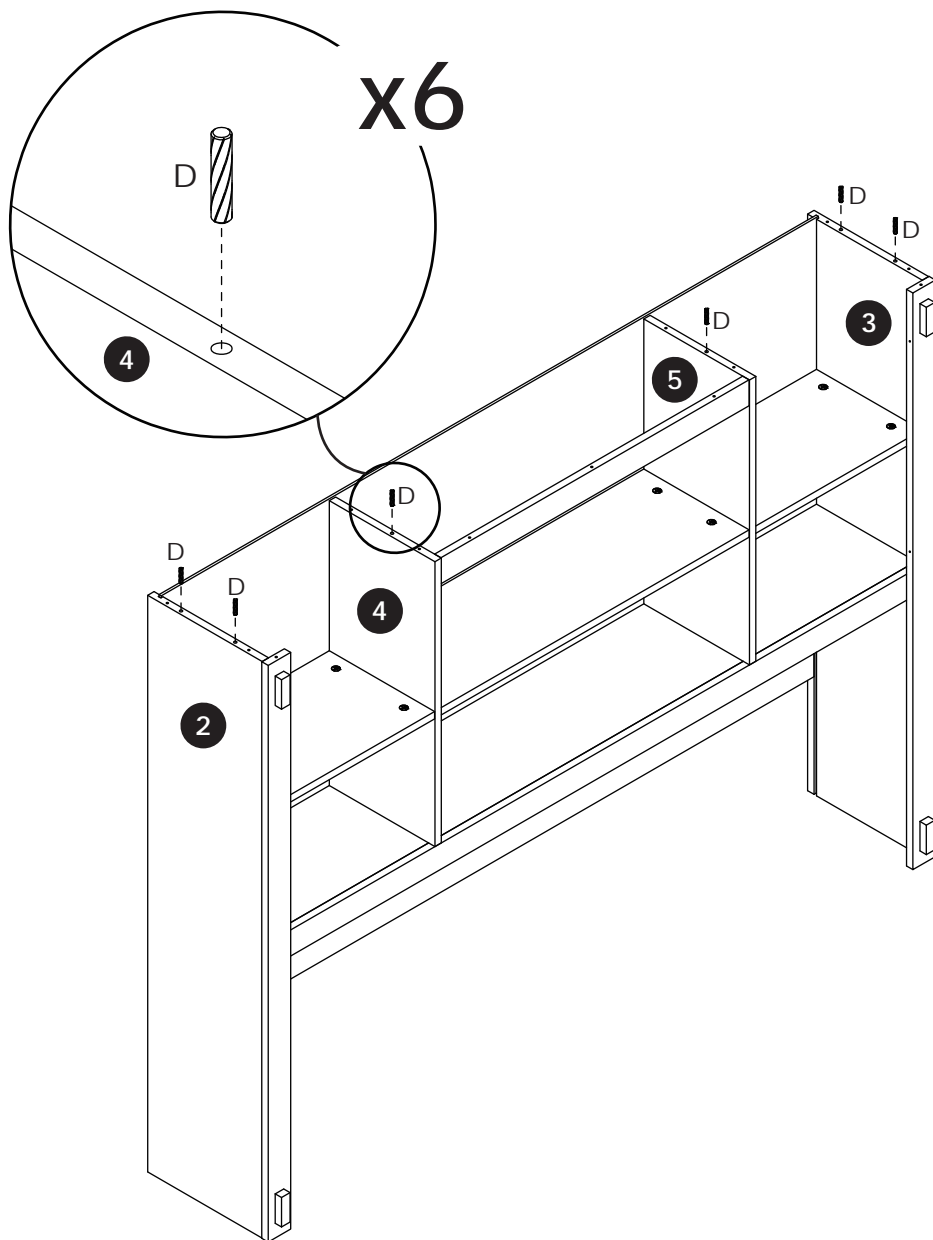

18



[EN] Attach panel 1 to the mounting unit with screws (E).

[ES] Fije el panel 1 al soporte de montaje con tornillos (E).

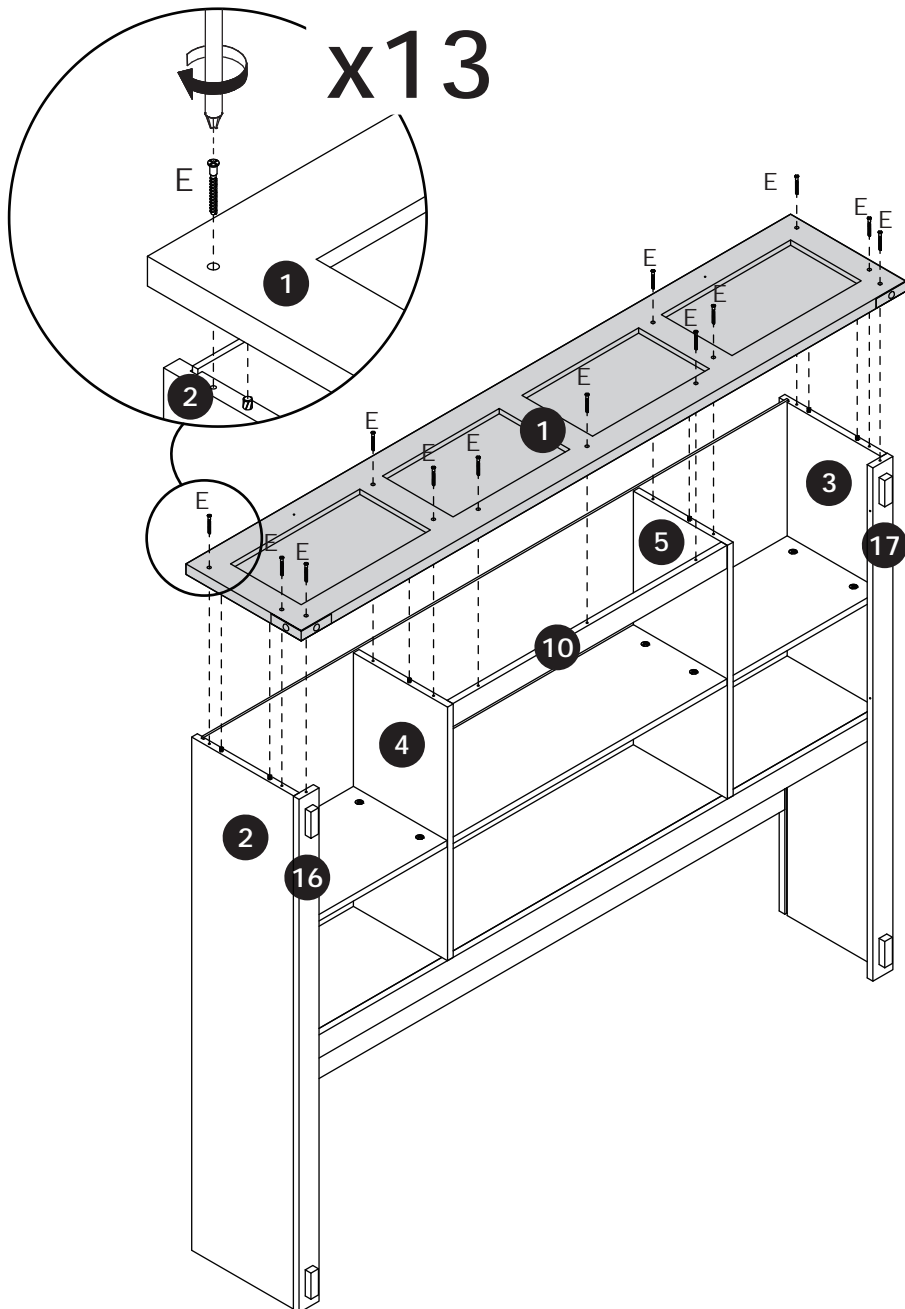

19

[EN] Flip the cabinet body and insert panel 14 into the slots.

[ES] Voltee el gabinete e inserte el panel 14 en las ranuras.



2 ADULTS

[EN] Flip 180°.
[ES] Gire 180°.

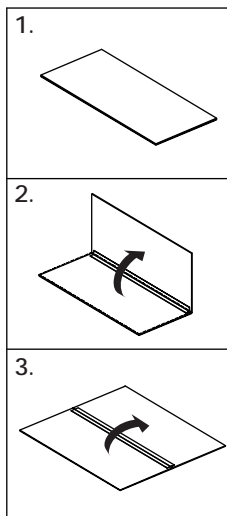
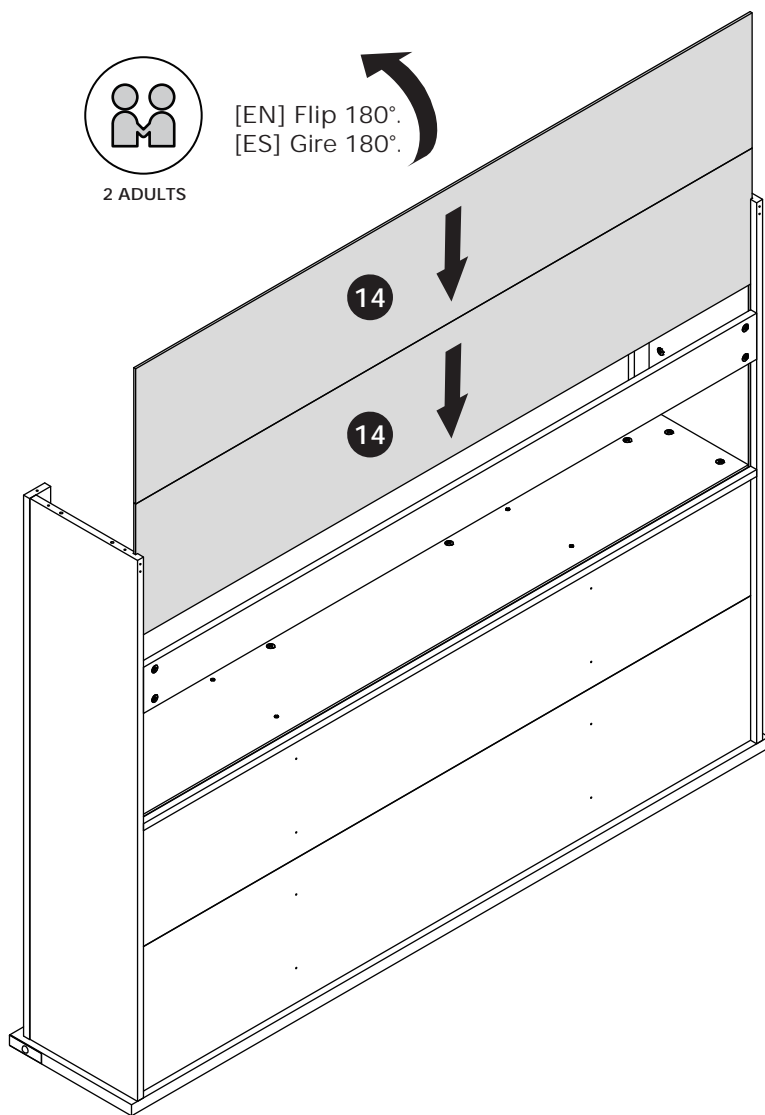

20



[EN] Attach component (C) to panel 20, then screw the self-tapping screw (B) into panel 20.

[ES] Fije el componente (C) al panel 20, luego atornille el tornillo autorroscante (B) en el panel 20.

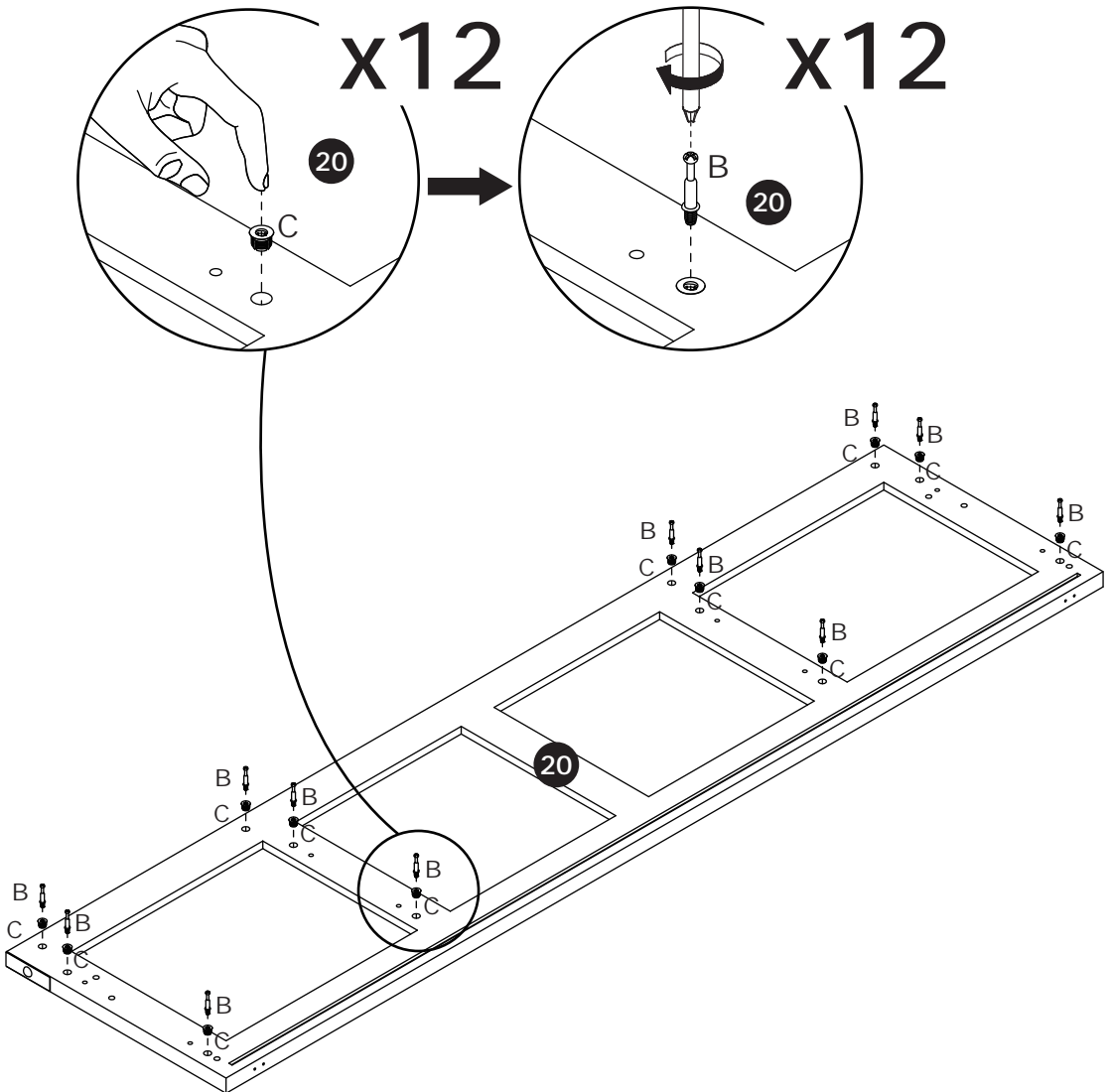

21



[EN] Attach panel 20 to the mounting unit with wooden dowel (D) and secure with screws (E).

[ES] Fije el panel 20 a la unidad de montaje con espigas de madera (D) y fíjelo con tornillos (E).

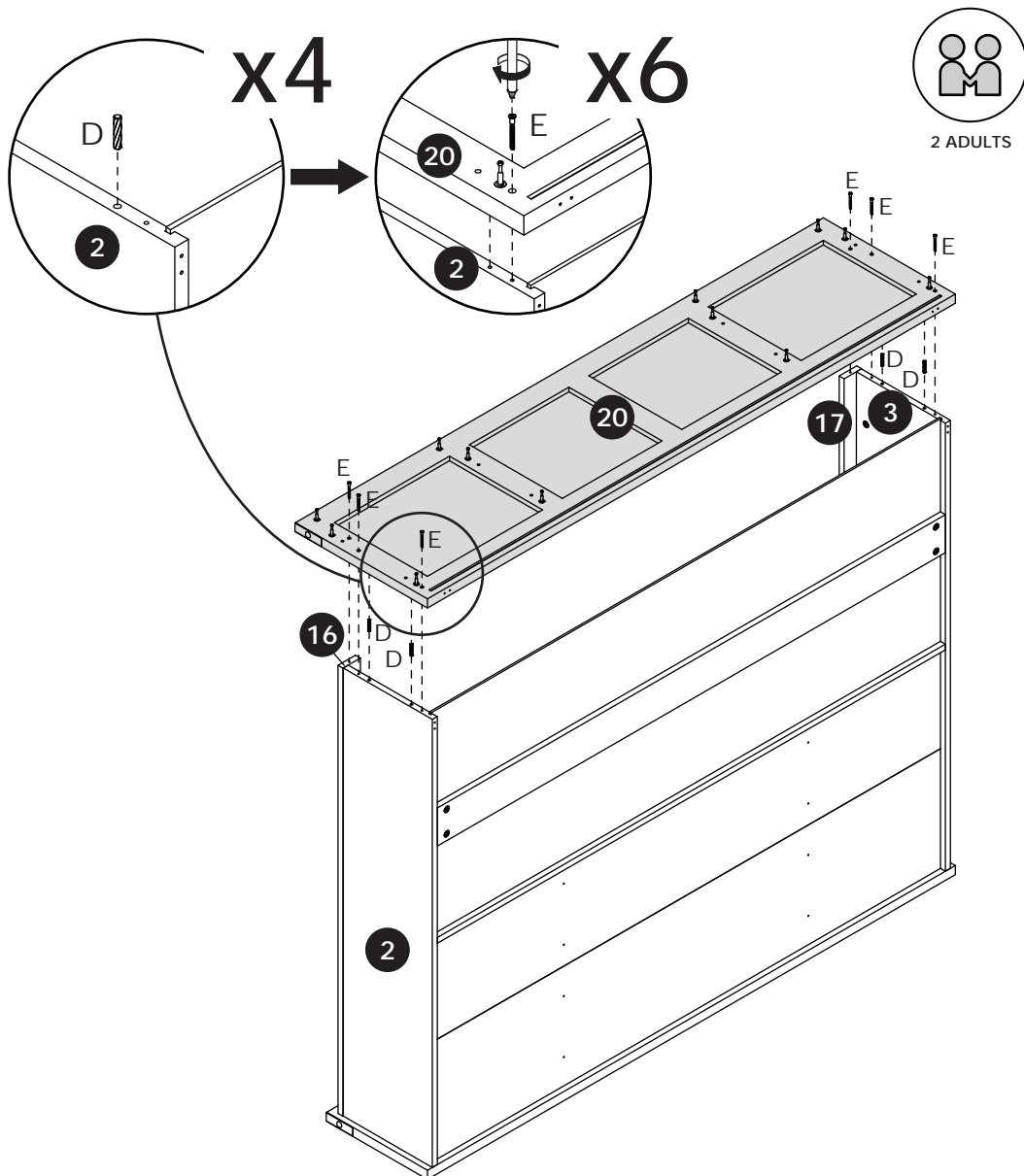

22



[EN] Attach component (C) to panels 43 and 44, then screw the self-tapping screw (B) into panels 43 and 44.

[ES] Fije el componente (C) a los paneles 43 y 44, luego atornille el tornillo autorroscante (B) en los paneles 43 y 44.

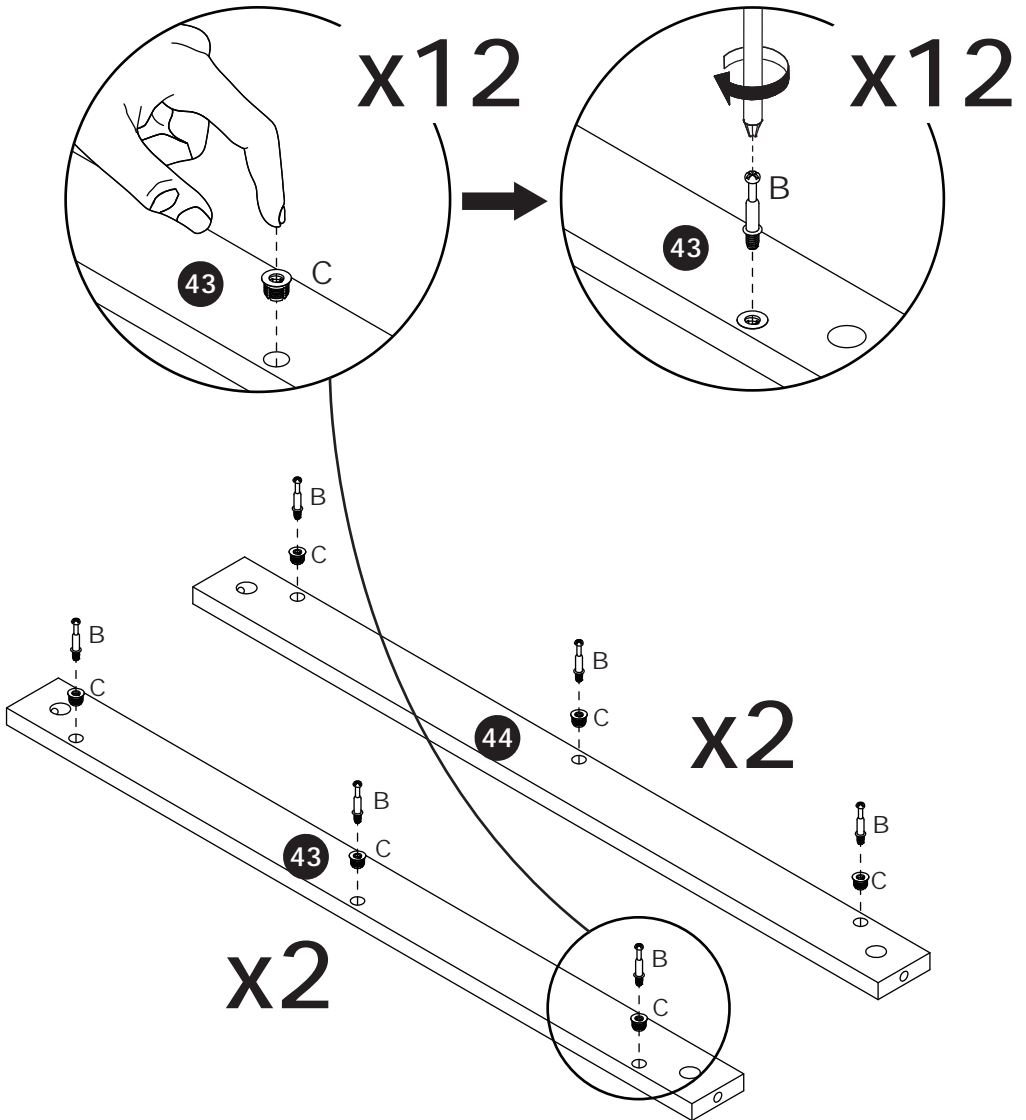

23



[EN] Attach panel 43 to panel 21 and panel 44 to panel 23, insert the eccentric cam (A), and tighten by turning clockwise.

[ES] Fije el panel 43 al panel 21 y el panel 44 al panel 23, inserte el excéntrico (A) y apriete girando en sentido horario.

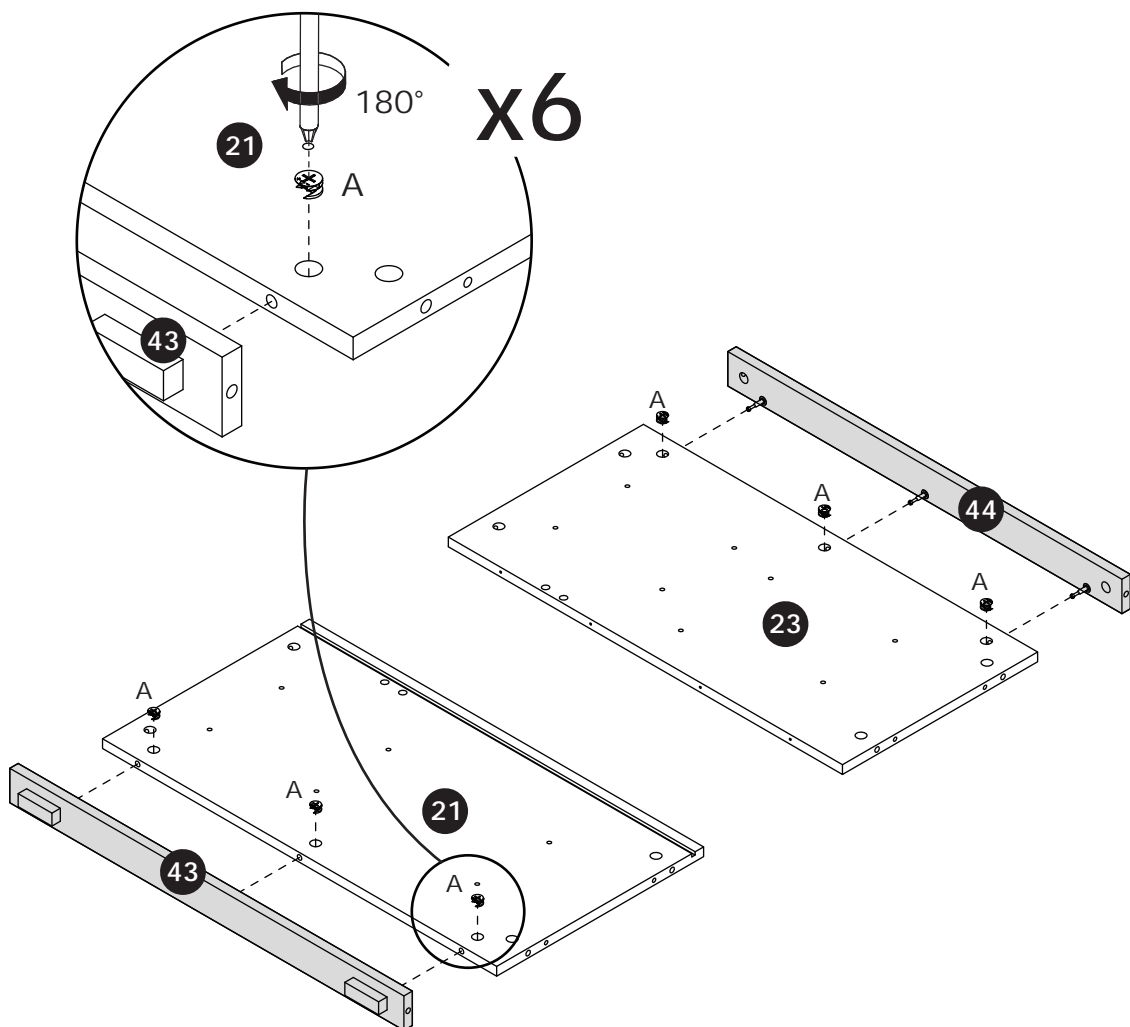

24



[EN] Attach panel 44 to panel 24 and panel 43 to panel 22, insert the eccentric cam (A), and tighten by turning clockwise.

[ES] Fije el panel 44 al panel 24 y el panel 43 al panel 22, inserte el excéntrico (A) y apriete girando en sentido horario.

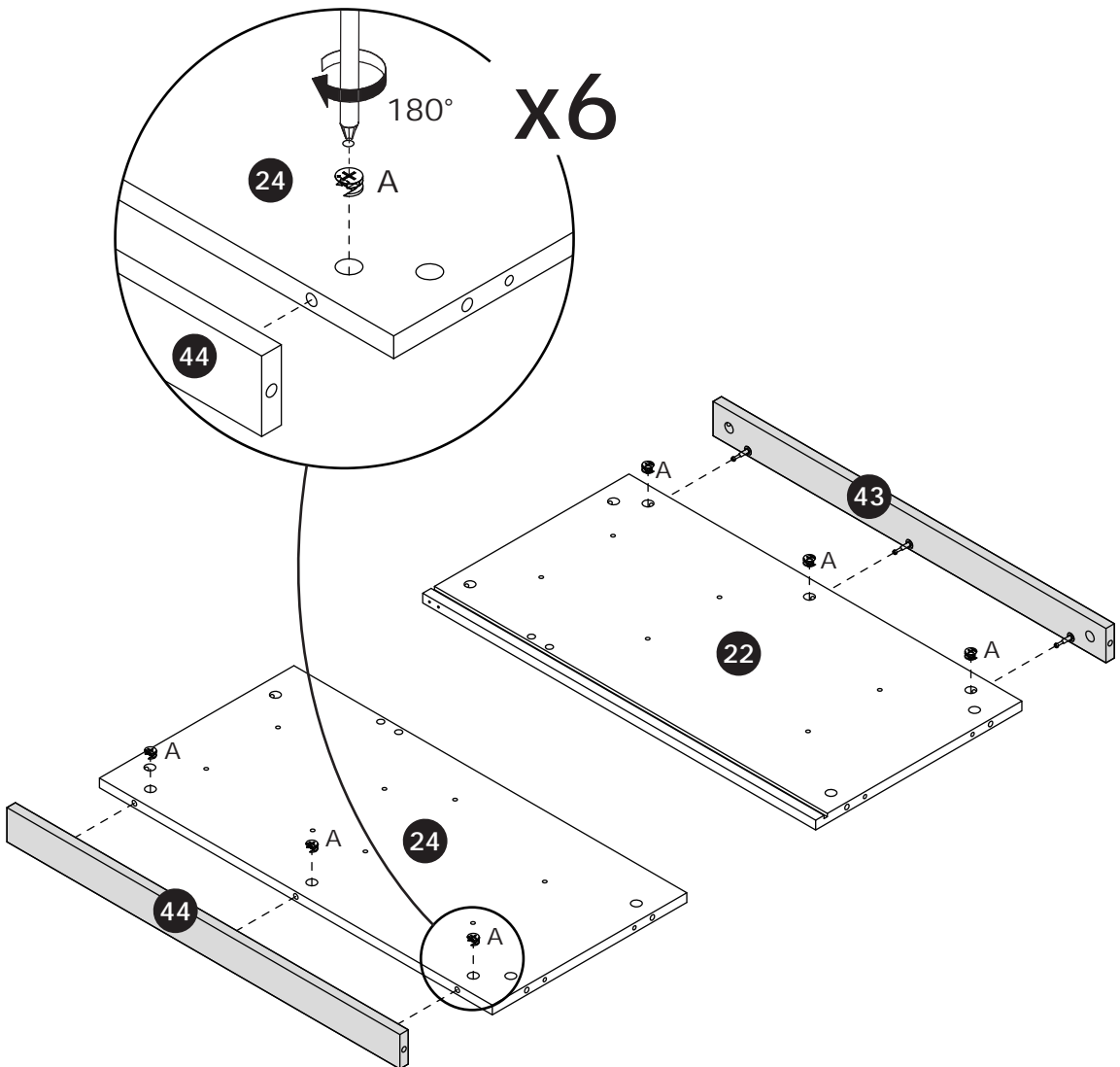

25



[EN] Insert the wooden dowel (D) into panel 42.

[ES] Inserte la espiga de madera (D) en el panel 42.

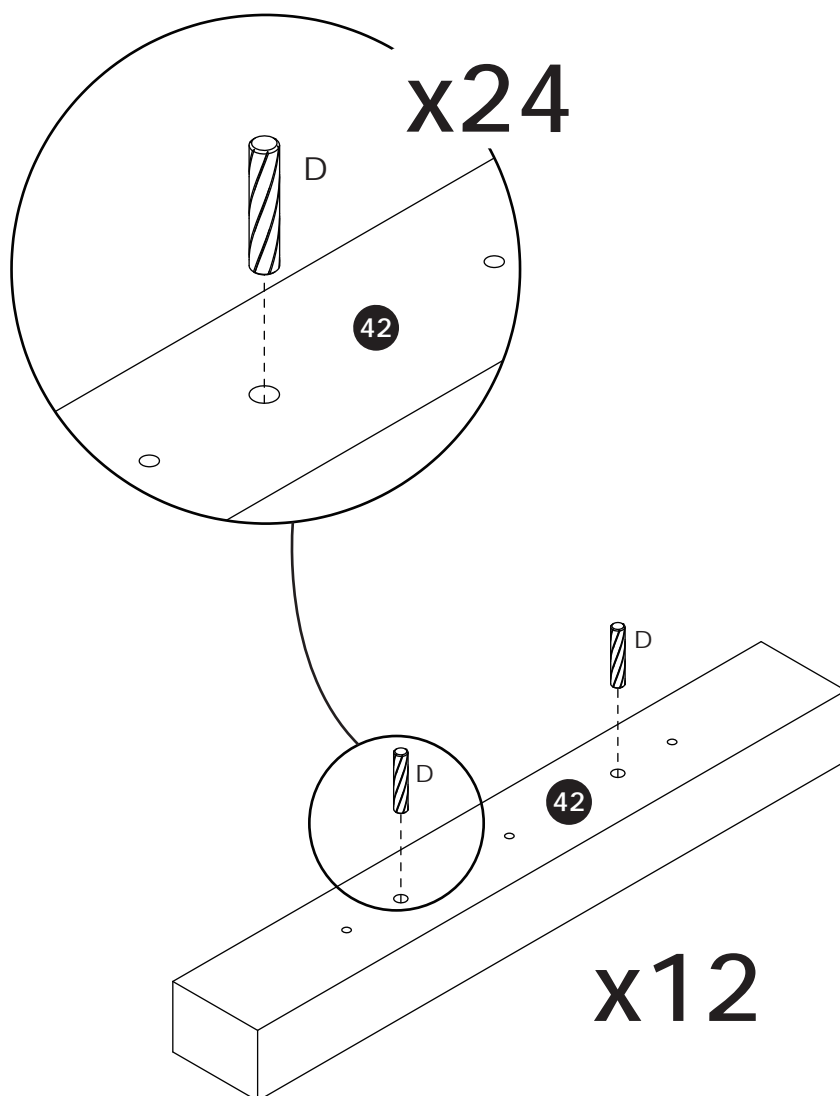

26



[EN] Attach panel 42 to panels 21 and 23 with screws (V).

[ES] Fije el panel 42 a los paneles 21 y 23 con tornillos (V).

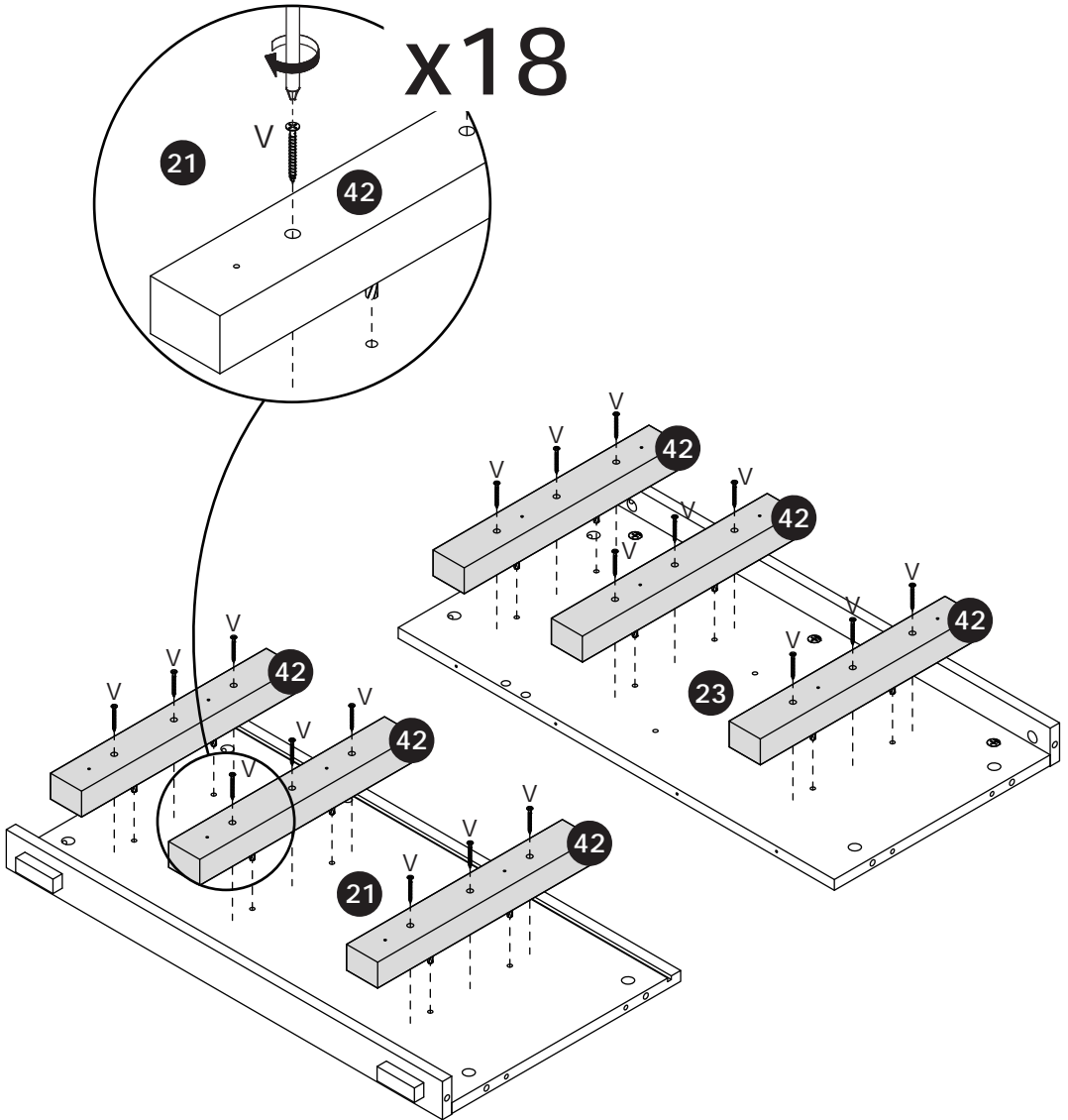

27



[EN] Attach panel 42 to panels 22 and 24 with screws (V).

[ES] Fije el panel 42 a los paneles 22 y 24 con tornillos (V).

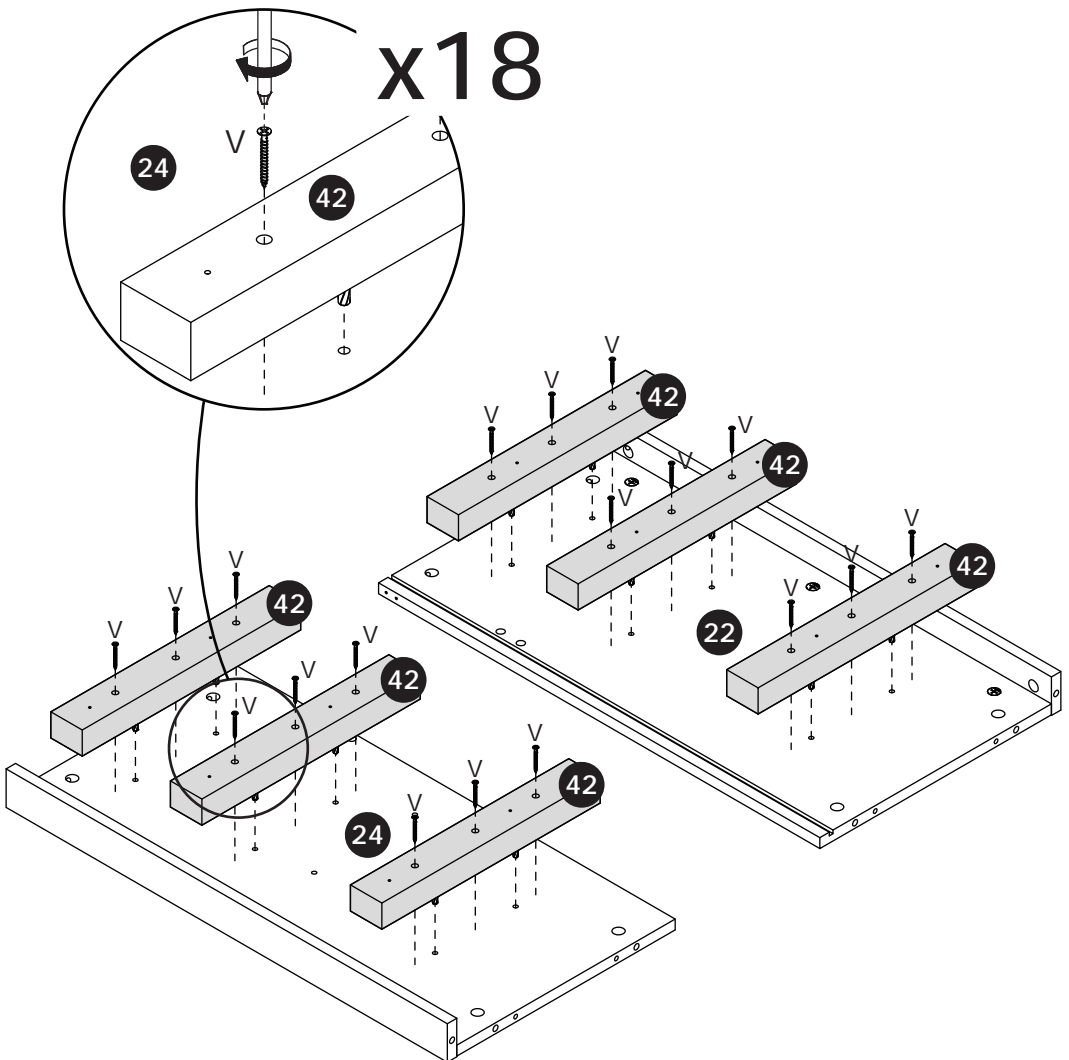

28



[EN] Attach slide rail (F-1) to panel 42 with screws (G).

[ES] Fije el riel deslizante (F-1) al panel 42 con tornillos (G).

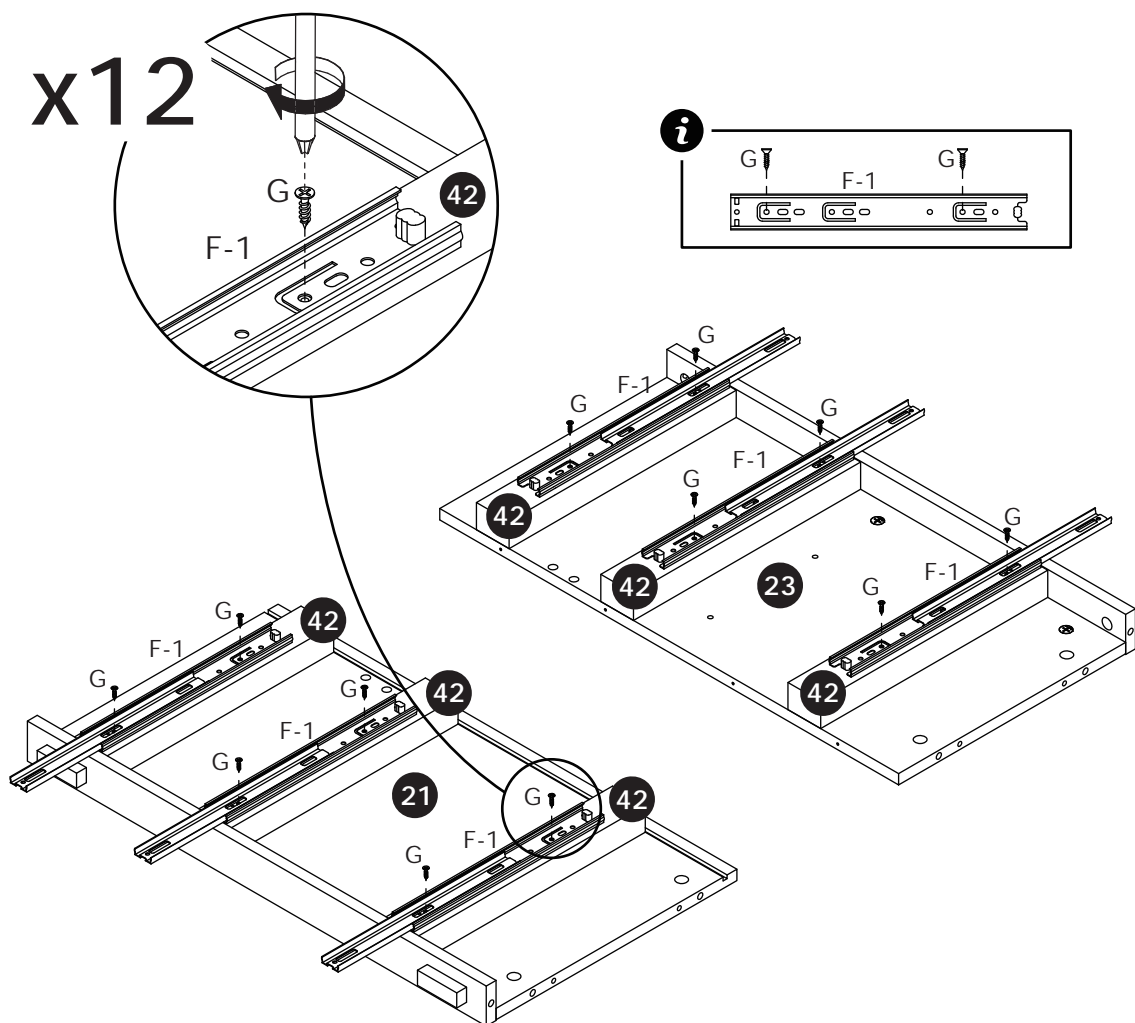

29



[EN] Attach component (C) to panels 21 and 23, then screw the self-tapping screw (B) into panels 21 and 23.

[ES] Fije el componente (C) a los paneles 21 y 23, luego atornille el tornillo autorroscante (B) en los paneles 21 y 23.

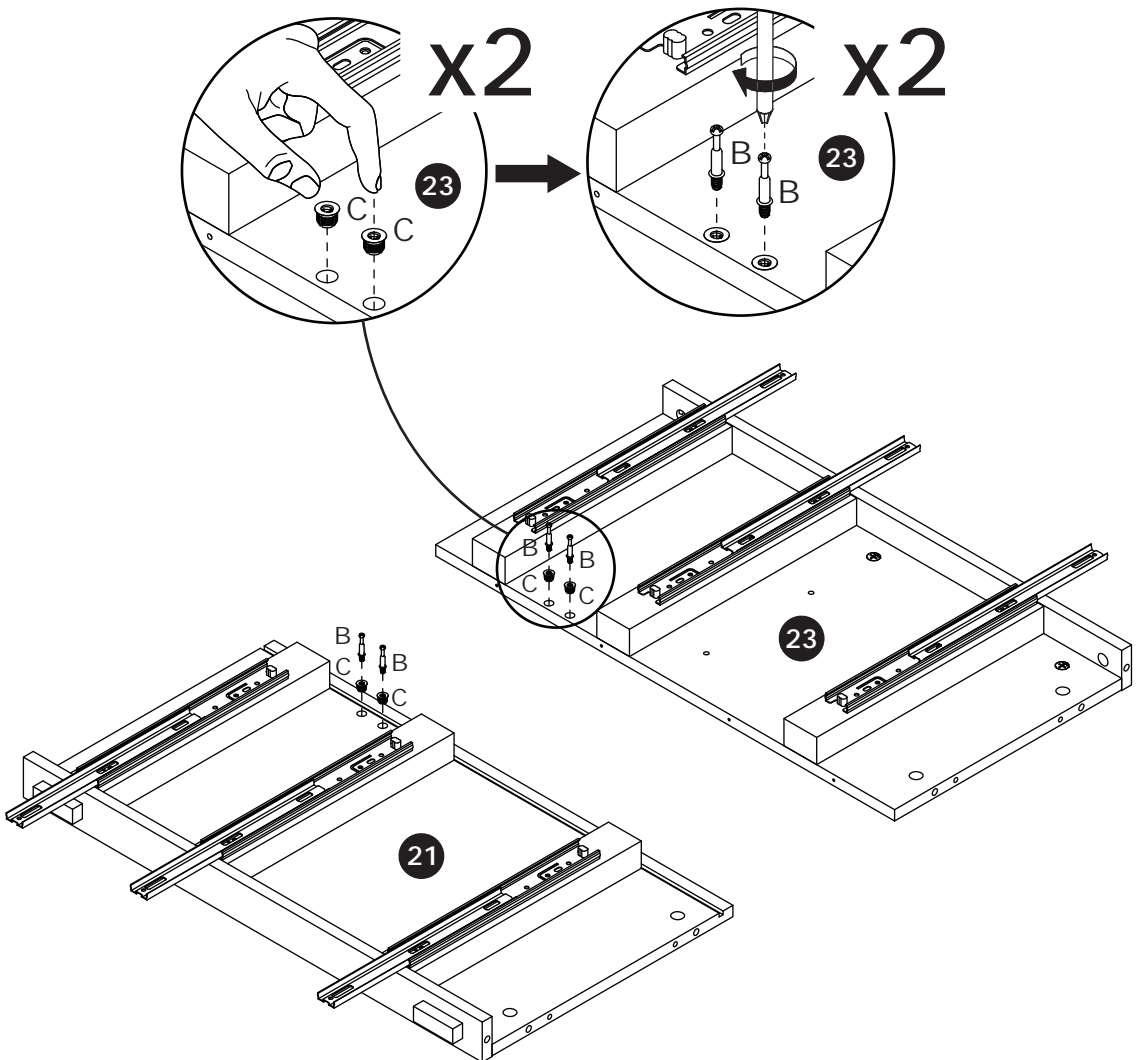

30

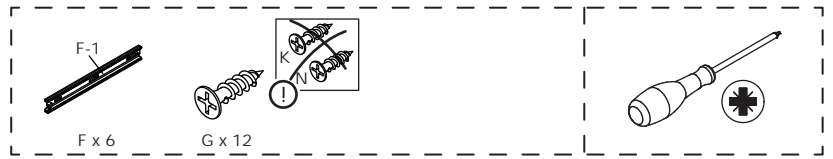

[EN] Attach slide rail (F-1) to panel 42 with screws (G).

[ES] Fije el riel deslizante (F-1) al panel 42 con tornillos (G).

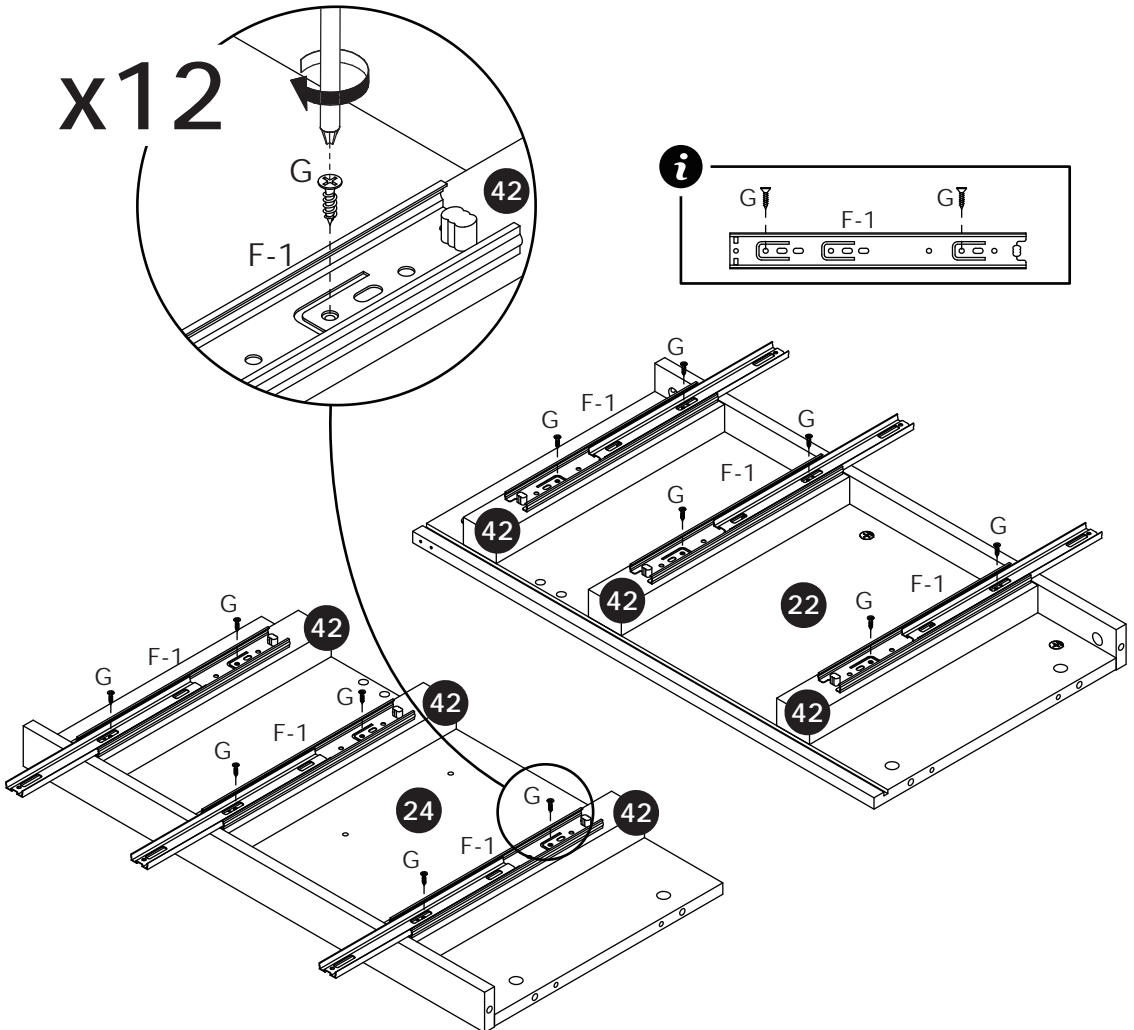

31



[EN] Attach component (C) to panels 22 and 24, then screw the self-tapping screw (B) into panels 22 and 24.

[ES] Fije el componente (C) a los paneles 22 y 24, luego atornille el tornillo autorroscante (B) en los paneles 22 y 24.

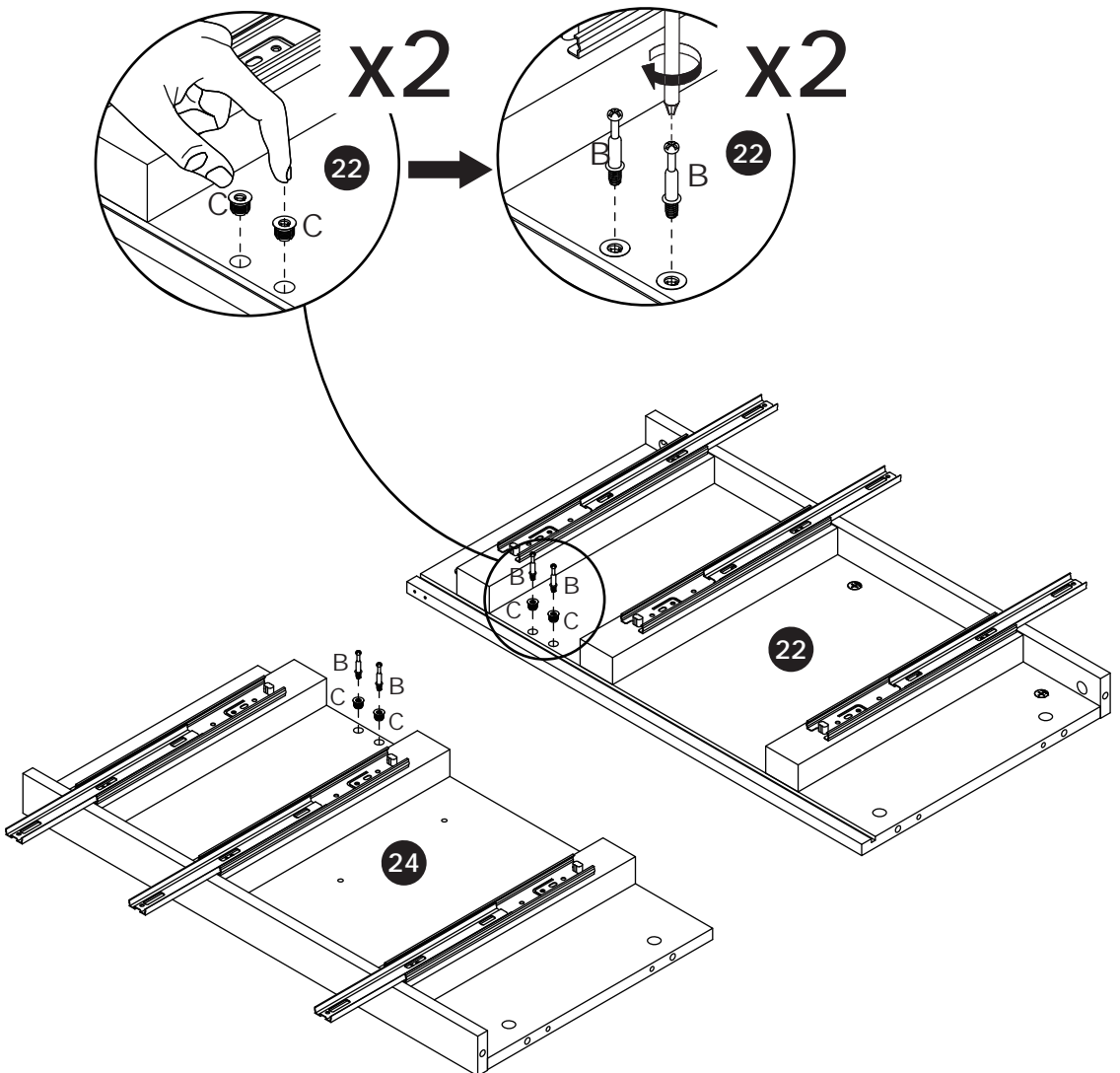

32



[EN] Attach panels 23 and 24 to panel 26 with screws (E).

[ES] Fije los paneles 23 y 24 al panel 26 con tornillos (E).

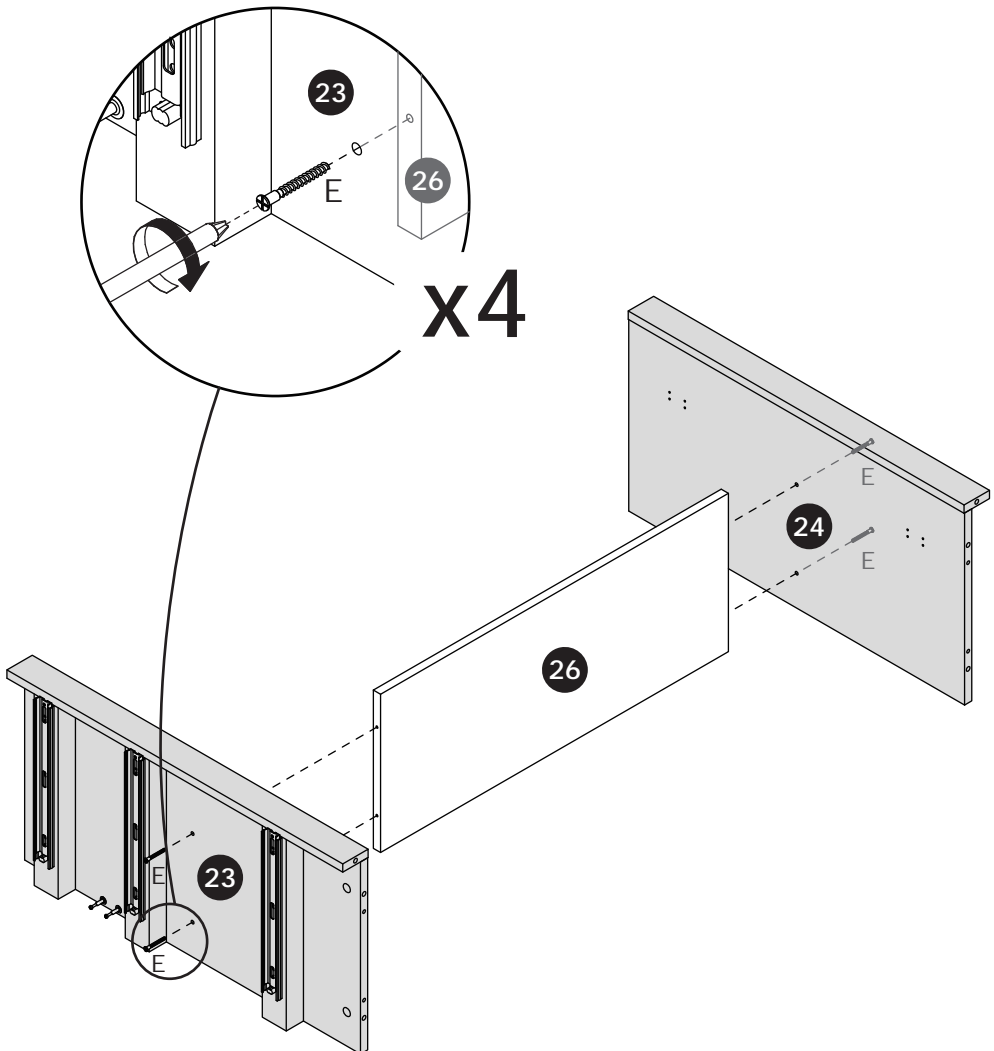

33



[EN] Attach panel 11 to panels 21 and 23, insert the eccentric cam (A), and tighten by turning clockwise.

[ES] Fije el panel 11 a los paneles 21 y 23, inserte el excéntrico (A) y apriete girando en sentido horario.

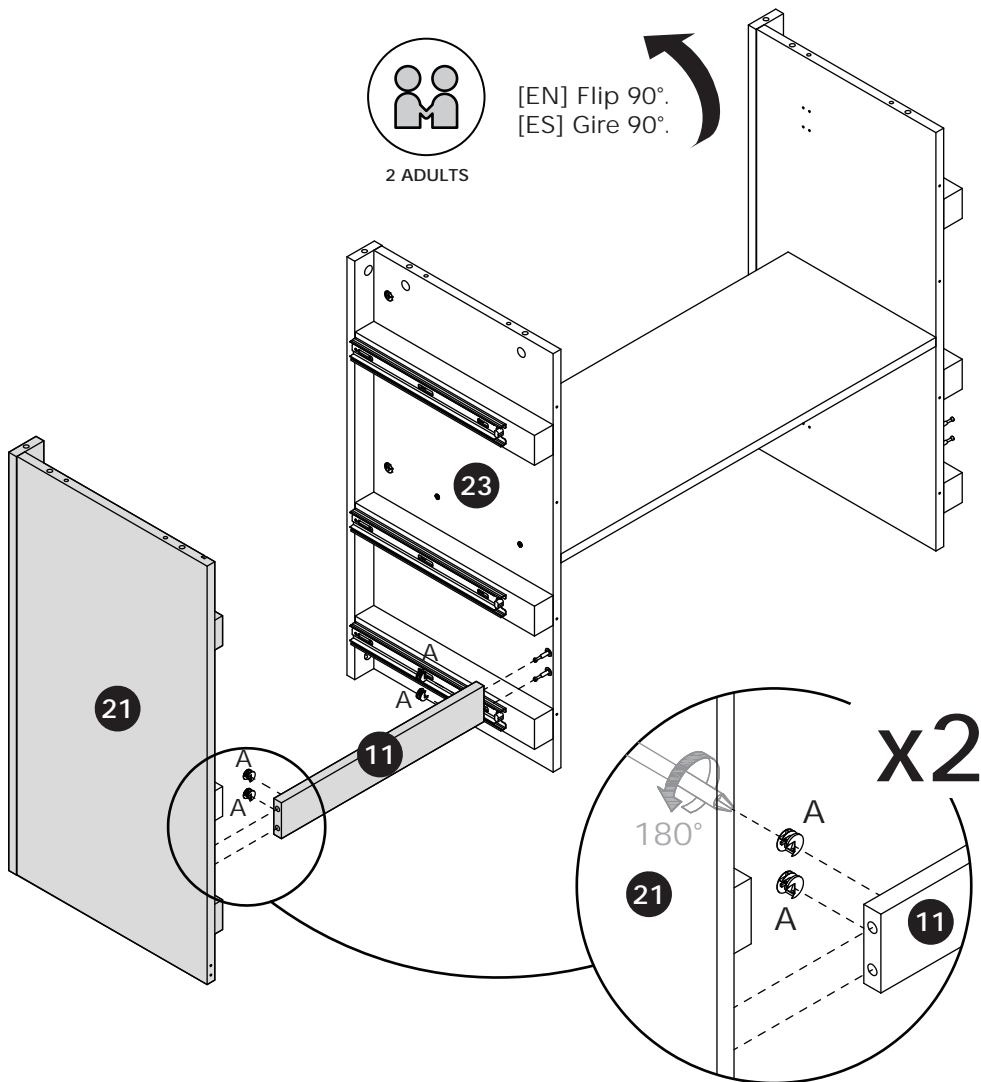

34



[EN] Attach panel 11 to panels 22 and 24, insert the eccentric cam (A), and tighten by turning clockwise.

[ES] Fije el panel 11 a los paneles 22 y 24, inserte el excéntrico (A) y apriete girando en sentido horario.

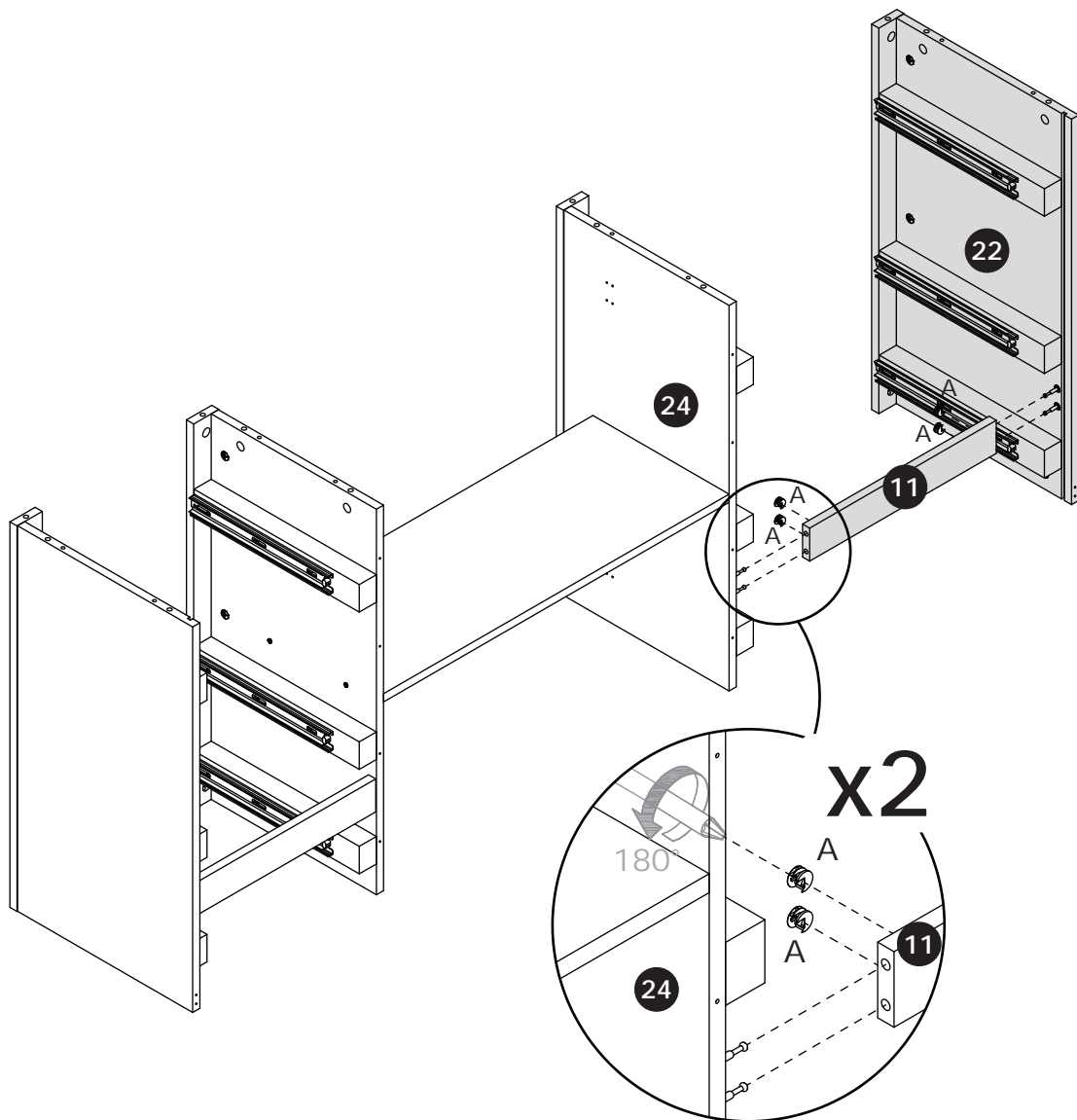

35



[EN] Attach support leg 40 to panel 25 with wooden dowel (D) and secure with screws (E).

[ES] Fije la pata de soporte 40 al panel 25 con espigas de madera (D) y fijela con tornillos (E).

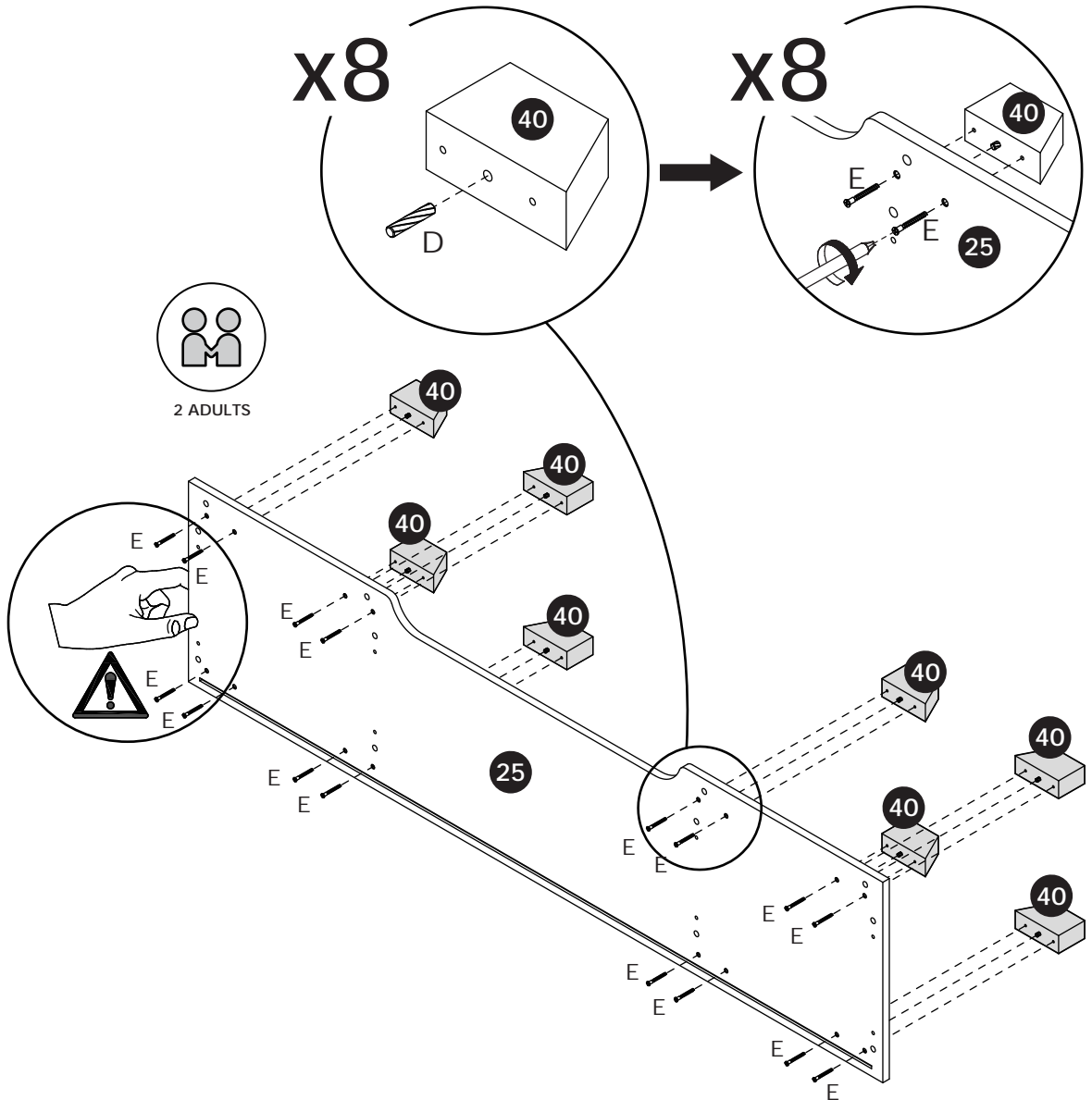

36

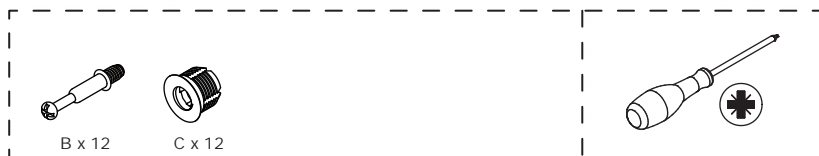

[EN] Attach component (C) to panel 25, then screw the self-tapping screw (B) into panel 25.

[ES] Fije el componente (C) al panel 25, luego atornille el tornillo autorroscante (B) en el panel 25.

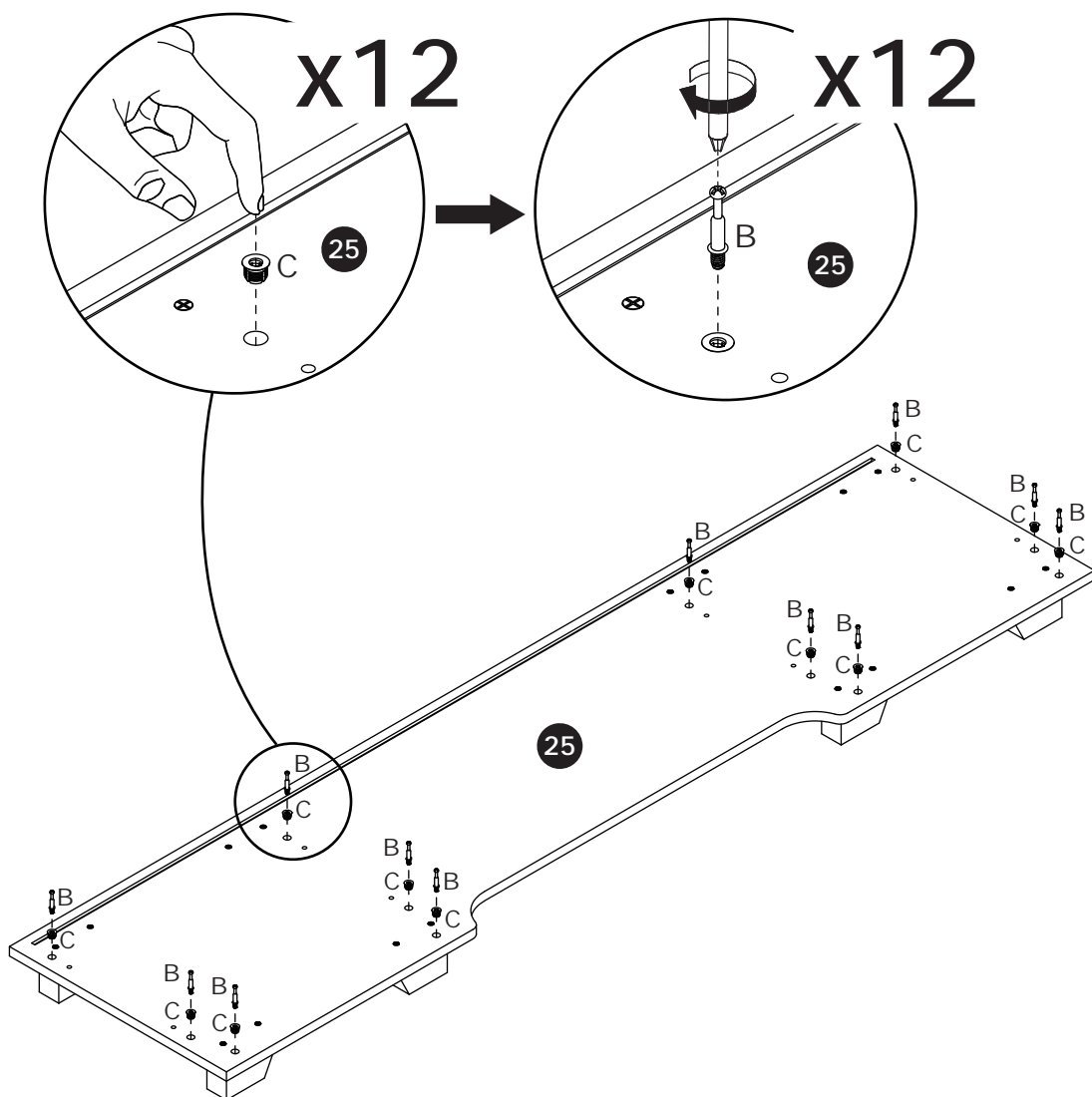

38



[EN] Attach panel 25 to the mounting unit, insert the eccentric cam (A), and tighten by turning clockwise.

[ES] Fije el panel 25 a la unidad de montaje, inserte el excéntrico (A) y apriete girando en sentido horario.

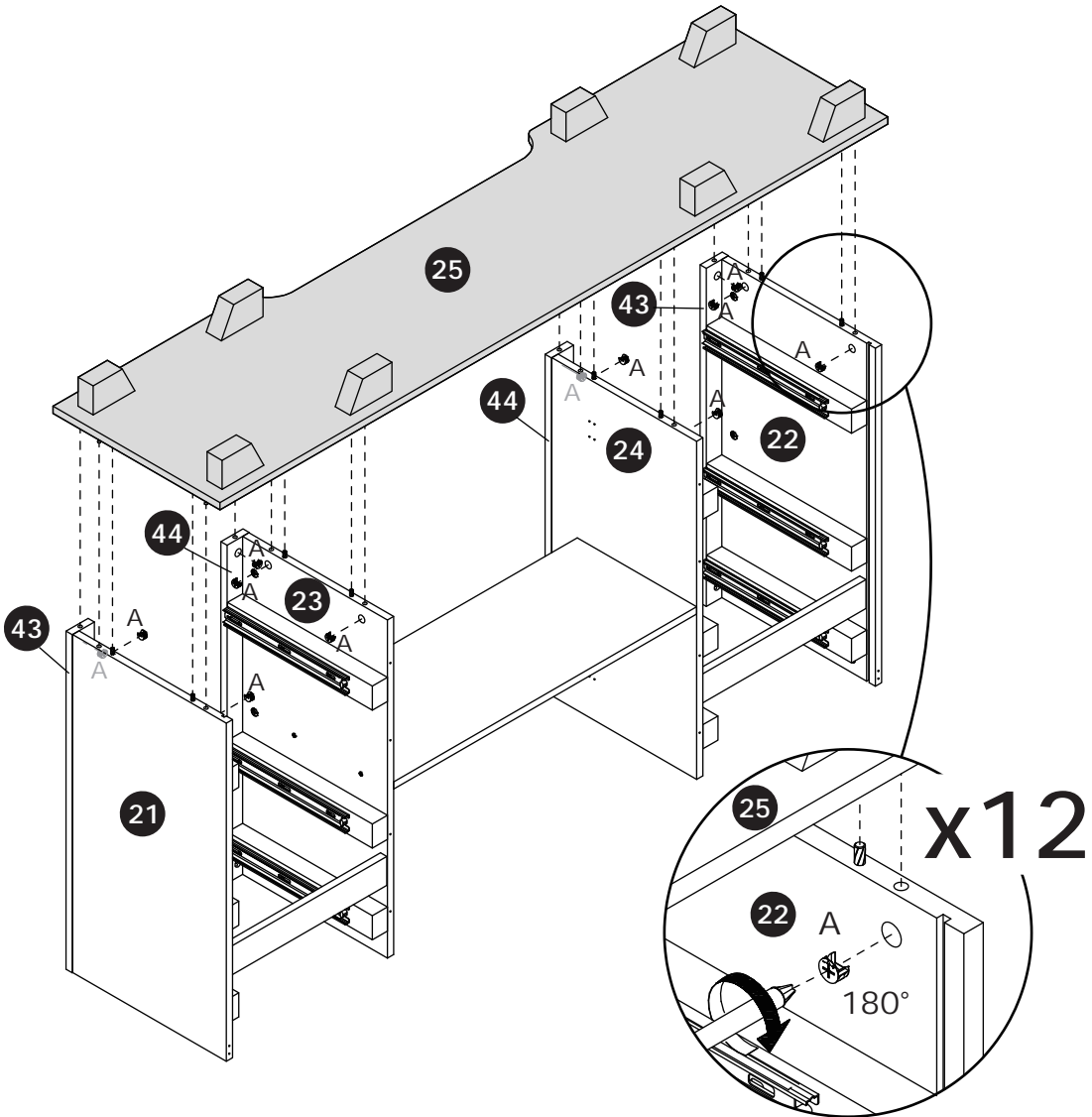

39

[EN] Flip the cabinet and insert panel 41 into the slot.

[ES] Voltee el gabinete e inserte el panel 41 en la ranura.



2 ADULTS

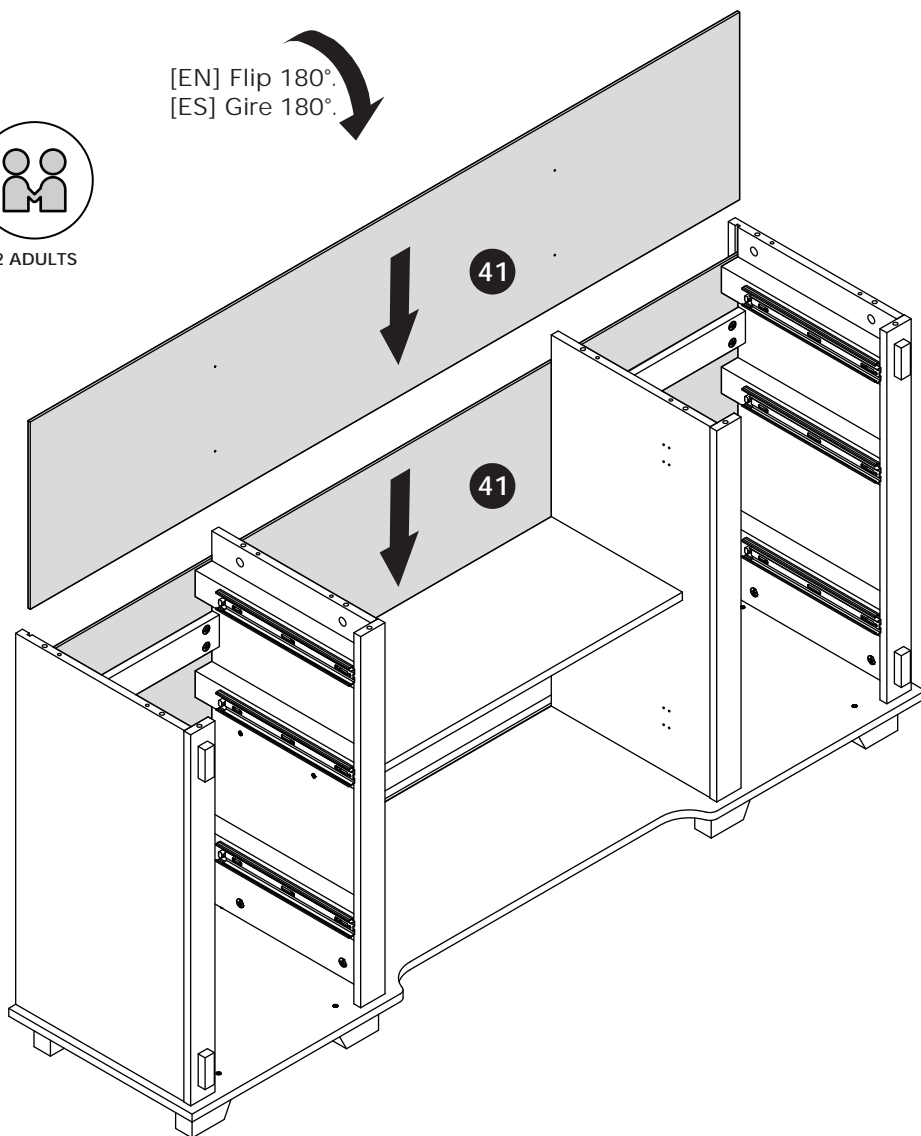

40



[EN] Insert the wooden dowel (D) into panels 21, 22, 23, and 24.

[ES] Inserte la clavija de madera (D) en los paneles 21, 22, 23 y 24.

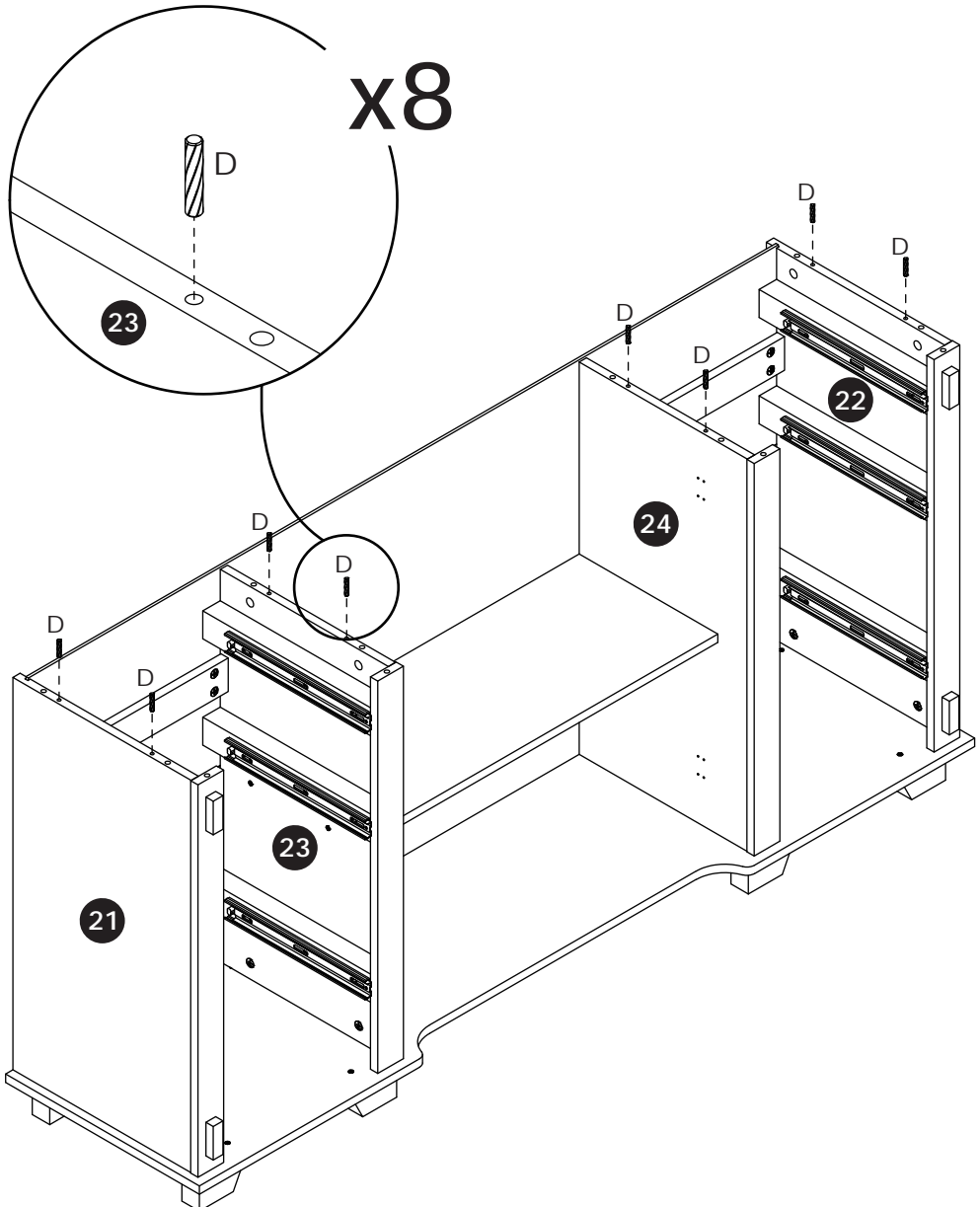

41



A x 12

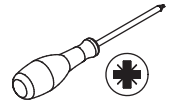

[EN] Attach panel 20 to the mounting unit, insert the eccentric cam (A), and tighten clockwise. **Caution: Avoid pinching fingers.**

[ES] Fije el panel 20 a la unidad de montaje, inserte la leva excéntrica (A) y apriete en el sentido de las agujas del reloj. **Precaución: Evite pellizcarse los dedos.**

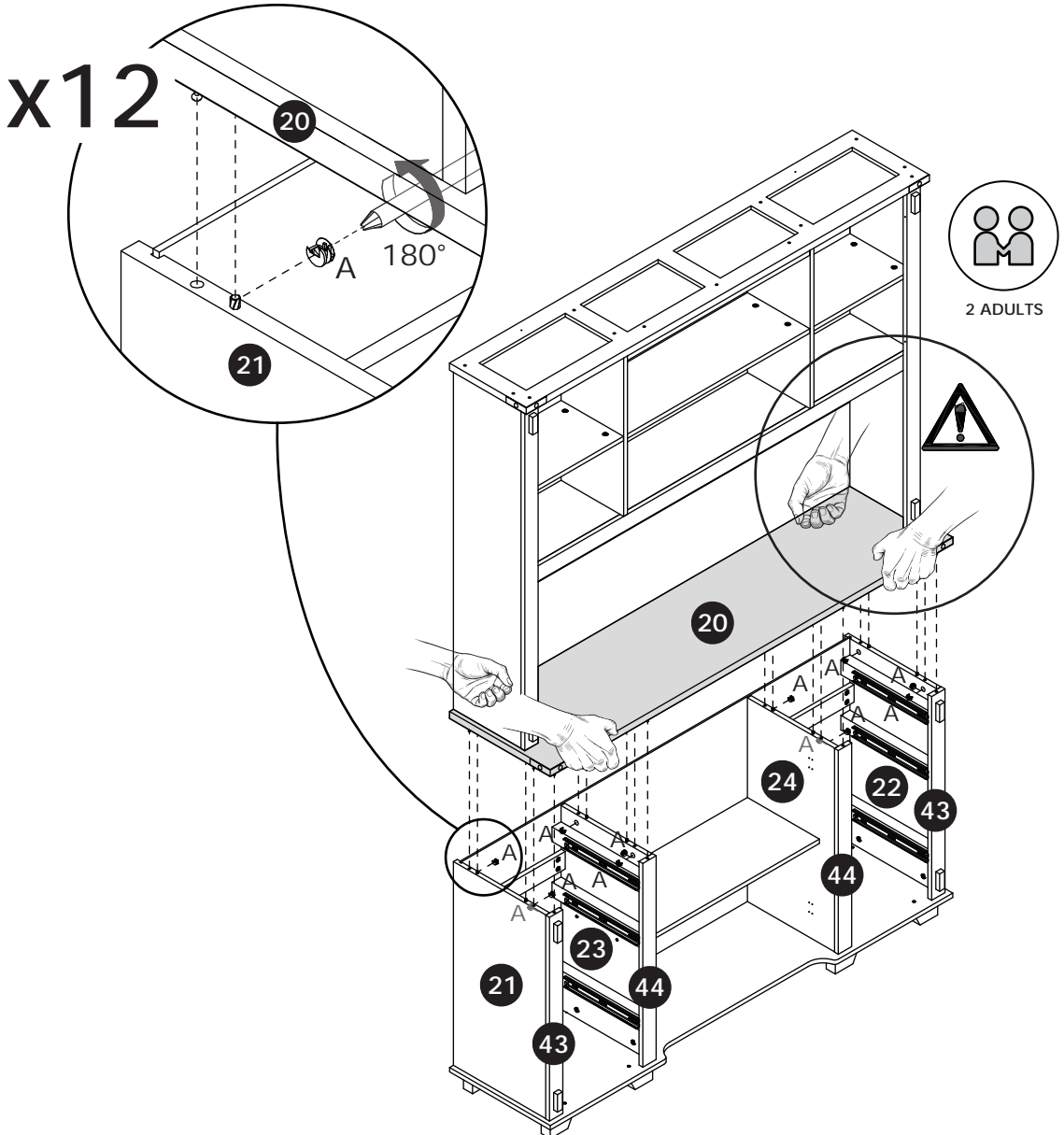

42



[EN] Secure component (X) to panels 2, 3, 20, 21, and 22 with screws (K).

[ES] Fije el componente (X) a los paneles 2, 3, 20, 21 y 22 con tornillos (K).

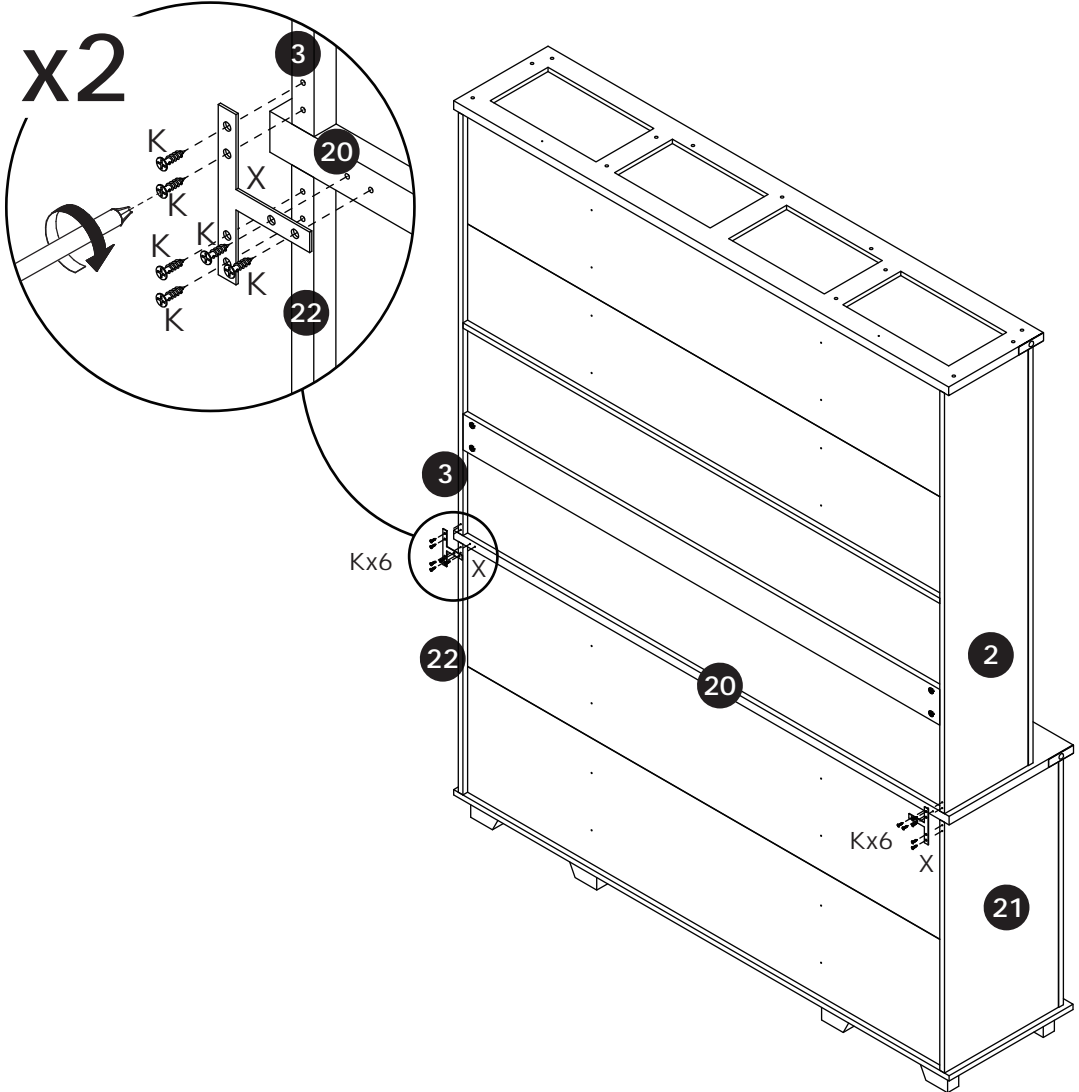

43



[EN] Secure panels 12 and 13 to panels 4 and 5, and panel 41 to panels 23 and 24 with screws (Y).

[ES] Fije los paneles 12 y 13 a los paneles 4 y 5, y el panel 41 a los paneles 23 y 24 con tornillos (Y).

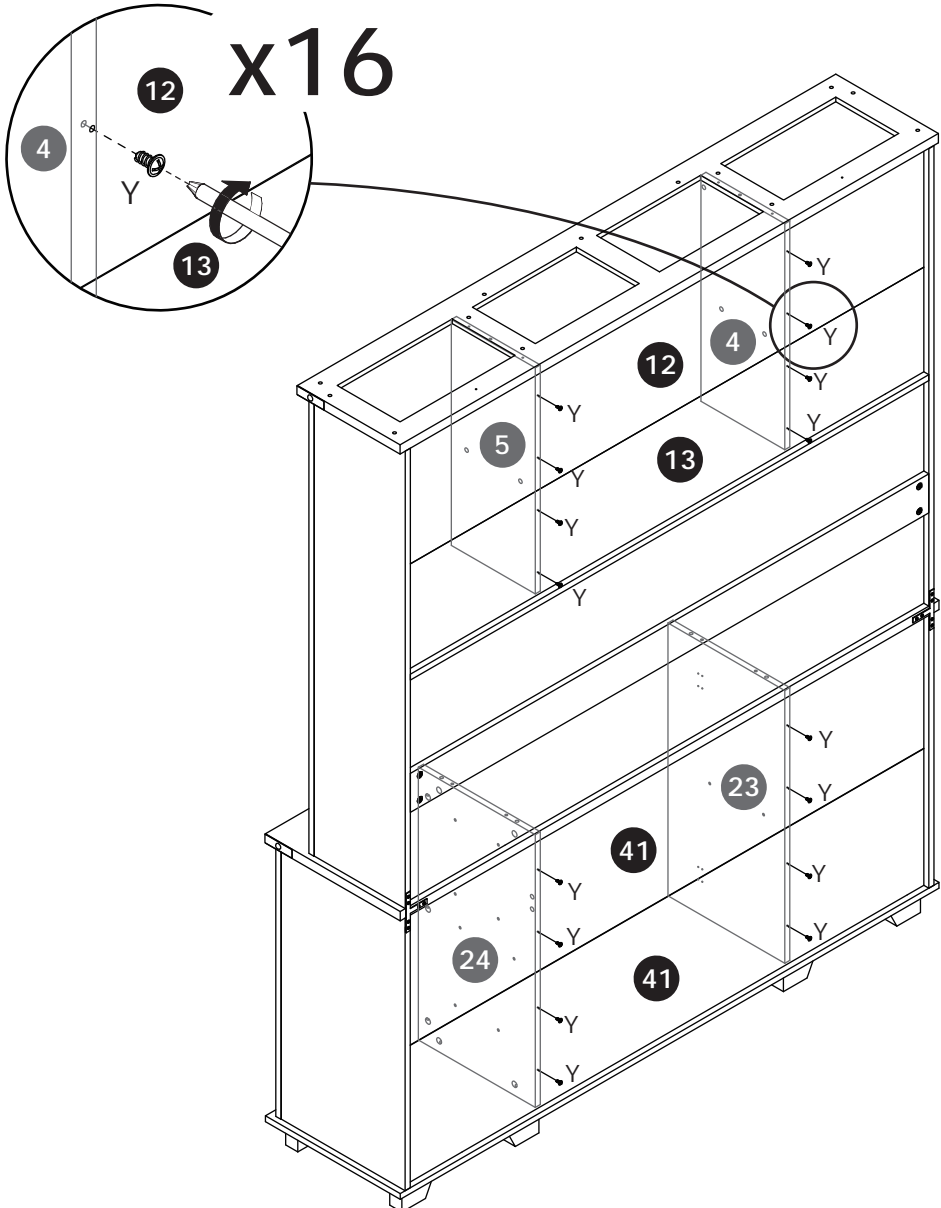

44



[EN] Insert component (W) into the slot and secure it with screw (N).

[ES] Inserte el componente (W) en la ranura y fíjelo con el tornillo (N).

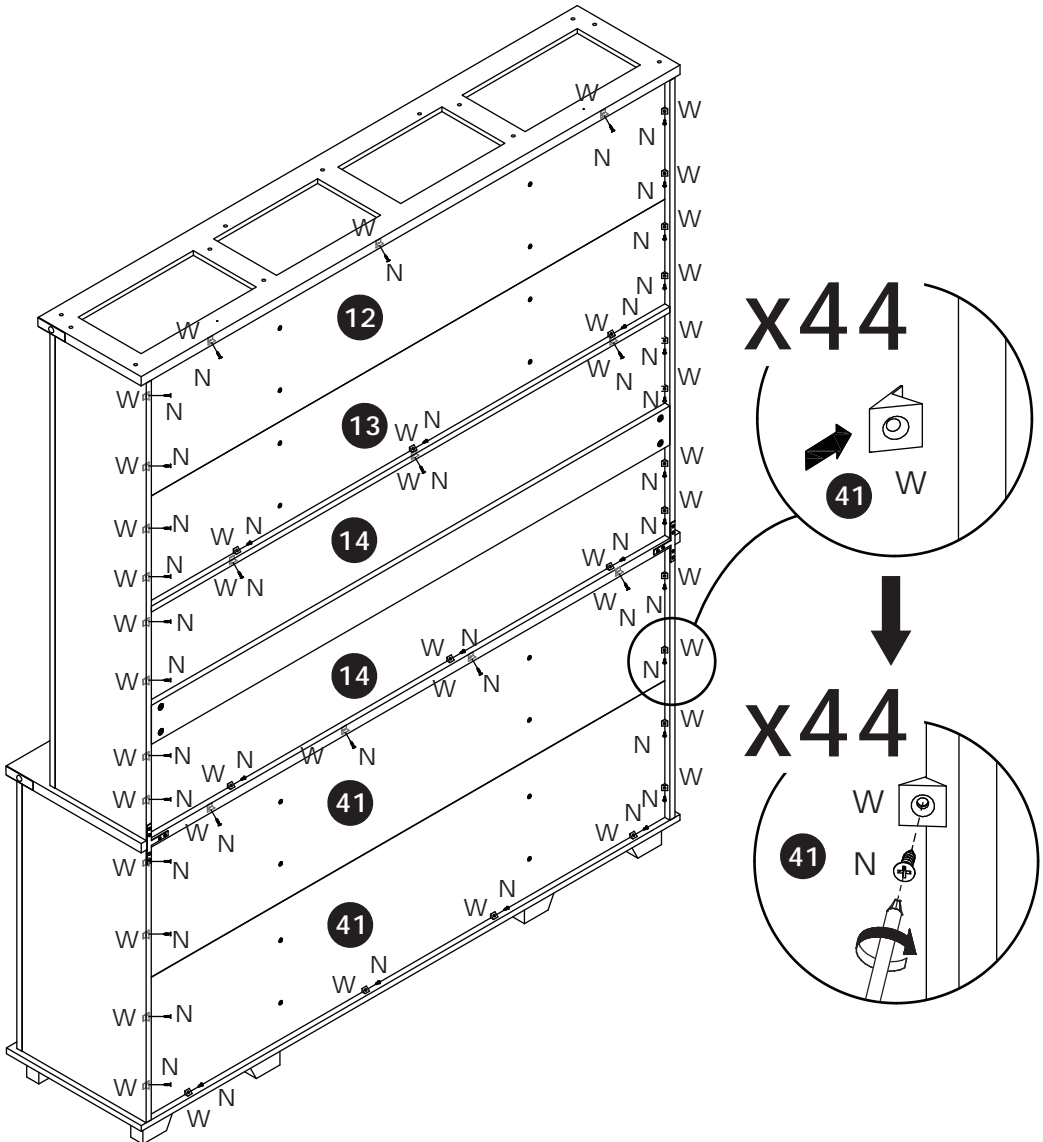

45

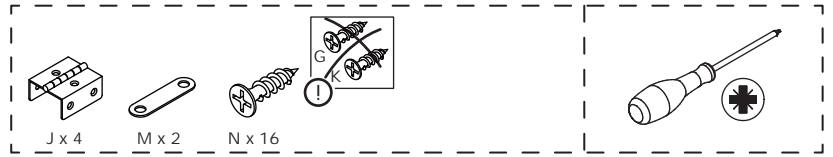

[EN] Secure hinge (J) and component (M) to panels 18 and 19 with screws (N).

[ES] Fije la bisagra (J) y el componente (M) a los paneles 18 y 19 con tornillos (N).

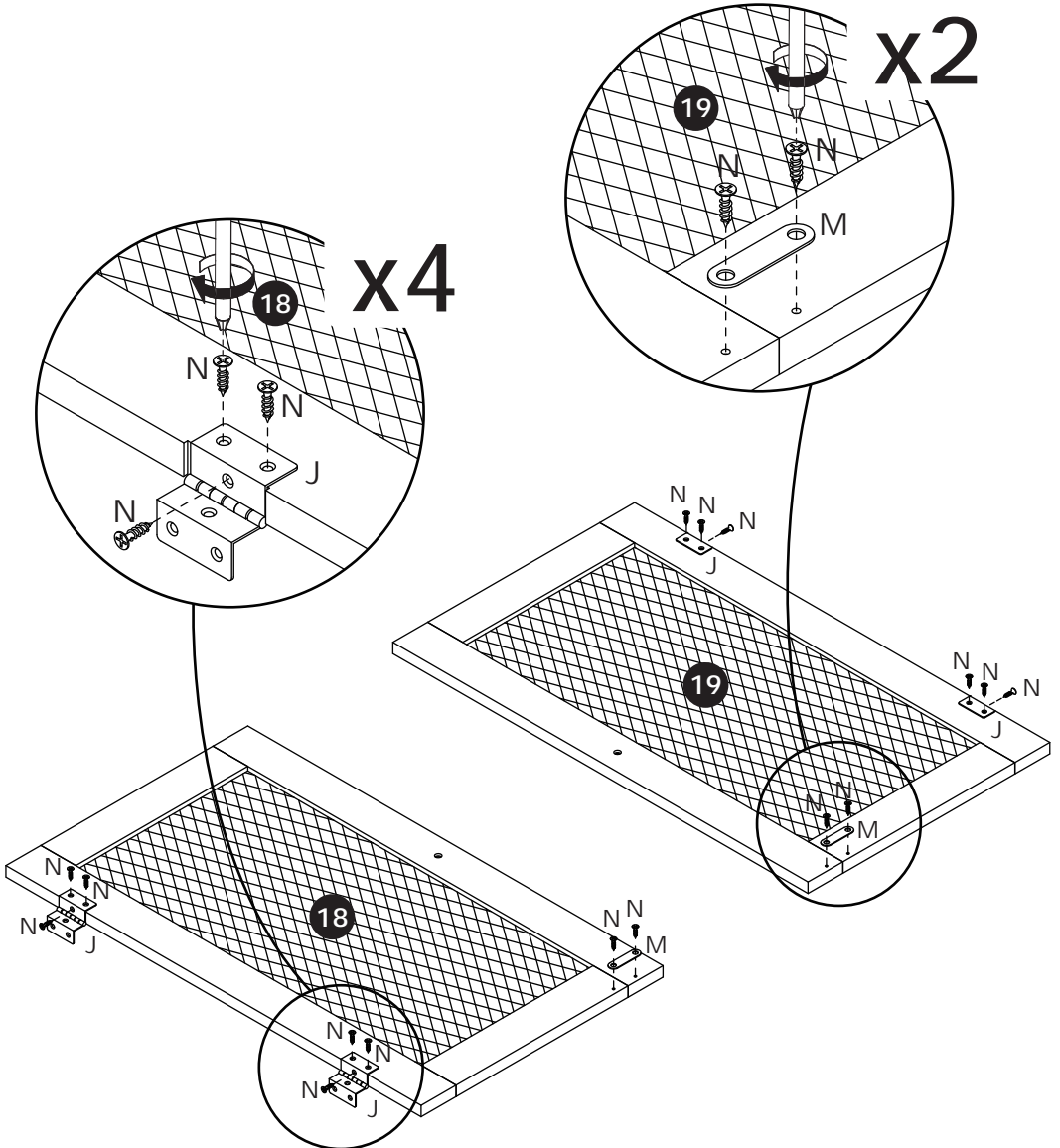

46



[EN] Secure panels 18 and 19 to panels 2 and 3 with hinges using screws (N).

[ES] Fije los paneles 18 y 19 a los paneles 2 y 3 con las bisagras usando tornillos (N).

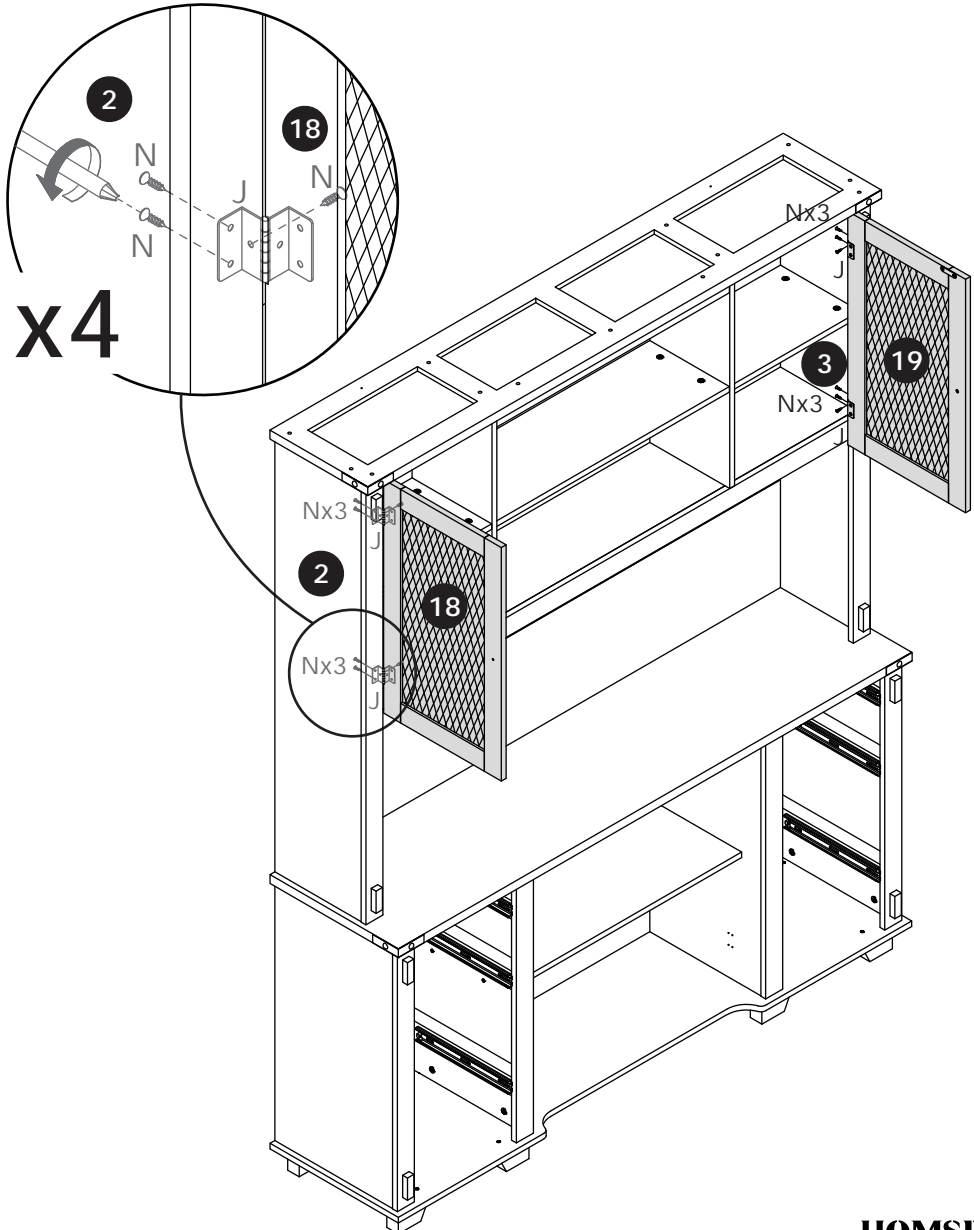

47

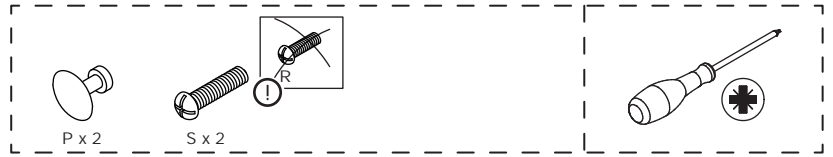

[EN] Secure knob (P) to panels 18 and 19 with screws (S).

[ES] Fije la perilla (P) a los paneles 18 y 19 con tornillos (S).

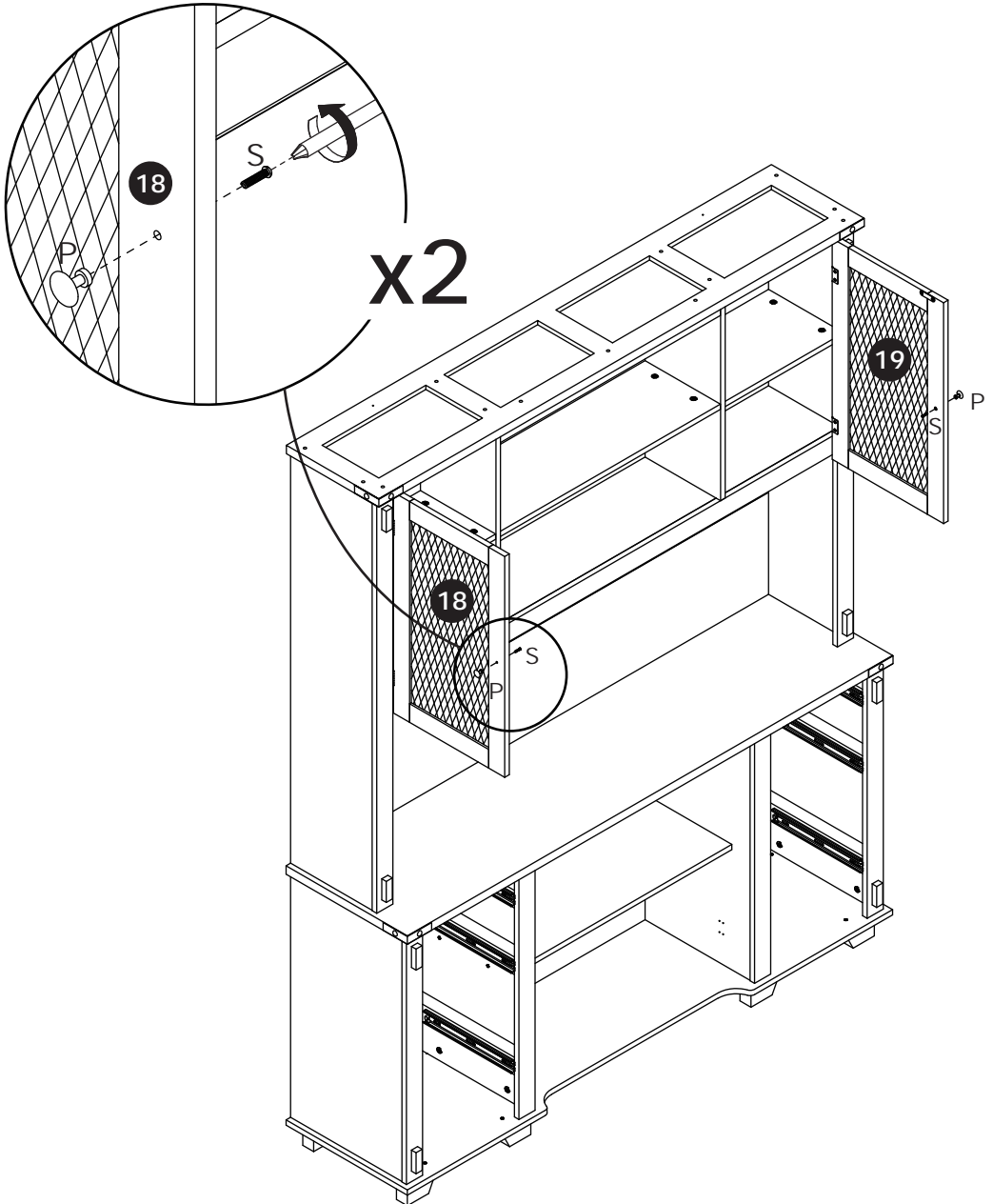

48



[EN] Secure hinge (H) to panel 45 with screws (K).

[ES] Fije la bisagra (H) al panel 45 con tornillos (K).

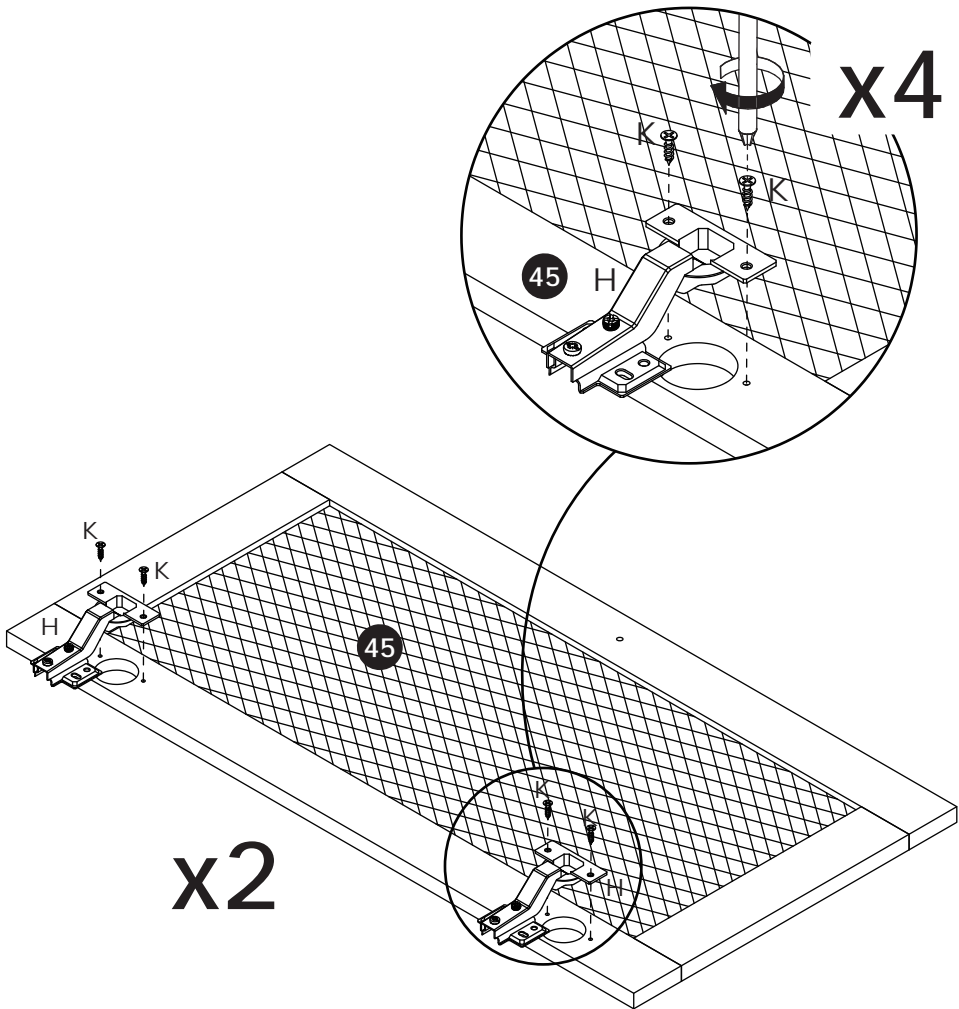

49



[EN] Secure panel 45 to panels 23 and 24 with hinges using screws (K).

[ES] Fije el panel 45 a los paneles 23 y 24 con las bisagras usando tornillos (K).

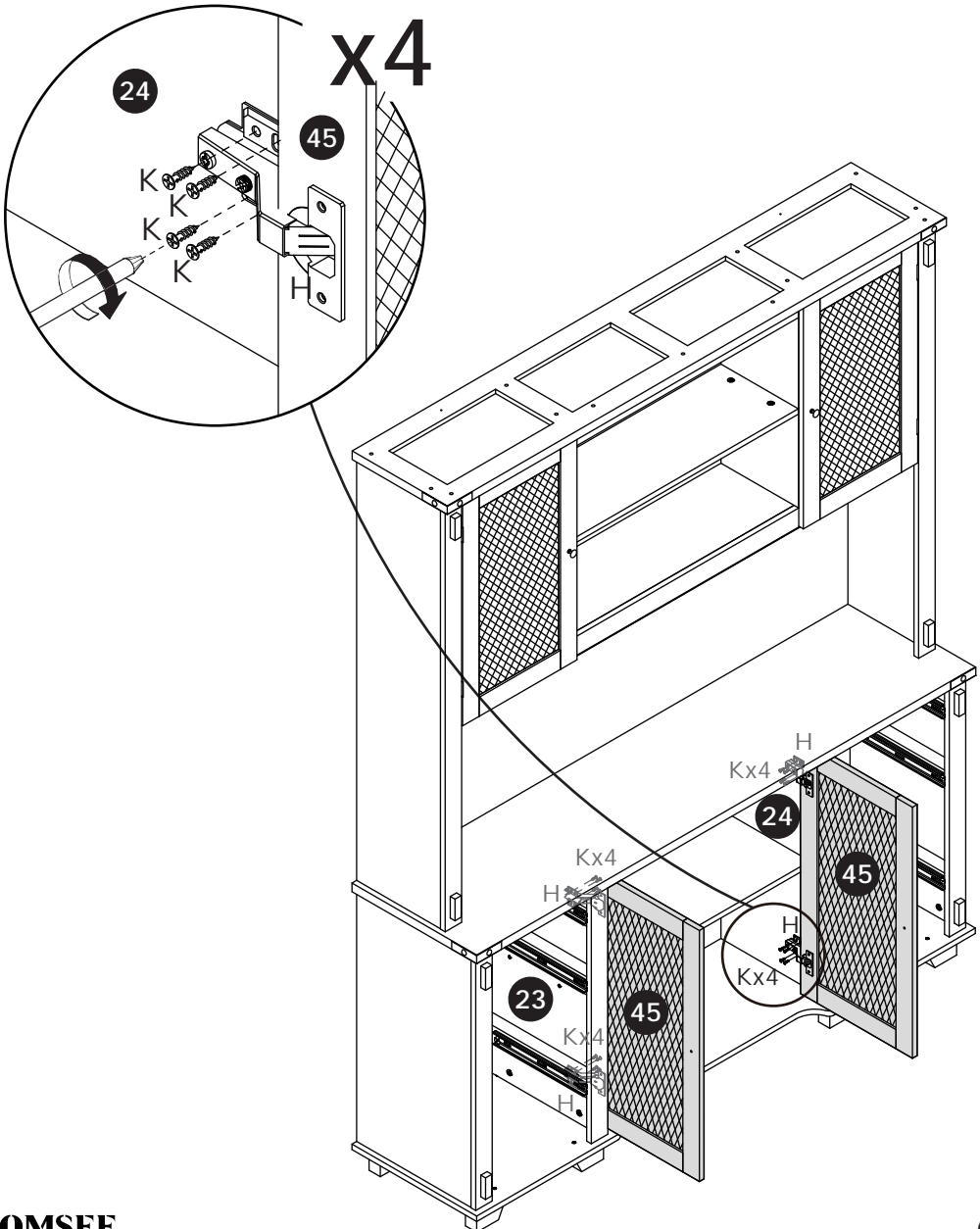

50

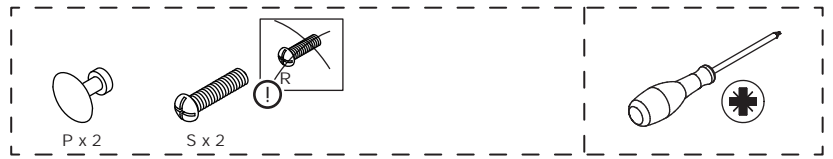

[EN] Secure knob (P) to panel 45 with screws (S).

[ES] Fije la perilla (P) al panel 45 con tornillos (S).

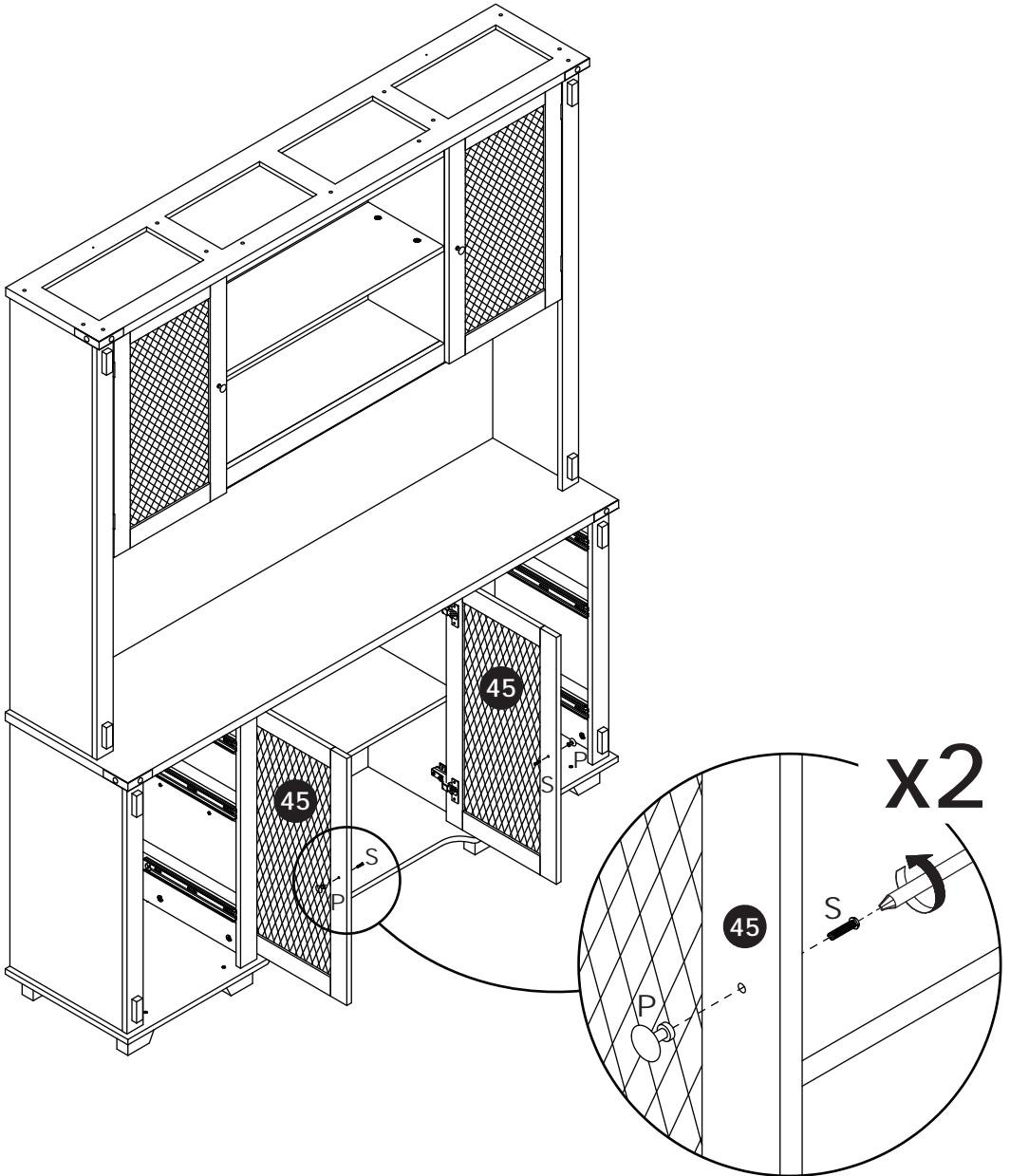

51



[EN] Secure bracket (T) to panel 1 with screws (K).

[ES] Fije el soporte (T) al panel 1 con tornillos (K).

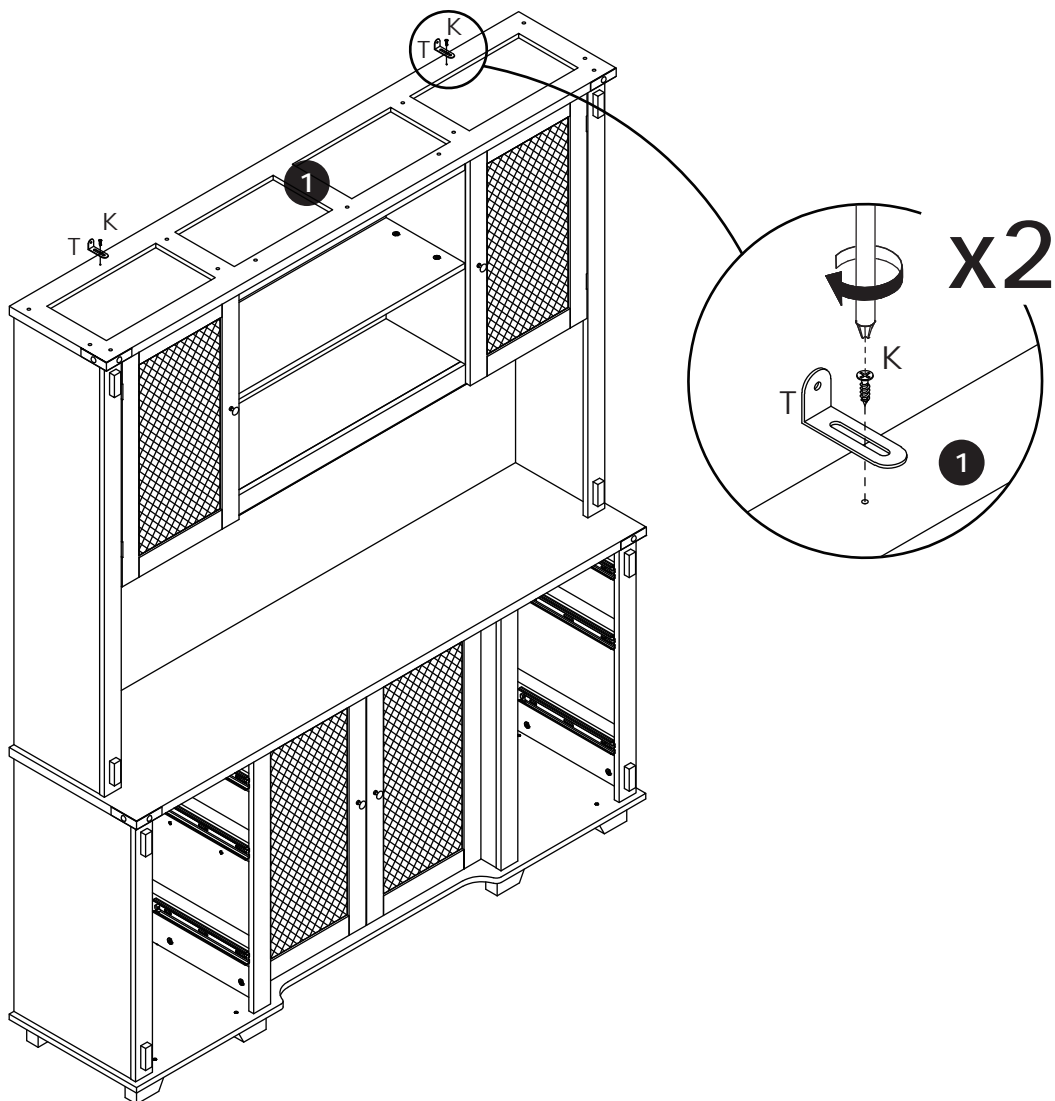

52

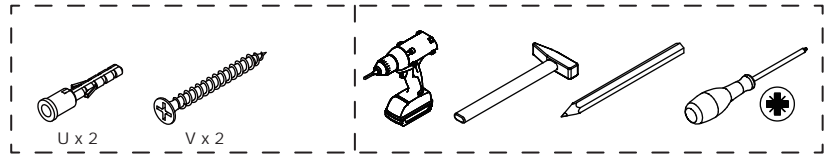

[EN] As shown, install the anti-tip device.

[ES] Como se muestra, instale el dispositivo antivuelco.

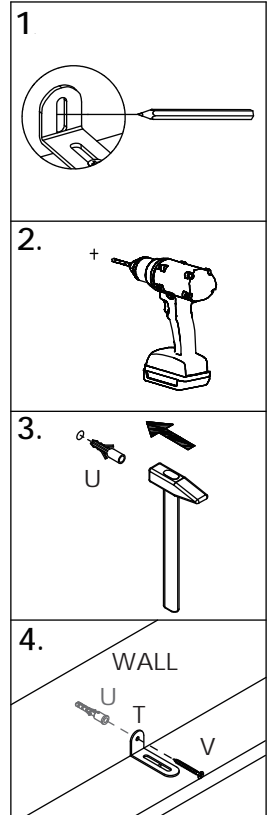
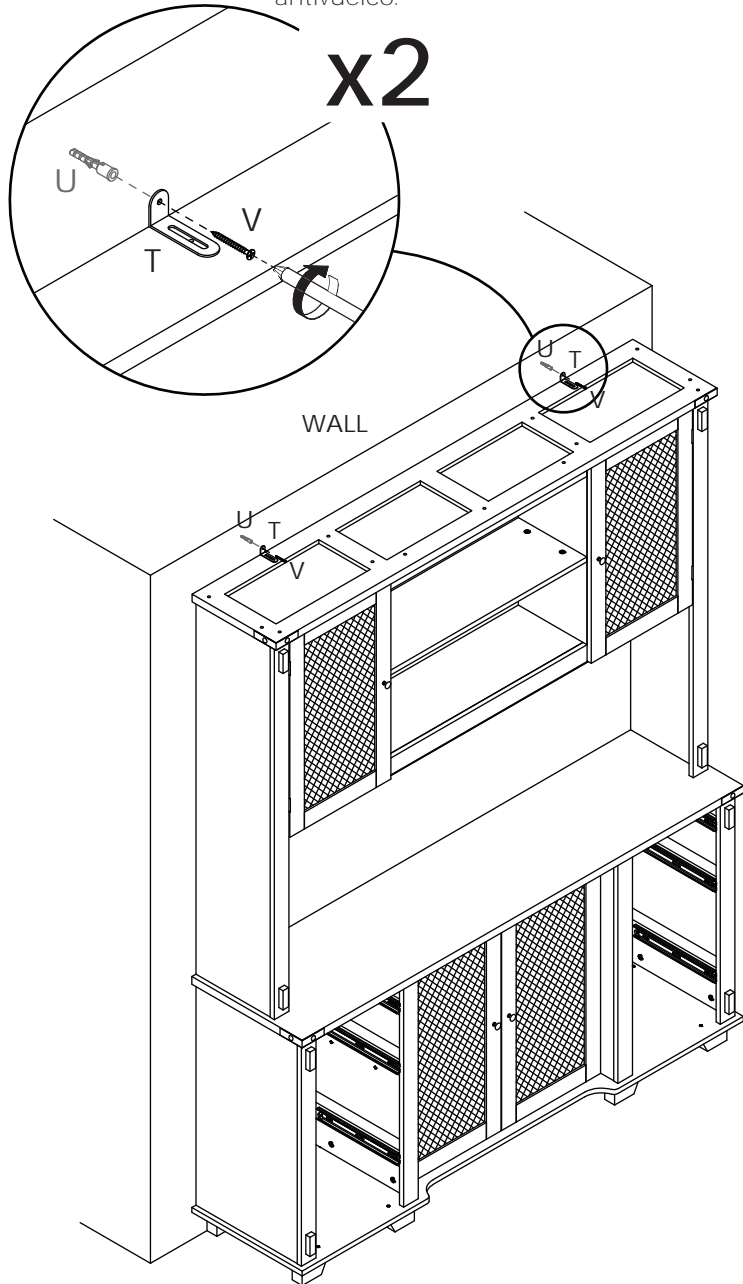

53



[EN] Install component (C) onto panels 27, 31, and 35, and screw the self-tapping rod (B) into panels 27, 31, and 35.

[ES] Coloque el componente (C) en los paneles 27, 31 y 35, y atornille la varilla autorroscante (B) en los paneles 27, 31 y 35.

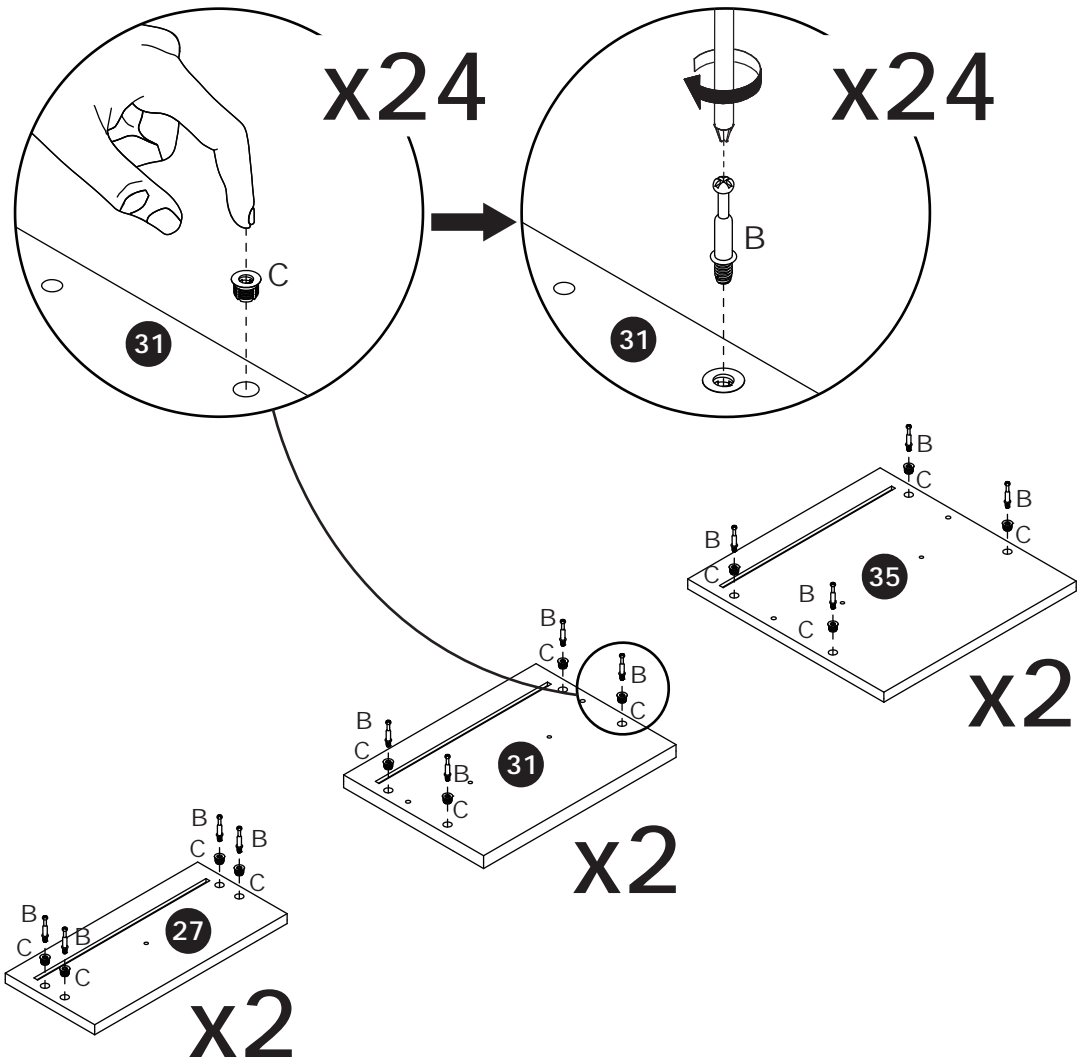

54



[EN] Use wooden dowels (D) to connect panels 28 and 29 to panel 27, then secure with eccentric cams (A). Use the same method to connect panels 32 and 33 to panel 31, and panels 36 and 37 to panel 35.

[ES] Use clavijas de madera (D) para conectar los paneles 28 y 29 al panel 27, y asegure con levas excéntricas (A). Use el mismo método para conectar los paneles 32 y 33 al panel 31, y los paneles 36 y 37 al panel 35.

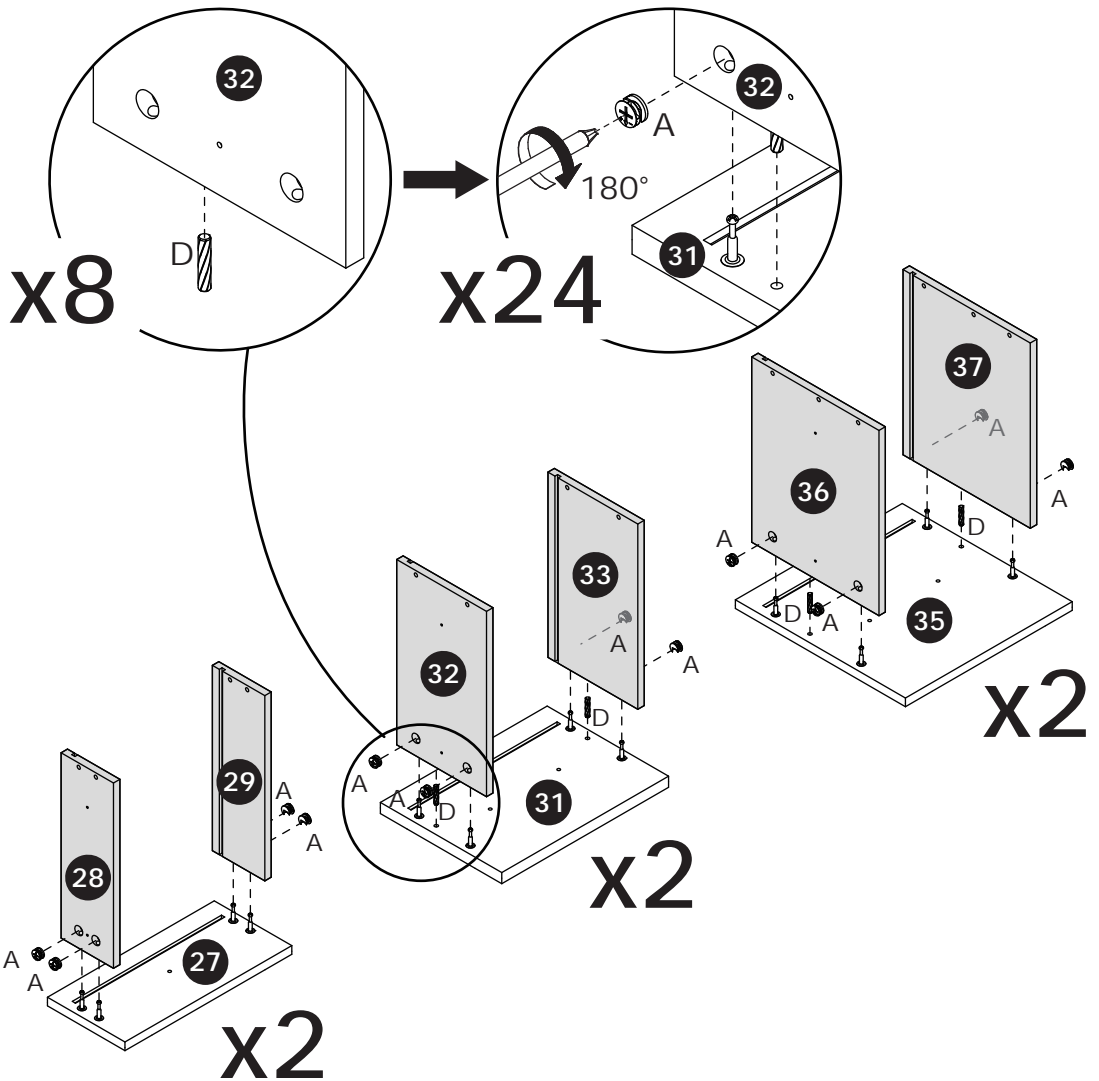

55

[EN] Insert panel 39 into the slot.

[ES] Inserte el panel 39 en la ranura.

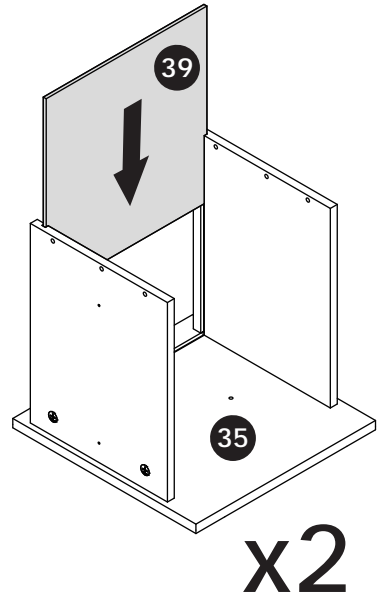
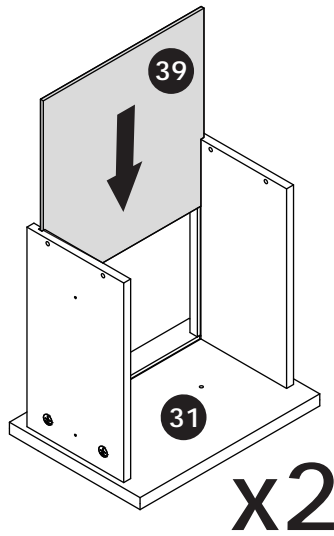
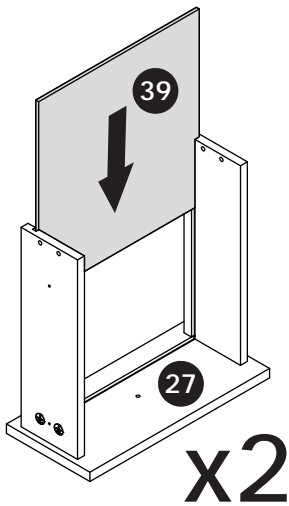

56



[EN] Secure panel 30 to panels 28 and 29, panel 34 to panels 32 and 33, and panel 38 to panels 36 and 37 with screws (E).

[ES] Fije el panel 30 a los paneles 28 y 29, el panel 34 a los paneles 32 y 33, y el panel 38 a los paneles 36 y 37 con tornillos (E).

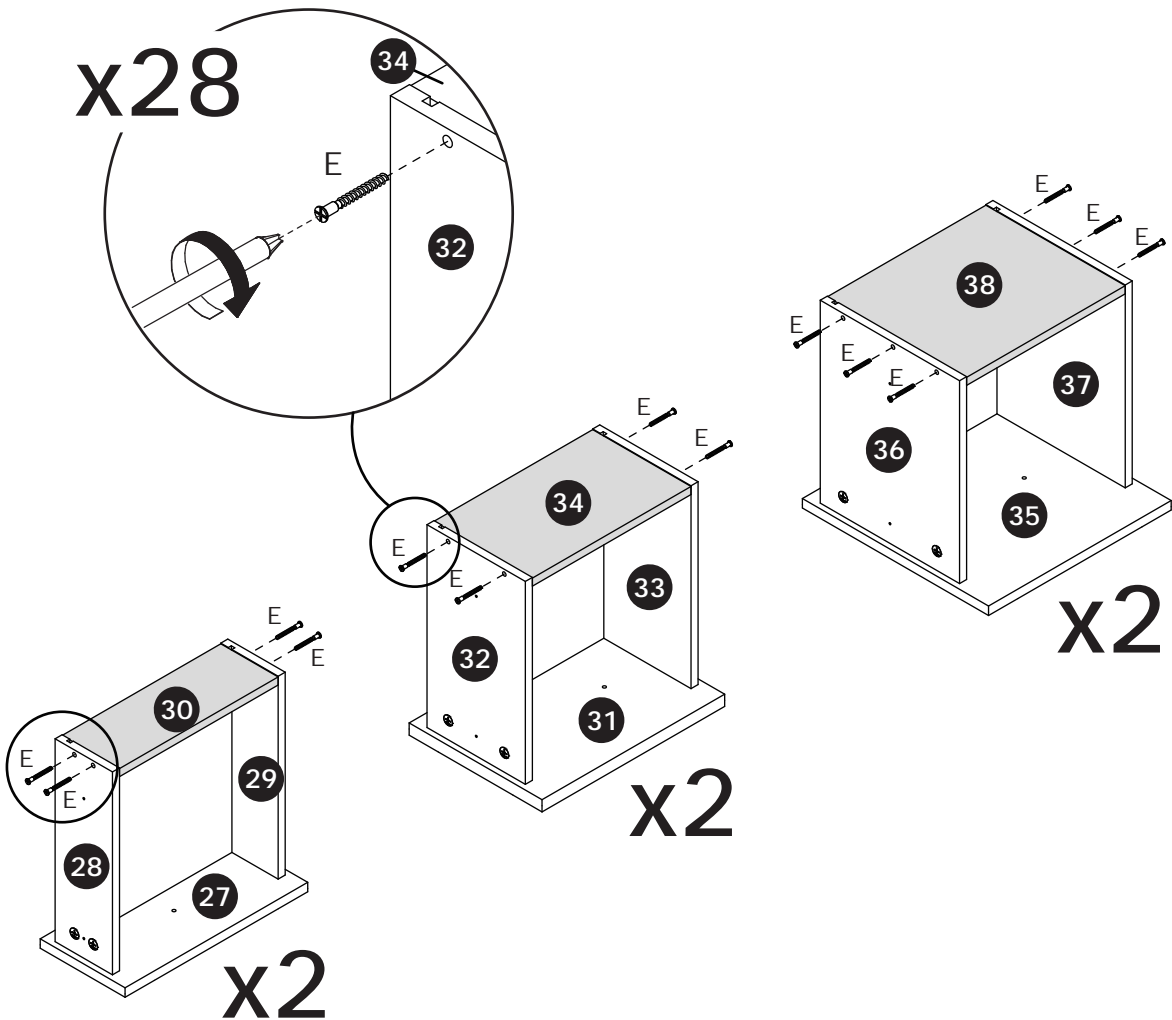

57

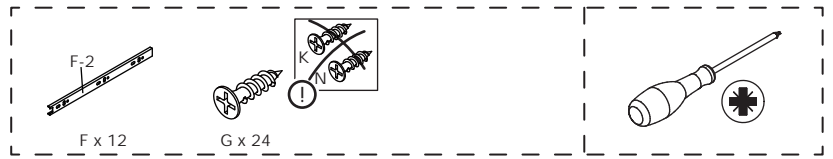

[EN] Secure slide rail (F-2) to panels 28, 29, 32, 33, 36, and 37 with screws (G).

[ES] Fije el riel deslizante (F-2) a los paneles 28, 29, 32, 33, 36 y 37 con tornillos (G).

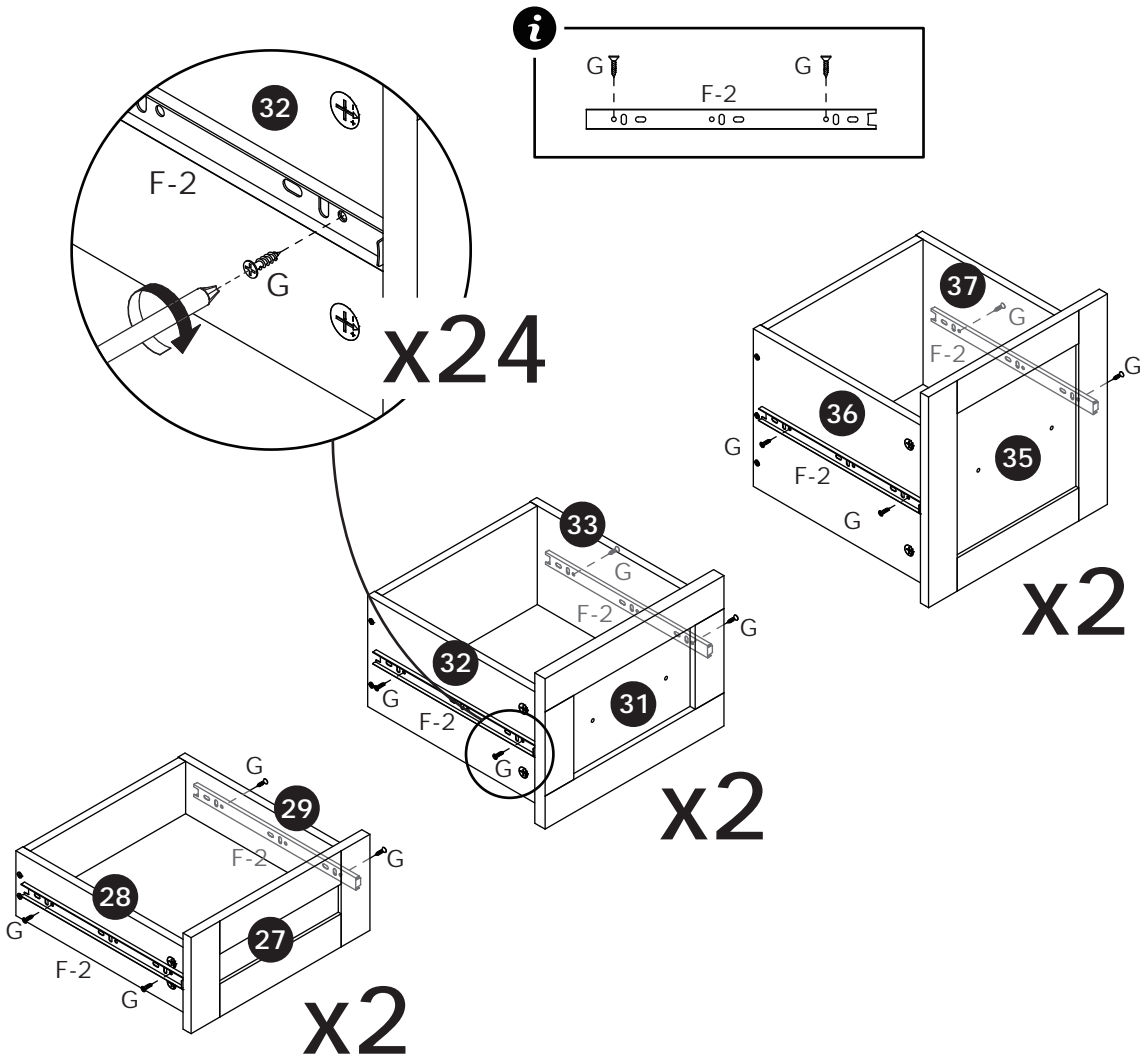

58

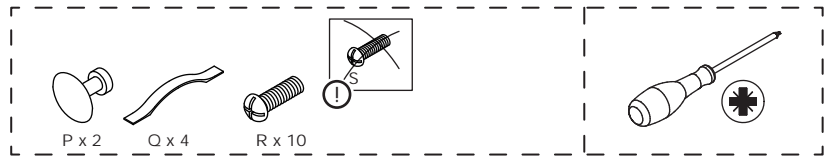

[EN] Secure knob (P) to panel 27 with screw (S), and secure handle (O) to panels 31 and 35 with screw (R).

[ES] Fije la perilla (P) al panel 27 con el tornillo (S), y fije la manija (O) a los paneles 31 y 35 con el tornillo (R).

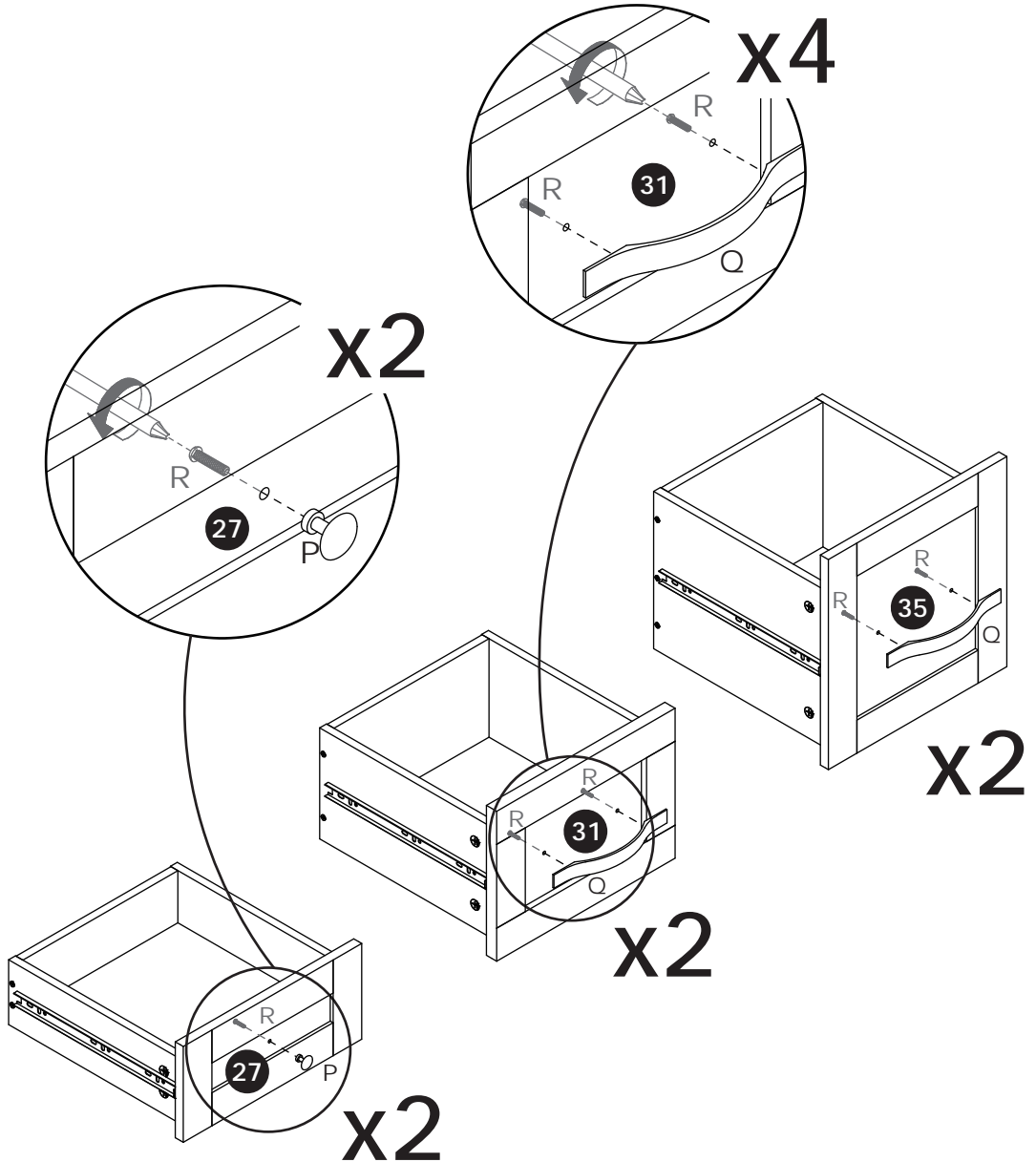

59

[EN] Make sure the slide rails are properly aligned before pushing in the drawers. Misalignment may cause the steel balls in the slide rails to fall out.

[ES] Asegúrese de que los rieles deslizantes estén correctamente alineados antes de empujar los cajones. Una desalineación puede provocar que las bolas de acero del riel se salgan.

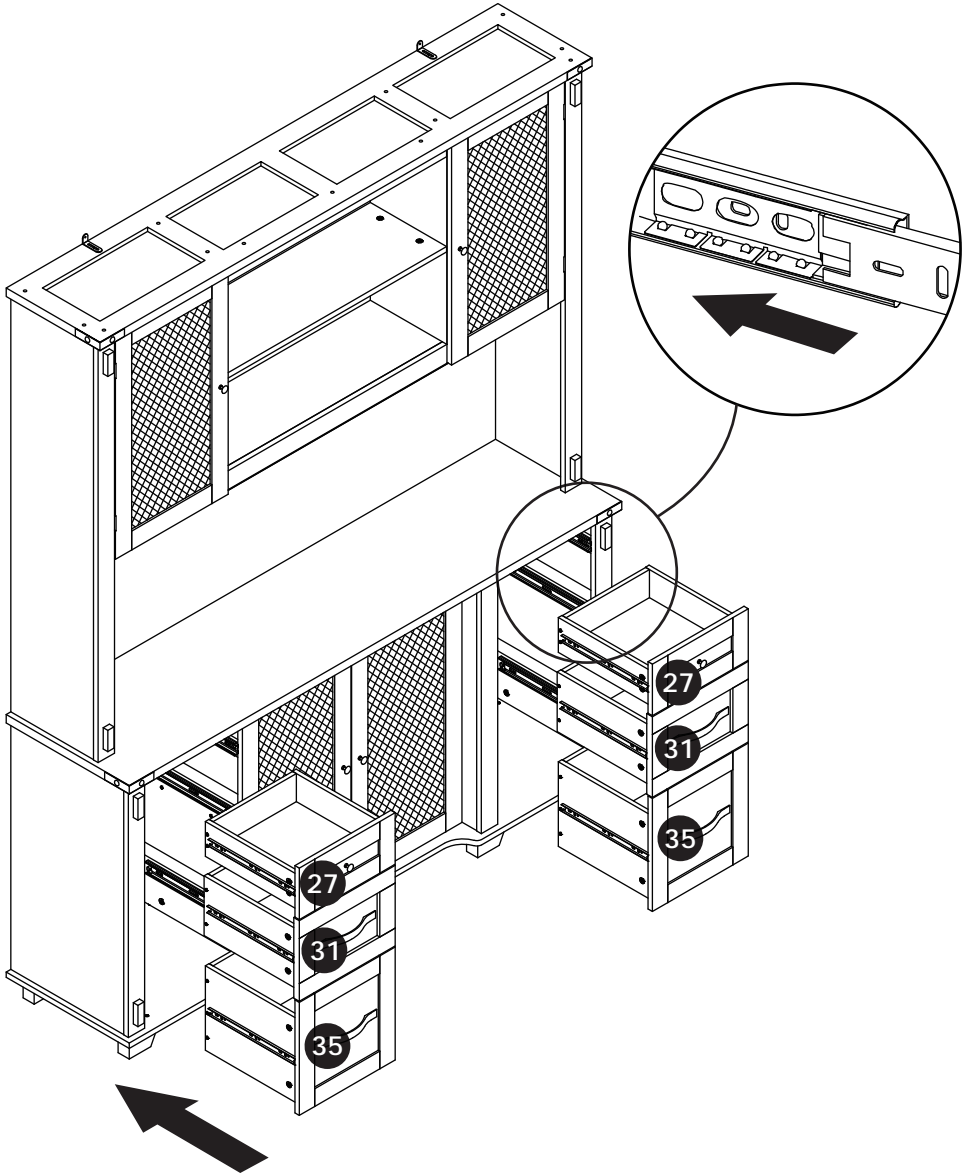

60



[EN] If the doors are not aligned after installation, watch the video.
Adjust the hinge screws as needed to achieve proper alignment.

[ES] Si las puertas no están alineadas después de la instalación, vea el video.
Ajuste los tornillos de las bisagras según sea necesario para lograr una alineación correcta.

<https://youtu.be/n0Lb36SoODM>

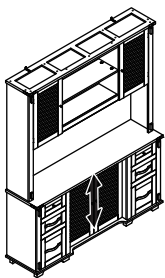
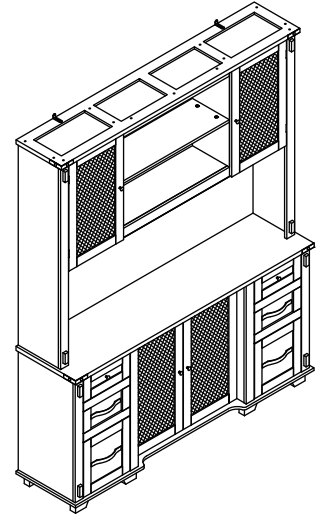

Ⓘ

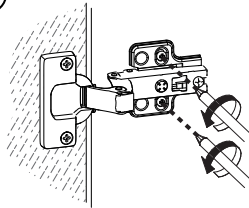

Ⓜ

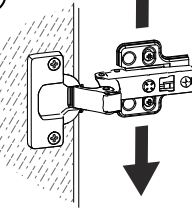

ⓓ

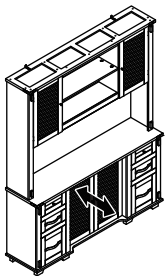
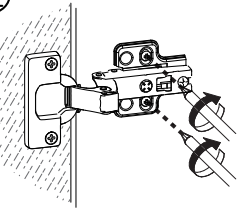

Ⓘ

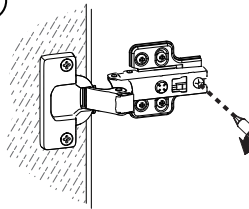

Ⓜ

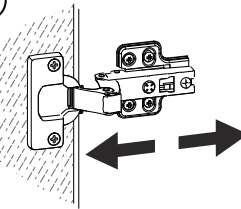

ⓓ

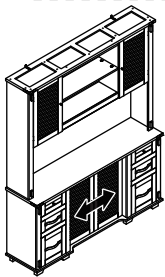
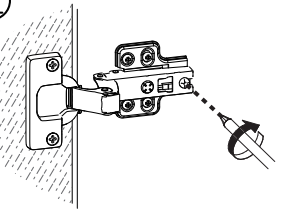

Ⓘ

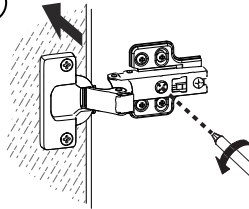

Ⓜ

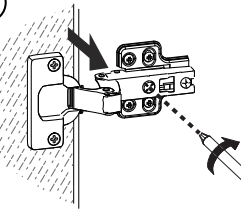

Should you have any problems assembling your product, contact us at customerservice@homsee.com. We're always happy to help! We have carefully selected the materials used in this product, and ask you to treat it responsibly too. Please recycle all packaging according to your local disposal rules.

Si tienes algún problema al ensamblar tu producto, contáctanos a customerservice@homsee.com. Siempre estaremos encantados de ayudarte. Hemos seleccionado cuidadosamente los materiales utilizados en este producto y te pedimos que también lo trates de manera responsable. Por favor, recicla todo el embalaje de acuerdo con las normas locales de eliminación de residuos.

